

ENTERED

F 2302

# San Francisco Law Library

436 CITY HALL

No. 162083

## EXTRACT FROM RULES

Rule 1a. Books and other legal material may be borrowed from the San Francisco Law Library for use within the City and County of San Francisco, for the periods of time and on the conditions hereinafter provided, by the judges of all courts situated within the City and County, by Municipal, State and Federal officers, and any member of the State Bar in good standing and practicing law in the City and County of San Francisco. Each book or other item so borrowed shall be returned within five days or such shorter period as the Librarian shall require for books of special character, including books constantly in use, or of unusual value. The Librarian may, in his discretion, grant such renewals and extensions of time for the return of books as he may deem proper under the particular circumstances and to the best interests of the Library and its patrons. Books shall not be borrowed or withdrawn from the Library by the general public or by law students except in unusual cases of extenuating circumstances and within the discretion of the Librarian.

Rule 2a. No book or other item shall be removed or withdrawn from the Library by anyone for any purpose without first giving written receipt in such form as shall be prescribed and furnished for the purpose, failure of which shall be ground for suspension or denial of the privilege of the Library.

Rule 5a. No book or other material in the Library shall have the leaves folded down, or be marked, dog-eared, or otherwise soiled, defaced or injured, and any person violating this provision shall be liable for a sum not exceeding treble the cost of replacement of the book or other material so treated and may be denied the further privilege of the Library.







Digitized by the Internet Archive  
in 2010 with funding from  
Public.Resource.Org and Law.Gov



N. 3025

No. 15431

United States  
Court of Appeals  
for the Ninth Circuit

HENRY J. ERNST,

Appellant,

vs.

SECRETARY OF THE INTERIOR, SOLICITOR,  
DEPARTMENT OF THE INTERIOR  
and ROY N. MIKEL,

Appellees.

Transcript of Record

Appeal from the District Court  
for the District of Alaska,  
Fourth Division.

FILE

MAR 29 1957

PAUL P. O'BRIEN, C





No. 15431

---

United States  
Court of Appeals  
for the Ninth Circuit

---

HENRY J. ERNST,

Appellant,

vs.

SECRETARY OF THE INTERIOR, SOLICITOR,  
DEPARTMENT OF THE INTERIOR  
and ROY N. MIKEL,

Appellees.

---

Transcript of Record

---

Appeal from the District Court  
for the District of Alaska,  
Fourth Division.



## INDEX

---

[Clerk's Note: When deemed likely to be of an important nature, errors or doubtful matters appearing in the original certified record are printed literally in italic; and, likewise, cancelled matter appearing in the original certified record is printed and cancelled herein accordingly. When possible, an omission from the text is indicated by printing in italic the two words between which the omission seems to occur.]

	PAGE
Affidavit of Mailing.....	7
Answer .....	10
Appeal Bond .....	16
Attorneys of Record.....	1
Certificate of Clerk.....	18
Complaint .....	3
Memorandum Opinion .....	11
Motion to Quash the Return of Service of Sum- mons and to Dismiss the Complaint.....	9
Notice of Appeal.....	15
Order to Quash the Return of Service of Sum- mons and to Dismiss the Complaint.....	14
Statement of Points.....	17
Summons Filed November 6, 1956.....	5
Return on Service of Writ.....	5
Summons Filed November 8, 1956.....	6
Return on Service of Writ.....	7



ATTORNEYS OF RECORD

MAURICE T. JOHNSON,  
Room 316 Chena Bldg.,  
Fairbanks, Alaska,

Attorney for Plaintiff and Appellant.

GEORGE M. YEAGER,  
U. S. Attorney,  
P. O. Box 111,  
Fairbanks, Alaska,

Attorney for Defendants, Secretary of  
the Interior and Solicitor, Dept. of  
Interior, Appellee.

EUGENE V. MILLER,  
527 Fourth Ave.,

Attorney for Defendant Roy N. Mikel, Ap-  
pellee.



In the District Court for the District of Alaska,  
Fourth Division  
No. 9303

HENRY J. ERNST,

Plaintiff,

vs.

SECRETARY OF THE INTERIOR, SOLICITOR,  
DEPARTMENT OF THE INTERIOR,  
ROY N. MIKEL,

Defendants.

COMPLAINT TO REVIEW DECISION OF  
SECRETARY OF THE INTERIOR

Now Comes the Plaintiff above named, and for cause of action against the Defendants, complains and alleges, as follows:

I.

Jurisdiction is conferred upon this Court by Title 5, U.S.C.A., Section 1009, that on or about the 7th day of November, 1955, a decision of the acting Director of the Bureau of Land Management was awarded by the Solicitor of the Department of the Interior by and through the Secretary of the Interior, Fairbanks Entry No. 08294. This decision cancelled the Homestead Entry of the Plaintiff and permitted the re-entry by the Defendant, Roy N. Mikel who was the Contestant.

II.

The Plaintiff's original Entry was allowed on August 28, 1951; that the Defendant Roy N. Mikel instituted contest proceedings on August 28, 1952; that during the Summer of 1952 there had been a great deal of rain in the area and the particular

Homestead in question was low and unfilled and as a result was very marshy. That it was difficult to do anything in the way of actual building on the property during that Summer; that the Plaintiff cleared six acres of land, procured gravel for a ramp from the highway to the Homestead building site, drilled a water well on the premises and sunk six concrete piers for footings for the house foundation, and did everything that could be done under the circumstances to establish an actual personal residence.

### III.

The Plaintiff desires a review of the entire contest of his entry and requests a hearing before this Court to establish the rights of the Plaintiff in the property for the reason that the decision of the Secretary of the Interior is erroneous and illegal, arbitrary and capricious, and therefore should be set aside.

Wherefore, the Plaintiff prays that the decision of the Secretary of the Interior in Fairbanks No. 08294 decided November 7, 1955, be reviewed in its entirety, and that the said Decision be set aside and declared null and void, and that the original Entry of the Plaintiff be reinstated; and for such other relief as to the Court may seem just in the premises.

/s/ HENRY J. ERNST,  
Plaintiff.

/s/ MAURICE T. JOHNSON,  
Attorney for Plaintiff.

Duly verified.

[Endorsed]: Filed November 5, 1956.



[Title of District Court and Cause.]

SUMMONS

To the above-named Defendant:

You are hereby summoned and required to serve upon Maurice T. Johnson, plaintiff's attorney, whose address is Room 316 Chena Building, Fairbanks, Alaska, and answer to the complaint which is herewith served upon you, within sixty days after service of this summons upon you, exclusive of the day of service. If you fail to do so, judgment by default will be taken against you for the relief demanded in the complaint.

Date: Nov. 5, 1956.

[Seal]     /s/ JOHN B. HALL,  
  Clerk of Court.

           /s/ OLGA T. STEGER,  
  Chief Deputy Clerk.

Return on Service

United States of America,  
4th District of Alaska—ss.

I hereby certify and return that I served the annexed Summons & Complaint on the therein-named Secretary of the Interior Solicitor, Department of the Interior, by handing to and leaving a true and correct copy thereof with U. S. District Attorney, George M. Yeager, personally at Attorney's

Office, Federal Bldg., at Fairbanks, Alaska, in the said District at 9:15 a.m., on the 6th day of November, 1956.

Marshal's fees \$3.00.

A. F. DORSH,  
United States Marshal.

By /s/ ELFRIEDA C. FRANCK,  
Deputy.

[Endorsed]: Filed November 6, 1956.

---

[Title of District Court and Cause.]

### SUMMONS

To the aboved-named Defendant:

You are hereby summoned and required to serve upon Maurice T. Johnson, plaintiff's attorney, whose address Room 316 Chena Building, Fairbanks, Alaska, an answer to the complaint which is herewith served upon you, within twenty days after service of this summons upon you, exclusive of the day of service. If you fail to do so, judgment by default will be taken against you for the relief demanded in the complaint.

Date: Nov. 5, 1956.

[Seal] JOHN B. HALL,  
Clerk of Court.

/s/ OLGA T. STEGER,  
Chief Deputy Clerk.

Return of Service

United States of America,  
4th District of Alaska—ss.

I hereby certify and return that I served the annexed Summons & Complaint on the therein-named Roy N. Mikel, by handing to and leaving a true and correct copy thereof with Roy N. Mikel personally, at Residence, Garrison Fast Freight Road, at Fairbanks Precinct, Alaska, in the said District at 11:05 a.m., on the 7th day of November, 1956.

Marshal's fees \$3.00.

Mileage \$1.20.

A. F. DORSH,  
United States Marshal.

By /s/ ELWYN M. ROBINSON,  
Deputy.

[Endorsed]: Filed November 8, 1956.

---

[Title of District Court and Cause.]

AFFIDAVIT OF MAILING

United States of America,  
Territory of Alaska,  
Fourth Judicial Division—ss.

Reta M. Walker, being first duly sworn, on oath deposes and says: That she is employed in the office of Maurice T. Johnson, attorney for the Plaintiff. That on the 6th day of November, 1956, she placed

in the United States mail at the Post Office in Fairbanks, Alaska, an envelope addressed to each of the following:

Attorney General of the United States,  
Department of Justice,  
Washington, D. C.;

Secretary of the Interior,  
Department of the Interior,  
Washington, D. C.

Solicitor,  
Department of the Interior,  
Washington, D. C.

Each said envelope contained a copy of the Complaint to Review Decision of Secretary of the Interior, and the Summons, and carried the requisite amount of postage to insure delivery by registered air mail, return receipt requested.

Further this affiant sayeth not.

/s/ RETA M. WALKER.

Subscribed and sworn to before me this 8th day of November, 1956.

[Seal] /s/ MAURICE T. JOHNSON,  
Notary Public in and for  
Alaska.

My commission expires 4/17/60.

[Endorsed]: Filed November 28, 1956.

[Title of District Court and Cause.]

MOTION TO QUASH THE RETURN OF SERVICE OF SUMMONS AND TO DISMISS THE COMPLAINT

Comes now the Secretary of the Department of Interior and the Solicitor of the Department of the Interior by and through George M. Yeager, United States Attorney for the Fourth Judicial Division, District of Alaska, and moves this honorable Court for an order quashing the return of service of summons and for an order dismissing the complaint for the reason that these government officials are residents of the District of Columbia and personal actions against these two defendants can only be brought against them in the district of their official domicile. Thus this Court does not have venue as to these two defendants.

Dated at Fairbanks, Alaska, this 27th day of November, 1956.

/s/ GEORGE M. YEAGER,  
United States Attorney.

Receipt of Copy acknowledged.

[Endorsed]: Filed November 28, 1956.

[Title of District Court and Cause.]

ANSWER

Comes Now Roy N. Mikel, one of the above-named defendants and for his answer admits, denies and alleges as follows:

I.

Denies that jurisdiction is conferred upon this Court by Title 5, but admits that a decision in favor of the contestant was entered.

II.

Not having sufficient information upon which to base a belief, denies the allegations contained in paragraph II.

III.

Denies each and every allegation contained in paragraph III.

Wherefore, the defendant having answered the allegations of the plaintiff, prays that the court dismiss the action and that the plaintiff take nothing thereby as well as that the plaintiff be ordered to pay the defendant's attorney fees and costs incurred herein.

/s/ EUGENE V. MILLER.

Duly verified.

Receipt of Copy acknowledged.

[Endorsed]: Filed December 11, 1956.

[Title of District Court and Cause.]

### MEMORANDUM OPINION

Plaintiff in this action seeks a review by this court of a decision of the Secretary of the Interior, acting through the Director of the Bureau of Land Management and the Solicitor of the Department of the Interior, canceling a homestead entry made by him and permitting the re-entry by the defendant Roy N. Mikel, contestant; and praying that said decision be set aside and declared null and void, and that the original entry of the plaintiff be reinstated.

Service of summons and complaint upon the Secretary of the Interior and the Solicitor of the Department of the Interior was made upon the United States Attorney for this District, and copies thereof sent by registered mail to such officials and to the Attorney General of the United States at their official residences in Washington, D.C. Summons and complaint was served upon the defendant Mikel in this District.

The Secretary of the Interior and the Solicitor of the Department of the Interior have appeared specially by the United States Attorney and moved the court for an order quashing the return of service of summons and dismissing the complaint, upon the grounds that these Government officials are residents of the District of Columbia and such action can be brought against them only in the district of their official residence.

Jurisdiction to review such decision could only be conferred by the provisions of Sec. 10 of the Administrative Procedure Act, Title 5, Sec. 1009, U.S.C., upon which plaintiff relies. This statute provides for judicial review of "agency action" of any administrative authority or agency of the United States, which proceeding, in the absence of any specific statute, may be brought "in any court of competent jurisdiction." It is well settled that any action under the provisions of this Act against a public official of the United States in his official capacity can only be maintained at the official residence of such official, within the meaning of Title 28, Sec. 1391, U.S.C.A. *Blackmar vs. Guerre*, 342 U. S. 512, 516; *Trueman Fertilizer Co. vs. Larson* (CCA 5), 196 F. 2d 910; *Nesbitt Fruit Products, Inc. vs. Wallace*, 17 F. Supp. 141; *Torres vs. McGranery*, 111 F. Supp. 241; *Muerer vs. Ryder*, 137 F. Supp. 362; *Clement Martin vs. Dick Corp.*, 97 F. Supp. 961.

Compare *Wilson vs. United States Civil Service Commission*, 136 F. Supp. 104, and *Kansas City Power and Light Co. vs. McKay*, 225 F. 2d 924, where actions to review agency decisions were properly brought in the U. S. District Court for the District of Columbia. In the *Kansas City Power* case the court expressly holds that the Administrative Procedure Act does not of itself establish the jurisdiction of the Federal Courts over an action not otherwise cognizable by them, or does not render competent a court which lacks jurisdiction upon any other ground (p. 933).



As the official residence of the Secretary of the Interior and the Solicitor of the Department of the Interior was and is in the District of Columbia this action cannot be maintained against them in this District. See cases above cited, and Anno. Title 28, Sec. 1391, U.S.C.A., note 49.

Plaintiff cites as authority for this proceeding *Patton vs. Administrator of Civil Aeronautics, et al.* (CCA 9), 217 F. 2d 395, and *May Department Stores vs. Brown*, 60 F. Supp. 735. In both of these cases general appearances were made by the official involved and the question of venue did not arise. Plaintiff also cites other decisions of the Federal courts to the effect that the courts have the power to review administrative discretion or to compel a correction or remedy abuse of discretion, but none of the cases cited involve a review of administrative action as such and in none of these cases is the question of venue raised.

The court does have jurisdiction over the defendant Mikel, who has appeared by answer denying jurisdiction conferred upon this court by Sec. 1009, Title 5. This does not aid the plaintiff for the reason that no relief can possibly be granted against this defendant in these proceedings and that the Secretary and the Solicitor of the Department of the Interior are indispensable parties, and the courts of the District of Columbia are the only courts of "competent jurisdiction" to entertain such suit against them. *Blackmar vs. Guerre, supra*; *Muerer vs. Ryder, supra*.

The motion is granted, and an order lodged by the United States Attorney quashing the return of service of summons upon the officials mentioned and dismissing the complaint and said action is entered accordingly, which order will be without prejudice to the right of the plaintiff to bring such action in the proper forum.

Dated at Fairbanks, Alaska, this 28th day of December, 1956.

/s/ WALTER H. HODGE,  
District Judge.

[Endorsed]: Filed December 28, 1956.

---

[Title of District Court and Cause.]

ORDER TO QUASH THE RETURN OF SERVICE OF SUMMONS AND TO DISMISS THE COMPLAINT

This matter coming on regularly for hearing this 7th day of December, 1956, upon the motion of George M. Yeager, United States Attorney, for an order to quash the return of service of summons and to dismiss the complaint for the reason that these government officials are residents of the District of Columbia and personal actions against these two defendants can only be brought against them in the district of their official domicile; and the Court being fully advised in the matter,

Now, Therefore, It Is Ordered that the return of service of summons is hereby quashed, and the com-

plaint in this matter is hereby dismissed, and said cause of action is dismissed.

Done at Fairbanks, Alaska, this 28th day of December, 1956.

/s/ WALTER H. HODGE,  
District Judge.

Receipt of Copy acknowledged.

[Endorsed]: Filed December 28, 1956.

Entered December 28, 1956.

---

[Title of District Court and Cause.]

#### NOTICE OF APPEAL

Notice Is Hereby Given that the Plaintiff above named hereby appears to the United States Court of Appeals for the Ninth Circuit from the Order quashing the return of service of summons and dismissing the action entered in the above-entitled case on the 28th day of December, 1956.

Dated at Fairbanks, Alaska, this 25th day of January, 1957.

/s/ MAURICE T. JOHNSON,  
Attorney for Appellant.

Receipt of Copy acknowledged.

[Endorsed]: Filed January 25, 1957.

[Title of District Court and Cause.]

### APPEAL BOND

Know All Men by These Presents :

That we, Henry J. Ernst, Plaintiff, as Principal, and \$250.00 in cash deposited with the Clerk of Court, as Sureties, are held and firmly bound unto Secretary of the Interior, Solicitor, Department of the Interior, and Roy N. Mikel, Defendants, in the full and just sum of \$250.00, to be paid to the said Secretary of the Interior, Solicitor, Department of the Interior, and Roy N. Mikel, Defendants, certain attorneys, executors, administrators, or assigns; to which payment, well and truly to be made, we bind ourselves, our heirs, executors, and administrators, jointly and severally, by these presents.

Sealed with our seals and dated this 6th day of February, 1957.

Whereas, lately at a District Court of the United States for the District of Alaska, Fourth Judicial Division, in a suit pending in said Court, between the Plaintiff above named and the Defendants above named, an Order quashing the return of service of summons and dismissing the action was rendered against the Plaintiff, and the said Plaintiff having filed in said Court a Notice of Appeal to reverse the Order in the aforesaid suit on appeal to United States Circuit Court of Appeals to be holden at San Francisco, in the State of California.

Now, the condition of the above obligation is such, That if the said Plaintiff above named shall

prosecute his appeal to effect, and satisfy the judgment in full, together with costs, interest and damages for delay, if for any reason the appeal is dismissed or if the judgment is affirmed, and to satisfy in full such modification of the judgment and such costs, interest and damages as the appellate court may adjudge and award, if he fails to make his plea good, then the above obligation to be void; else to remain in full force and virtue.

[Seal]     /s/ HENRY J. ERNST,  
Principal, Plaintiff.

\$250.00 in cash deposited with the Clerk of the Court, Sureties.

Acknowledged before me the day and year first above written.

[Seal]     /s/ IRENE D. BODDY,  
Notary Public in and for  
Alaska.

My commission expires 1/4/58.

[Endorsed]: Filed February 6, 1957.

---

[Title of District Court and Cause.]

#### STATEMENT OF POINTS

Pursuant to the provisions of the Federal Rules of Civil Procedure and of the United States Court of Appeals for the Ninth Circuit, the Appellant herewith states the points on which he intends to rely, in this appeal, as follows:

1. The Trial Court erred in granting the motion to quash the return of service of summons and to dismiss the complaint and the action, which motion had been filed by the Defendants, the Secretary of the Interior, and the Solicitor General, Department of the Interior, through the United States Attorney, Fourth Division, District of Alaska.

Dated at Fairbanks, Alaska, this 6th day of February, 1957.

/s/ MAURICE T. JOHNSON,  
Attorney for Appellant.

Receipt of Copy acknowledged.

[Endorsed]: Filed February 6, 1957.

---

[Title of District Court and Cause.]

### CERTIFICATE OF CLERK

I, John B. Hall, Clerk of the above-entitled Court, do hereby certify that the following list comprises all of the proceedings in this cause listed on the Designation of Record on Appeal of the Plaintiff and Appellant, viz:

1. Plaintiff's Complaint.
2. Summons and Return showing Service on the Secretary of Interior and Solicitor of the Department of the Interior through U. S. Attorney.
3. Summons and Return Showing Service on Defendant Roy N. Mikel.
4. Affidavit of Mailing filed, November 28, 1956.

5. Motion to Quash Return of Service of Summons and to Dismiss Complaint.
6. Answer of Defendant Roy N. Mikel.
7. Memorandum Opinion filed, Dec. 28, 1956.
8. Order to Quash Return Service of Summons and to Dismiss Complaint.
9. Notice of Appeal.
10. Bond on Appeal.
11. Statement of Points.
12. Designation of Record.

Witness my hand and the seal of the above-entitled Court this 7th day of February, 1957.

[Seal]      /s/ JOHN B. HALL,  
Clerk of Court.

---

[Endorsed]: No. 15431. United States Court of Appeals for the Ninth Circuit. Henry J. Ernst, Appellant, vs. Secretary of the Interior, Solicitor, Department of the Interior, and Roy N. Mikel, Appellees. Transcript of Record. Appeal From the District Court for the District of Alaska, Fourth Division.

Filed: February 11, 1957.

/s/ PAUL P. O'BRIEN,  
Clerk of the United States Court of Appeals for the  
Ninth Circuit.





No. 15432

---

United States  
Court of Appeals  
for the Ninth Circuit

---

COMMISSIONER OF INTERNAL REVENUE,  
Petitioner,

vs.

MILDRED IRENE SIEGEL, Respondent.

---

Transcript of Record

---

. Petition to Review a Decision of The Tax Court of the  
United States

FILED

APR 19 1957

PAUL P. O'BRIEN, CLERK



No. 15432

---

---

United States  
Court of Appeals  
for the Ninth Circuit

---

COMMISSIONER OF INTERNAL REVENUE,  
Petitioner,

vs.

MILDRED IRENE SIEGEL, Respondent.

---

Transcript of Record

---

Petition to Review a Decision of The Tax Court of the  
United States

---

---



## INDEX

[Clerk's Note: When deemed likely to be of an important nature, errors or doubtful matters appearing in the original certified record are printed literally in italic; and, likewise, cancelled matter appearing in the original certified record is printed and cancelled herein accordingly. When possible, an omission from the text is indicated by printing in italic the two words between which the omission seems to occur.]

	PAGE
Answer to Petition for Redetermination of Deficiency .....	16
Appearances .....	3
Certificate of Clerk to Transcript of Record ..	49
Decision .....	42
Designation of Transcript of Record .....	48
Adoption of (USCA).....	103
Docket Entries .....	3
Findings of Fact and Opinion .....	30
Names and Addresses of Attorneys .....	1
Order Enlarging Time .....	49
Petition for Redetermination of Deficiency ...	6
Exhibit A—Notice of Deficiency .....	12
Petition for Review .....	43
Notices of Filing .....	45, 46
Statement of Points to be Relied Upon .....	47
Adoption of (USCA) .....	103

ii.

Stipulation of Facts .....	18
Joint Exhibit 1-A—Last Will and Testament of Irving Siegel .....	22
Transcript of Proceedings and Testimony ....	50
Exhibit 1 (Joint)—Stipulation of Facts and Attached Last Will and Testament of Irv- ing Siegel .....	18-29
Admitted in Evidence .....	68
Exhibits for Petitioner:	
2—Expenses from Jan. 1 to Dec. 31, 1948, Irving and Mildred Siegel .....	95
Admitted in Evidence .....	73
3—Cash Account for 1949, Mildred Siegel	96
Admitted in Evidence .....	76
4—Cash Account for 1950, Mildred Siegel	97
Admitted in Evidence .....	77
5—Cash Account for 1951 .....	98
Admitted in Evidence .....	77
6—Cash Account for 1952 .....	99
Admitted in Evidence .....	77
7—Cash Account for 1953 .....	100
Admitted in Evidence .....	77
8—Cash Account for 1954 .....	101
Admitted in Evidence .....	77
Opening Statement of Mr. Burke .....	58
Opening Statement of Mr. Latham .....	51

## Transcript of Proceedings—(Continued):

## Witnesses:

Siegel, Mildred Irene

—direct ..... 69

—cross ..... 82

Weingart, Ben

—direct ..... 87

—cross ..... 91





CHARLES K. RICE,  
Assistant Attorney General,

LEE A. JACKSON,  
Attorney,  
Justice Department,  
Washington 25, D. C.  
Attorneys for Petitioner.

DANA LATHAM,  
A. R. KIMBROUGH,  
GROVER R. HEYLER,  
830 Statler Center,  
900 Wilshire Blvd.,  
Los Angeles 17, California,  
Attorneys for Respondent.



The Tax Court of the United States

Docket No. 52700

MILDRED IRENE SIEGEL,           Petitioner,

vs.

COMMISSIONER OF INTERNAL REVENUE,  
Respondent.

Appearances:

For Petitioner:

A. R. Kimbrough, Esq., Austin H. Peck,  
Jr., Esq., Henry C. Diehl, Esq., Dana  
Latham, Esq., Grover R. Heyler, Esq.

For Respondent:

John J. Burke, Esq.

DOCKET ENTRIES

1954

Apr. 29—Petition received and filed. Taxpayer notified. Fee paid.

Apr. 29—Copy of petition served on General Counsel.

Apr. 29—Request for Circuit hearing in Los Angeles filed by taxpayer. 5/5/54—Granted.

Jun. 22—Answer filed by General Counsel.

Jun. 22—Request for hearing in Los Angeles, Calif., filed by General Counsel.

Jun. 23—Copy of answer and request served on taxpayer, Los Angeles, Calif.

1955

Mar. 25—Hearing set July 5, 1955, Los Angeles, Calif.

4 *Commissioner of Internal Revenue vs.*

1955

- Apr. 6—Entry of appearance of Dana Latham and Grover R. Heyler, as counsel, filed.
- Apr. 18—Notice of change of hearing date to June 20, 1955, Los Angeles, Calif.
- Jun. 20—Hearing had before Judge Black on the merits, Stipulation of Facts and Exhibit 1-A. Briefs due 9/1/55; Replies due 9/30/55.
- July 13—Transcript of Hearing 6/20/55 filed.
- Aug. 30—Motion for extension to Sept. 15, 1955 to file brief filed by General Counsel, 8/31/55—Granted.
- Sept. 1—Brief filed by taxpayer.
- Sept. 13—Motion for extension to 10/6/55 to file brief, filed by General Counsel. 9/14/55—Granted.
- Oct. 4—Motion for extension to 10/27/55 to file brief, filed by General Counsel. 10/5/55—Granted.
- Oct. 28—Motion for extension to 11/3/55 to file brief, filed by General Counsel. 10/31/55 Granted.
- Nov. 3—Brief filed by Respondent. Served 11/4/55.
- Nov. 4—Copy of brief served on Respondent.
- Dec. 2—Reply Brief filed by taxpayer. 12/5/55 Copy served.
- Dec. 5—Motion for extension to Dec. 17, 1955 to file reply brief filed by Respondent. 12/6/55—Granted.

1955

Dec. 16—Motion for extension to Dec. 31, 1955 to file reply brief filed by Respondent. 12/21/55—Granted.

1956

Jan. 3—Motion for extension of time to 1/14/56 to file reply brief, filed by Respondent. 1/4/56—Granted.

Jan. 16—Reply Brief filed by Respondent. Served 1/17/56.

Jun. 29—Findings of Fact and Opinion filed. Judge Black. Decision will be entered under Rule 50. Served 6/29/56.

Oct. 2—Agreed computation filed.

Oct. 3—Decision entered, Judge Black. Served 10/4/56.

Dec. 20—Petition for Review by U. S. Court of Appeals for the Ninth Circuit filed by Respondent.

1957

Jan. 3—Proof of Service filed (Counsel).

Jan. 3—Proof of Service filed (Taxpayer).

Jan. 15—Motion for extension of time for filing record on review and docketing petition for review to Mar. 20, 1957 filed by Respondent.

Jan. 16—Order extending time for filing record on review and docketing petition for review to March 20, 1957, entered.

Jan. 17—Order served.

Jan. 23—Designation of contents of record on review, with proof of service thereon filed.

1957

Jan. 23—Statement of Points with Proof of Service thereon, filed.

[Title of Tax Court and Cause.]

## PETITION

The above-named petitioner hereby petitions for a redetermination of the deficiency set forth by the Commissioner of Internal Revenue in his notice of deficiency A:R:90D:SWP dated February 8, 1954, and as a basis of her proceeding alleges as follows:

### I.

Petitioner is an individual residing at 406 South June Street, Los Angeles, California. Petitioner's gift tax return for the period here involved was filed with the Collector of Internal Revenue for the Sixth District of California, at Los Angeles.

### II.

The notice of deficiency, a copy of which is attached hereto and marked Exhibit "A", was mailed to petitioner on February 8, 1954.

### III.

The taxes in controversy are gift taxes for the calendar year 1950 in the amount of \$51,144.24. The entire amount of said deficiency is in dispute.

### IV.

The determination of tax set forth in said notice of deficiency is based upon the following errors:

(a) Respondent erred in determining that peti-

tioner is liable for deficiency in gift tax of \$51,144.24, or in any amount for the calendar year 1950.

(b) Respondent erred in determining that petitioner made a completed or irrevocable transfer of property by gift during said calendar year.

(c) Respondent erred in determining that petitioner, during said calendar year, transferred to her son by gift a remainder interest in all or any part of her one-half interest in the community property of herself and her deceased husband.

(d) Respondent erred in determining the value of petitioner's said one-half interest in said community property, and in determining the value of said remainder interest.

(e) Respondent erred in failing to determine that the value of the life estate which petitioner obtained in her deceased husband's one-half interest in said community property constituted consideration in money or money's worth for any said transfer.

(f) Respondent erred in failing to determine that all bequests which petitioner became entitled to and obtained under the provisions of the last Will of said decedent constituted consideration in money or money's worth for any said transfer.

(g) Respondent erred in determining that no exclusion was allowable within the meaning of Section 1003(b)(3) of the Internal Revenue Code with respect to any said transfer.

## V.

The facts upon which the petitioner relies as the basis of this proceeding are as follows:

(a) Petitioner's husband died January 4, 1949, leaving an estate composed entirely of the community property of himself and petitioner acquired after 1927.

(b) Said decedent's last Will was duly probated on or about February 3, 1949. Said decedent purported, by said Will, to dispose of the entire community property of decedent and petitioner. Under the terms of said Will petitioner was entitled to receive certain bequests and to become life beneficiary of a residuary trust, if, but only if, petitioner elected to permit her property to pass according to the terms of the Will. The material provisions of the Will relating to said trust are as follows:

"Seven: All the rest, residue and remainder of my estate I give, devise and bequeath to my wife, Mildred Irene Siegel, Ben Weingart and N. B. Alison, or the survivor of them, In Trust, however, for the uses and purposes hereinafter specified and not otherwise:

"(a) To pay to my beloved wife, Mildred Irene Siegel, for the support, maintenance and care of herself and our beloved son, Richard Bruce Siegel, such sums as in the sole discretion of the majority of said trustees they deem proper to maintain at least the same standard of living to which she has been accustomed in recent years, but in no event less than the sum of One Thousand (\$1,000.00) Dollars per month;

\* \* \* \* \*

"(c) In the event the net income from my trust estate is not sufficient to make the payments above



provided, then and in that event I specifically authorize my Trustees to make payments from the corpus of said trust estate to the extent necessary to provide for the payments as above set forth;

“(d) The said trustees shall be the sole judges and it shall be in their sole discretion as to what constitutes income to said trust;

\* \* \* \* \*

“(j) I specifically direct that during the life of the three trustees herein named, a majority thereof shall be authorized to act for and on behalf of said trustees, while if two living it shall require their unanimous approval, and if they are not able to agree, then either may petition the Court having jurisdiction of the probate of my estate for instructions;

\* \* \* \* \*

“(l) Upon the termination of said trust, I specifically direct that the corpus of said trust remaining shall by my said trustees be paid out and distributed as follows: To my said beloved son, Richard Bruce Siegel, if living, otherwise to his lawful issue, if any, share and share alike; in the event of the death of my beloved son prior thereto, without lawful issue, then the residue of my trust estate shall by my said trustees be distributed one-half ( $\frac{1}{2}$ ) thereof to those who would then be my heirs at law if my death had occurred at the time of the termination of said trust and one-half ( $\frac{1}{2}$ ) thereof to those who would then be my wife's heirs at law, if her death had occurred at the same time, if my said beloved wife takes under this will in lieu of her

community rights and if she elects to take by reason of her community rights and not under the will, then the whole thereof shall be distributed to those who would then be my heirs at law if my death had occurred at the time of the termination of said trust.”

(c) On or about January 5, 1950, petitioner filed with the court in which said estate was being administered, her written election to take under said Will in lieu of any and all community property rights which she might have in said estate. Petitioner filed such election so that she would be entitled to said bequests, including the life interest in her husband's one-half of the community property, which were available to her only if she elected to take under such Will and not to take her community share.

(d) The gross value of the community property of decedent and petitioner, as determined for federal estate tax purposes, was \$1,422,897.14. The amount of the debts and administration expenses chargeable to the principal of said estate and paid through March 31, 1954 was approximately \$438,878.97. The value of the one-half share of community property to which petitioner would have been entitled after administration would not exceed \$490,000.

(e) On or about January 31, 1950, a partial distribution of property of the value of \$668,714.75 was made to petitioner, Ben Weingart and N. V. Alison, as trustees under the Will of said decedent, to be held by them according to the terms of the

trust established by said Will. Not more than one-half of said property, or \$334,357.38, represented petitioner's community share. No other distribution to said trust has been made by said estate or petitioner. As part of said partial distribution petitioner received two Cadillac automobiles of the value of \$7,000, which were the community property of petitioner and decedent. Thereafter, in August, 1950, petitioner received the sum of \$35,000 from said estate in payment of the legacy bequeathed to her by decedent. As of March 31, 1954, cash and property of the value of approximately \$298,372.47 still remained in said estate. Of said amount not more than \$150,000 represented petitioner's community share.

(f) Petitioner has been paid the following amounts by said trustees under the terms of said testamentary trust: in 1950, \$24,000; in 1951, \$54,000; in 1952, \$54,000; in 1953, \$52,000. Payments for said trust in the amount of not less than \$54,000 per year are required by petitioner to maintain herself in the standard of living to which she was accustomed in the years immediately preceding her husband's death, and petitioner is entitled to annual payments from the trust in the future of like amounts.

(g) Petitioner was born February 21, 1902. Richard Bruce Siegel, the son of petitioner and decedent, was born May 14, 1943.

Wherefore, petitioner prays that this Court may

hear the proceedings and determine that respondent erred as set forth in paragraph IV herein.

Dated: April 19, 1954.

/s/ A. R. KIMBROUGH,  
/s/ AUSTIN H. PECK, JR.,  
/s/ HENRY C. DIEHL,  
Counsel for Petitioner

Duly Verified.

EXHIBIT "A"

Form 1230

U. S. Treasury Department, Internal Revenue Service, District Director, Chief, Audit Division, Post Office Box 231—Main Office, Los Angeles 53, California. Feb. 8, 1954

In replying refer to: A:R:90D:SWP MI 8111, Ext. 400

Mildred Irene Siegel, Donor  
406 South June Street  
Los Angeles 5, California

Dear Mrs. Siegel:

You are advised that the determination of your gift tax liability for the calendar year 1950 discloses a deficiency of \$51,144.24, as shown in the statement attached.

In accordance with the provisions of existing internal revenue laws, notice is hereby given of the deficiency or deficiencies mentioned.

Within 90 days from the date of the mailing of this letter you may file a petition with The Tax

Court of the United States, at its principal address, Washington 4, D. C., for a redetermination of the deficiency. In counting the 90 days you may not exclude any day unless the 90th day is a Saturday, Sunday, or legal holiday in the District of Columbia in which event that day is not counted as the 90th day. Otherwise Saturdays, Sundays, and legal holidays are to be counted in computing the 90-day period.

Should you not desire to file a petition, you are requested to execute the enclosed form and forward it to the District Director of Internal Revenue, Chief, Audit Division, P. O. Box 231, Main Office, Los Angeles 53, Calif. The signing and filing of this form will expedite the closing of your return by permitting an early assessment of the deficiency and will prevent the accumulation of interest, since the interest period terminates 30 days after receipt of the form, or on the date of assessment, or on the date of payment, whichever is earlier.

Very truly yours,

T. Coleman Andrews  
Commissioner

By R. A. Riddell  
District Director of Internal  
Revenue

Enclosures:

Statement, Form 1276, Agreement Form.

Statement

Gift tax year: 1950; Liability, \$51,144.24; Assessed, none; Deficiency, \$51,144.24.

In making this determination of Federal gift tax liability of the above-named donor, careful consideration has been given to the information on file in this office.

## Year 1950

## Adjustments to Net Gifts

Schedule A of return	Returned	Determined
Total gifts of donor .....	.00	\$287,788.51
Less: total exclusions .....	.00	.00
	<hr/>	<hr/>
Total amount of included gifts.....	.00	\$287,788.51
Less: specific exemption .....	.00	30,000.00
	<hr/>	<hr/>
Net gifts .....	.00	\$257,788.51

## Explanation of Adjustments

## Schedule A—

The transfer by the above-named donor to her son of a remainder interest in her one-half interest in community property which she transferred to a testamentary trust established under the last will and testament of Irving Siegel, Deceased, is determined to constitute a transfer by said donor without consideration in money or money's worth, and a gift within the meaning of Section 1000 of the Internal Revenue Code.

The value of such remainder interest is determined on the basis of the present worth factor, .46002, or the present value of \$1.00 due at the end of the year of death of a person of the age of the donor who was born February 21, 1902. The value of such remainder interest is determined and computed as follows:

Determined value of donor's one-half interest in community property, \$625,600.00, times .46002 or, \$287,788.51.

It is determined that no exclusion is allowable within the meaning of Section 1003(b)(3) of the Internal Revenue Code. The gift in trust, being limited to commence in use, possession, and enjoyment at some future date, is determined to represent a future interest within the meaning of said section of the Code. In accordance with the provisions of Section 1004(a)(1) (as amended by Section 455 of the Revenue Act of 1942) the amount of \$30,000.00 is allowed as Specific Exemption in the computation of the gift taxes with respect to said calendar year 1950.

#### Computation of Gift Tax

	Returned	Determined
Net Gifts for 1950 .....	.00	\$257,788.51
Total net gifts for preceding years.....	.00	.00
	.00	\$257,788.51
Total net gifts .....	.00	\$257,788.51
	.00	\$ 51,144.24
Tax on total net gifts.....	.00	\$ 51,144.24
	.00	.00
Less tax on net gifts for preceding years....	.00	.00
	.00	\$ 51,144.24
Total tax payable for 1950.....	.00	\$ 51,144.24
Total tax assessed .....		.00
		\$ 51,144.24
Deficiency .....		\$ 51,144.24

[Endorsed]: T.C.U.S. Filed April 29, 1954.

[Title of Tax Court and Cause.]

### ANSWER

The Commissioner of Internal Revenue, by his attorney, Daniel A. Taylor, Chief Counsel, Internal Revenue Service, for answer to the petition of the above-named taxpayer, admits and denies as follows:

I to III, inclusive

Admits the allegations contained in paragraphs I to III, inclusive, of the petition.

#### IV.

(a) to (g), inclusive. Denies the allegations of error contained in subparagraphs (a) to (g), inclusive, of paragraph IV of the petition.

#### V.

(a) Admits petitioner's husband died January 4, 1949, leaving an estate of community property of himself and petitioner; denies for lack of sufficient information the remaining allegations contained in subparagraph (a) of paragraph V of the petition.

(b) Admits petitioner's husband's last Will was duly probated on or about February 3, 1949; admits those provisions set out in subparagraph (b) of petitioner's deceased husband's Will; denies for lack of sufficient information the remaining allegations contained in subparagraph (b) of paragraph V of the petition.

(c) to (f), inclusive. Denies for lack of sufficient information the allegations contained in subpara-



graphs (c) to (f), inclusive, of paragraph V of the petition.

(g) Admits petitioner was born February 21, 1902; denies for lack of sufficient information the remaining allegations contained in subparagraph (g) of paragraph V of the petition.

VI.

Denies generally and specifically each and every allegation contained in the petition not hereinbefore expressly admitted, qualified or denied.

Wherefore, it is prayed that the determination of the Commissioner be approved.

/s/ DANIEL A. TAYLOR, ECC  
Chief Counsel, Internal Revenue  
Service

Of Counsel:

Woolvin Patten, Acting Regional Counsel  
E. C. Crouter, Assistant Regional Counsel,  
R. E. Maiden, Jr., Special Assistant to Regional  
Counsel,  
John J. Burke, Special Attorney, Internal Revenue Service.

[Endorsed]: T.C.U.S. Filed June 22, 1954.

[Title of Tax Court and Cause.]

### STIPULATION OF FACTS

Petitioner and respondent, through their respective counsel of record, hereby stipulate and agree that the facts hereinafter set forth are true:

(1) Petitioner herein, Mildred I. Siegel, is an individual residing in the City of Los Angeles, California. Petitioner's Gift Tax return for the period here involved was timely filed with the Collector of Internal Revenue for the Sixth District of California, at Los Angeles. The tax in controversy is a Gift Tax for the calendar year 1950 in the amount of \$51,144.24, and the entire amount of said deficiency is in dispute.

(2) Petitioner is the widow of Irving Siegel, who died January 4, 1949. Petitioner was born on February 21, 1902. Petitioner and said decedent had one son, Richard Bruce Siegel, who was born on May 14, 1943, and who presently resides with petitioner.

(3) Said decedent left an estate consisting of community property. All of said community property was acquired by petitioner and decedent after 1927. The value of said community property on the date of decedent's death was \$1,422,897.14, and the value of petitioner's half share therein was \$711,448.57.

(4) Said decedent's last will was duly probated on February 3, 1949, in the Superior Court, County of Los Angeles, California. A true copy of said will is attached hereto as Joint Exhibit "1-A".

(5) On January 5, 1950, petitioner filed with said Court a document of which the following is a true copy:

“Election of Widow to Take Under Will

I, the undersigned, Mildred I. Siegel, widow of Irving Siegel, deceased, do hereby elect to take under the Last Will and Testament of said deceased in lieu of any and all community property rights which I have in said estate.

Dated this 5th day of January, 1950.

Mildred Irene Siegel

(Mildred Irene Siegel)”

(6) On January 31, 1950 said Court ordered partial distribution of said estate and pursuant to said order property of the fair market value of \$651,630.34 was distributed to petitioner, Ben Weingart and N. V. Alison, as trustees under the will of said decedent, to be held by them according to the terms of the trust established by said will. All of said property so distributed had been the community property of Petitioner and decedent prior to decedent's death, and all of said property consisted of real and personal property other than money. No other distribution to said trust has been made by said estate or said Petitioner.

(7) The administration of said estate has not yet been closed but is about to be closed. In the course of administration, said estate has disbursed the following amounts which are apportionable as indicated between Petitioner's one-half share of the community property and decedent's one-half share thereof:

(a) On account of debts and administration expenses the sum of \$229,772.50; one-half of said sum, or \$114,886.25, is chargeable against Petitioner's said share and the other one-half against decedent's said share.

(b) On account of federal estate tax, the sum of \$201,840.48, which sum is chargeable solely against decedent's said share.

(c) On account of inheritance tax imposed on the bequests to decedent's son and relatives other than Petitioner, the sum of \$26,145.30, which sum is chargeable solely against decedent's said share.

(d) On account of inheritance tax imposed upon transfers to petitioner, the sum of \$9,026.88, which sum is chargeable against Petitioner's said share.

(e) Pursuant to the terms of said will, legacies to persons other than Petitioner in the sum of \$35,000, which sum is chargeable solely against decedent's said share.

(f) Pursuant to the terms of said will, property (automobiles) to Petitioner, which property was of the value of \$7,000; one-half of said sum, or \$3,500, is chargeable against Petitioner's said share and one-half against decedent's said share.

(8) In the course of administration, the sum of \$35,000 cash was paid to Petitioner pursuant to the terms of said will. Petitioner contends that all of said amount is chargeable against her said share and respondent contends that all of said amount is chargeable to decedent's said share.

(9) The balance of the property remaining in the estate, determined by subtracting the expenditures

and distributions hereinabove set forth from the total community property of decedent and Petitioner, will be distributed to the aforesaid trustees to be held in trust pursuant to the provisions of said will.

(10) In the course of administration, said estate has received, on account of decedent's half interest in the community property, net income in the amount of \$27,319.25. Said amount will be distributed to the aforesaid trustees to be held in trust pursuant to the provisions of said will. Said estate has also received net income in the amount of \$36,642.60 on account of Petitioner's half interest, which amount will be distributed outright to Petitioner.

(11) Petitioner has been paid the following amounts by said trustees under the terms of said testamentary trust: in 1950, \$24,000; in 1951, \$54,000; in 1952, \$54,000; in 1953, \$52,000; in 1954, \$48,000. In the year 1950 Petitioner received from the estate of said decedent a family allowance of \$18,000 in addition to the sum received from said trustees.

(12) The value of the life interest of Petitioner in property in which Petitioner had a life interest in 1950 would be determined by multiplying the value of such property by 4% and multiplying the product by the factor 13.03942. The value of a remainder interest commencing upon the termination of Petitioner's life interest in any such property in 1950 would be determined by multiplying the value of said property by the factor .46002. If

Petitioner's son had an enforceable right of support from said trust, then the value of said right in 1950 would be determined by multiplying the annual cost of such support by (a) the factor 13.03942 if said right existed for Petitioner's life, or (b) the factor 11.11839 if said right existed for said son's minority.

(13) This stipulation shall not prevent the introduction of any additional evidence by either of the parties hereto, and the fact that any fact has been stipulated to hereinabove shall not be deemed to be an indication by either party that such fact is material and shall not prevent either party from objecting to the materiality of such fact upon the trial of this action.

Dated: June 20, 1955.

/s/ DANA LATHAM,

Attorney for Petitioner

/s/ JOHN POTTS BARNES, REM

Chief Counsel, Internal Revenue  
Service

JOINT EXHIBIT No. 1-A

LAST WILL AND TESTAMENT OF  
IRVING SIEGEL

In the Name of God, Amen:

I, Irving Siegel, of the City and County of Los Angeles, State of California, being of sound and disposing mind, memory and understanding, and not acting under restraint or undue influence, do make, publish and declare this to be my Last Will

and Testament, hereby revoking all other wills and codicils by me heretofore made.

One: I hereby direct my Executors hereinafter named to pay all my just debts and funeral expenses as soon after my demise as can be lawfully and conveniently done.

Two: I hereby state and declare that I am married, that my wife's name is Mildred Siegel, and we have one son, Richard Bruce Siegel, whom we heretofore legally adopted.

Three: I give, devise and bequeath to my beloved wife, Mildred Irene Siegel, the property which I may be occupying at the time of my death as my home, together with the furniture, furnishings and equipment located therein, all my personal effects as well as any automobiles which I may own at the time of my death, and in addition thereto I give, devise and bequeath to my said wife, the sum of Thirty-five Thousand (\$35,000.00) Dollars, which bequest is made primarily to offset the thirty-five thousand dollars which I am hereinafter bequeathing to my sisters and nephew, to the end that she may either retain this sum for her own use and benefit or divide it among her relatives in such manner as she may see fit.

Four: I give, devise and bequeath to my beloved sister, Anne Hoffman, the sum of Fifteen Thousand (\$15,000.00) Dollars.

Five: I give, devise and bequeath to my beloved sister, Jean Sefman, the sum of Fifteen Thousand (\$15,000.00) Dollars.

Six: I give, devise and bequeath to my nephew,

Gary Hoffman, the sum of Five Thousand (\$5,000.00) Dollars.

Seven: All the rest, residue and remainder of my estate I give, devise and bequeath to my wife, Mildred Irene Siegel, Ben Weingart and N. B. Alison, or the survivor of them, In Trust, however, for the uses and purposes hereinafter specified and not otherwise:

(a) To pay to my beloved wife, Mildred Irene Siegel, for the support, maintenance and care of herself and our beloved son, Richard Bruce Siegel, such sum as in the sole discretion of the majority of said trustees they deem proper to maintain at least the same standard of living to which she has been accustomed in recent years, but in no event less than the sum of One Thousand (\$1,000.00) Dollars per month.

(b) In the event of the death of my beloved wife prior to the termination of this trust, my said trustees are hereby authorized to pay out and expend for the support, maintenance, care and education of my beloved son, Richard Bruce Siegel, such sums as in the sole discretion of the majority of said trustees they deem proper, but in no event less than Fifty (\$50.00) Dollars per week; the insertion of this minimum, however, shall in no event constitute a limitation on the money to be so expended as it is my desire that my said trustees shall be very liberal in such disbursements, to the end that my said beloved son will be well provided for, as well as obtain a good university education;

(c) In the event the net income from my trust



estate is not sufficient to make the payments above provided, then and in that event I specifically authorize my Trustees to make payments from the corpus of said trust estate to the extent necessary to provide for the payments as above set forth;

(d) The said trustees shall be the sole judges and it shall be in their sole discretion as to what constitutes income to said trust;

(e) The trust hereby created shall terminate and end upon the happening of any of the following events:

1. Upon the death of my beloved wife, Mildred Irene Siegel, if my beloved son, Richard Bruce Siegel, does not survive my said wife;

2. Upon the death of my wife, Mildred Irene Siegel, provided my said son, Richard Bruce Siegel, has then attained the age of thirty-one (31) years.

3. Upon the death of my beloved son, Richard Bruce Siegel, subsequent to the death of my beloved wife prior to such a time as he attains the age of thirty-one (31) years;

4. Upon my said son, Richard Bruce Siegel, attaining the age of thirty-one (31) years, if my said beloved wife, Mildred Irene Siegel, is not then living.

(f) In the event of the death of my said beloved wife, Mildred Irene Siegel, prior to such a time as my beloved son attains the age of twenty-one (21) then and in such event upon his attaining the age of twenty-one one-third ( $\frac{1}{3}$ ) of the corpus of said trust estate shall by my said trustees be distributed to him, and upon his attaining the age of

twenty-six (26) years, one-half ( $\frac{1}{2}$ ) of the remaining corpus of said trust estate;

(g) In the event of the death of my beloved wife after my said beloved son attains the age of twenty-one, but before attaining the age of twenty-six years, I specifically direct that one-third ( $\frac{1}{3}$ ) of the corpus of said trust estate shall be distributed to my said beloved son upon the death of my beloved wife, and upon his attaining the age of twenty-six (26) there shall be distributed to him one-half of the remaining corpus of said trust estate.

(h) In the event of the death of my beloved wife after my said beloved son attains the age of twenty-six years, but before attaining the age of thirty-one years, I specifically direct that two-thirds ( $\frac{2}{3}$ ) of the corpus of said trust estate shall be distributed to my said beloved son upon the death of my beloved wife;

(i) To carry out the express purposes of this trust, after they have assumed full management thereof, and in the aid of its execution and the proper administration management and disposition of the trust estate, the trustees are vested with general powers and discretions as though they, individually, were the owners of the trust estate, to manage, control, sell, convey, partition, divide, subdivide, exchange, improve and repair said trust property in such manner and in accordance with such procedure as they may deem advisable, and to lease the trust estate, or any part thereof, within or extending beyond the duration of this trust;

(j) I specifically direct that during the life of the three trustees herein named, a majority thereof shall be authorized to act for and on behalf of said trustees, while if two living it shall require their unanimous approval, and if they are not able to agree, then either may petition the Court having jurisdiction of the probate of my estate for instructions;

(k) In the event of the death of the survivor of my said trustees hereinbefore designated, prior to the termination of this trust, I hereby nominate and appoint The Farmers and Merchants National Bank of Los Angeles as Trustee;

(l) Upon the termination of said trust, I specifically direct that the corpus of said trust remaining shall by my said trustees be paid out and distributed as follows: To my said beloved son, Richard Bruce Siegel, if living, otherwise to his lawful issue, if any, share and share alike; in the event of the death of my beloved son prior thereto, without lawful issue, then the residue of my trust estate shall by my said trustees be distributed one-half ( $\frac{1}{2}$ ) thereof to those who would then be my heirs at law if my death had occurred at the time of the termination of said trust and one-half ( $\frac{1}{2}$ ) thereof to those who would then be my wife's heirs at law, if her death had occurred at the same time, if my said beloved wife takes under this will in lieu of her community rights and if she elects to take by reason of her community rights and not under the will, then the whole thereof shall be distributed to those who would then be my heirs at law if my

death had occurred at the time of the termination of said trust.

Eight: The provisions made in this my Last Will and Testament for my beloved wife, Mildred Irene Siegel, are in lieu of her community rights and interest, and if she elects to take her community interest, in lieu of taking under this my Last Will and Testament, then the bequests made to her in paragraph Three hereof shall be of no force and effect and the real and personal property so bequeathed shall become a part of the rest, residue and remainder of my said estate to be distributed to my said trustees, and likewise subdivision (a) of paragraph Seven shall be of no force and effect and she shall take nothing as a beneficiary under said trust.

Nine: In the event of my death, and the death of my beloved wife thereafter prior to such a time as she shall have nominated and appointed, by will or otherwise, a guardian of the person of our beloved son, Richard Bruce Siegel, I hereby nominate and appoint my sister, Anne Hoffman, as guardian of the person of my said son, Richard Bruce Siegel.

Ten: I hereby nominate and appoint my beloved wife, Mildred Irene Siegel, Ben Weingart and N. B. Alison, or the survivor of them, as executors of this my Last Will and Testament to act without bond.

Eleven: If any person who is, or claims under or through, a devisee, legatee, or beneficiary under this will, or any person who if I had died intestate

would be entitled to share in my estate, shall, in any manner whatsoever, directly or indirectly contest this Will or attack, oppose or seek to impair or invalidate any provision hereof, or conspire or cooperate with anyone attempting to do any of the acts or things aforesaid, then I hereby bequeath to each such person the sum of One Dollar only, and all other bequests, devises and interests in this Will given to such person shall be forfeited and be distributed as the rest, residue and remainder of my estate.

In Witness Whereof, I have hereunto set my hand this 31st day of March, 1948.

/s/ Irving Siegel, Testator

Irving Siegel on the 31st day of March, 1948, in our presence and in the presence of each of us, acknowledged to us that his signature to the foregoing instrument, consisting of six (6) pages, was made by him on the date hereof, and at the same time and in our presence and in the presence of each of us declared that said instrument was his Last Will and Testament, and at his request and in his presence and in the presence of each other, we subscribed our names as witnesses hereto this 31st day of March, 1948.

/s/ Louis H. Boyor

Residing at 813 Holbell Rd.

/s/ H. D. Poirier

Residing at 1624 S. St. Andrews

[Endorsed]: T.C.U.S. Filed June 20, 1955.

Tax Court of the United States

26 T. C. No. 91

Mildred Irene Siegel, Petitioner, vs. Commissioner  
of Internal Revenue, Respondent.

Docket No. 52700

Filed June 29, 1956

FINDINGS OF FACT AND OPINION

Petitioner's husband provided in his will that, in lieu of her taking her approximate \$584,000 share in their community property under California law, she was to receive (1) a bequest of \$35,000 and (2) payments for life from a residuary trust established under the will. Petitioner elected to take under the will. Respondent determined that, as a result of such election, she made a gift to the remainderman (her son) under the testamentary trust of the reversionary interest in her \$584,000 share of community property. Held, a gift was made to the remainderman to the extent of petitioner's community one-half of the principal less the life estate reserved by her therein, reduced by the value of the life estate received by her in the husband's part of the community property conveyed to the testamentary trust, plus \$35,000 bequest in cash which she received under the will.

Dana Latham, Esq., and Grover R. Heyler, Esq.,  
for the petitioner.

John J. Burke, Esq., for the respondent.

The Commissioner determined a deficiency of \$51,144.24 in petitioner's gift tax for 1950. The

Commissioner's determination is based upon an adjustment explained in the deficiency notice as follows:

The transfer by the above-named donor to her son of a remainder interest in her one-half interest in community property which she transferred to a testamentary trust established under the last will and testament of Irving Siegel, Deceased, is determined to constitute a transfer by said donor without consideration in money or money's worth, and a gift within the meaning of Section 1000 of the Internal Revenue Code.

The value of such remainder interest is determined on the basis of the present worth factor, .46002, or the present value of \$1.00 due at the end of the year of death of a person of the age of the donor who was born February 21, 1902. The value of such remainder interest is determined and computed as follows:

Determined value of donor's one-half interest in community property, \$625,600.00, times .46002 or, \$287,788.51.

Petitioner, by appropriate assignments of error, contests the Commissioner's determination.

#### Findings of Fact

Many of the facts were stipulated, are found as stipulated, and the stipulation is incorporated herein by reference.

Petitioner is an individual residing in Los Angeles, California. Her gift tax return for 1950 was timely filed with the then collector of internal revenue for the sixth district of California.

Petitioner was born on February 21, 1902. She is the widow of Irving Siegel (hereinafter sometimes referred to as Irving) who died on January 4, 1949. She and Irving had an adopted son, Richard Bruce Siegel, who was born on May 14, 1943, and who presently resides with petitioner. Irving left an estate consisting of community property, all of which was acquired by petitioner and Irving after 1927. On the date of Irving's death the gross value of that community property was \$1,422,897.14, and the gross value of petitioner's one-half share therein was \$711,488.57.

Irving's last will was duly probated on February 3, 1949, in the Superior Court, County of Los Angeles, California. Pertinent provisions of that will follow:

Three: I give, devise and bequeath to my beloved wife, Mildred Irene Siegel, the property which I may be occupying at the time of my death as my home, together with the furniture, furnishings and equipment located therein, all my personal effects as well as any automobiles which I may own at the time of my death, and in addition thereto I give, devise and bequeath to my said wife, the sum of Thirty-five Thousand (\$35,000.00) Dollars, which bequest is made primarily to offset the thirty-five thousand dollars which I am hereinafter bequeathing to my sisters and nephew, to the end that she may either retain this sum for her own use and benefit or divide it among her relatives in such manner as she may see fit.

\* \* \* \* \*



Seven: All the rest, residue and remainder of my estate I give, devise and bequeath to my wife, Mildred Irene Siegel, Ben Weingart and N. B. Alison, or the survivor of them, In Trust, however, for the uses and purposes hereinafter specified and not otherwise:

(a) To pay to my beloved wife, Mildred Irene Siegel, for the support, maintenance and care of herself and our beloved son, Richard Bruce Siegel, such sum as in the sole discretion of the majority of said trustees they deem proper to maintain at least the same standard of living to which she has been accustomed in recent years, but in no event less than the sum of One Thousand (\$1,000.00) Dollars per month;

\* \* \* \* \*

(c) In the event the net income from my trust estate is not sufficient to make the payments above provided, then and in that event I specifically authorize my Trustees to make payments from the Corpus of said trust estate to the extent necessary to provide for the payments as above set forth;

\* \* \* \* \*

(j) I specifically direct that during the life of the three trustees herein named, a majority thereof shall be authorized to act for and on behalf of said trustees, while if two living it shall require their unanimous approval, and if they are not able to agree, then either may petition the Court having jurisdiction of the probate of my estate for instructions;

\* \* \* \* \*

Eight: The provisions made in this my Last Will and Testament for my beloved wife, Mildred Irene Siegel, are in lieu of her community rights and interest, and if she elects to take her community interest, in lieu of taking under this my Last Will and Testament, then the bequests made to her in Paragraph Three hereof shall be of no force and effect and the real and personal property so bequeathed shall become a part of the rest, residue and remainder of my said estate to be distributed to my said trustees, and likewise subdivision (a) of paragraph Seven shall be of no force and effect and she shall take nothing as a beneficiary under said trust.

On January 5, 1950, petitioner duly executed and filed with the aforementioned Superior Court a document in which she elected to take under Irving's last will in lieu of any and all community property rights she had in the community estate. She did this in order to be able to maintain her accustomed standard of living, which she felt could not be done solely from the income from her share of the community property. On January 5, 1950, the respective net values of Irving's and petitioner's shares in the community property destined to fall into the trust created under paragraph "Seven" of Irving's will were as follows:<sup>1</sup>

---

<sup>1</sup> The parties agree that hindsight may be availed of and expenditures not actually made until after January 5, 1950, should be considered in arriving at the net values as of that date.

	Irving's Share	Petitioner's Share
Gross value at Irving's death .....	\$711,448.57	\$711,448.57
Less:		
Debts and administration expenses.....	114,886.25	114,886.25
Federal estate tax .....	201,840.48	
Inheritance taxes on bequests other than to petitioner .....	26,145.30	
Inheritance tax on bequests to petitioner		9,026.88
Legacies other than to petitioner.....	35,000.00	
Legacy to petitioner .....	35,000.00	
Automobiles bequeathed to petitioner....	3,500.00	3,500.00
	<hr/>	<hr/>
Total deductions .....	\$416,372.03	\$127,413.13
	<hr/>	<hr/>
Net value .....	\$295,076.54	\$584,035.44

Irving was a very successful businessman and he and petitioner maintained a high standard of living. In 1948, the year preceding Irving's death, their living costs were over \$46,500 before income taxes. Beginning with 1950, when petitioner elected to take under Irving's will, she has received and expended amounts from the trust thereunder as follows:

Year	Received from the Trust	Total Expenditures	Federal and State Income Taxes Included in Total Expenditures
1950	\$24,000*	\$31,720.32	\$ 4,500.00
1951	54,000	50,462.11	18,524.23
1952	54,000	43,313.60	20,296.83
1953	52,000	46,656.79	18,413.06
1954	48,000	47,267.98	22,329.39

\* Petitioner also received an \$18,000 allowance from Irving's estate in 1950.

Included in the above total expenditures were sums expended by petitioner for the support of her and Irving's son which averaged well under \$3,000 per year.

Under the economic conditions existing during the years subsequent to decedent's death and prior to this hearing it would cost petitioner \$45,000 per year, including income taxes, to maintain the standard of living to which she was accustomed in recent years prior to decedent's death.

### Opinion

Black, Judge: Respondent's position is that petitioner's January 5, 1950 election to take under Irving's will, in lieu of asserting her community property rights in the estate acquired during coverture, resulted in her making a gift to her son of a remainder interest in her one-half interest in community property which she thus transferred to a testamentary trust established under the last will and testament of Irving.<sup>2</sup> Respondent has stipulated that the net value of petitioner's community share at the date of gift was no greater than \$584,035.44 (as opposed to the value of \$625,600 determined in the deficiency notice). When \$584,035.44 is multiplied by the factor .46002, pursuant to Regulations 108, section 86.19(g), Table A, Column 3 (reversion

---

<sup>2</sup> Internal Revenue Code of 1939.

Sec. 1002. Transfer for Less than Adequate and Full Consideration.

Where property is transferred for less than an adequate and full consideration in money or money's worth, then the amount by which the value of the property exceeded the value of the consideration shall, for the purpose of the tax imposed by this chapter, be deemed a gift, and shall be included in computing the amount of gifts made during the calendar year.

after life estate in 48-year old person), a figure of \$268,667.98 (instead of the \$287,788.51 in the deficiency notice) is arrived at for the value of the remainder. Respondent now maintains that petitioner made a taxable gift in 1950 in the amount of that \$268,667.98, instead of \$287,788.51 as determined in the deficiency notice.

Petitioner, on the other hand, argues that she made no gift because the transaction was without donative intent and was solely motivated by consideration of her own economic advantage and that, in any event, she received "adequate and full consideration in money or money's worth" for the remainder interest which, as a result of her election, was transferred to Irving's trust for her son's benefit.

We have recently enunciated the basic principles applicable to situations of this type in *Chase National Bank*, 25 T.C. 617. It is clear from a reading of that case that petitioner must be considered as having made a gift to the extent that the value of the interest she surrendered in her share of the community property exceeded the value of the interest she thereby acquired under the terms of Irving's will. If petitioner received more than she surrendered then, of course, no gift has been made. Our task, therefore, is to determine the value of what she received for what she gave up. In the *Chase National Bank* case, *supra*, we laid down the rule for measuring the value of the gift of the remainder interest in the testamentary trust there involved, as follows:

We therefore hold that Marie's acquiescence in this trust constituted a taxable gift to the extent of her community one-half of the principal less the life estate reserved by her therein, reduced by the value of the life estate received by her in the other one-half of the trust as consideration.

The same rule should be applied here in a computation under Rule 50, except that in the instant case petitioner received an outright bequest of \$35,000 under decedent's will. That \$35,000 should be added as a portion of what petitioner received for what she gave up.

In fixing the valuation of decedent's one-half interest in the community property which went into the testamentary trust and in fixing the value of petitioner's one-half interest in the community property which went into the testamentary trust, the parties have entered into an extensive stipulation concerning these matters. Only one item in the matter of valuation remains to be decided. This question is whether the petitioner's legacy under the will in the amount of \$35,000 should be considered as a bequest of decedent's one-half of the community property and, accordingly, not subtracted from the value of petitioner's community interest, as the respondent contends, or whether it should be considered as applied in toto against the petitioner's share of the community property and thus reduce by \$35,000 the value of what the petitioner contributed to the trust, as the petitioner contends.

We have decided this difference between the parties in accordance with respondent's contention. Accordingly, in our Findings of Fact we have reduced decedent's share of the community property which otherwise would have gone into the testamentary trust by this \$35,000. It seems clear to us from this provision in decedent's will that he realized that if Mildred took under the will she would not receive any lump sum payment in cash and it was his desire that this \$35,000 should be paid to her in order that she could give a like amount to her relatives, as he was bequeathing to his relatives, or, if she preferred, she could use the \$35,000 in any manner that she desired. So it seems to us that when all the provisions of the will are considered it is reasonable to conclude that decedent intended that this \$35,000 should be paid out of his share of the community property and we have so treated it in our Findings of Fact. However, it also seems equally clear that this \$35,000 became a part of what petitioner received for what she gave up when she elected to take under decedent's will. To add this \$35,000 to what petitioner received does no violence to the rule used in Chase National Bank, *supra*, in valuing the amount of the gift. It simply adds another factor, which was not present in that case, to be used in determining the value of the gift.

There is another issue which petitioner raises which we think we must discuss and that is the effect of that provision in decedent's will which reads as follows:

Seven: \* \* \*

(a) To pay to my beloved wife, Mildred Irene Siegel, for the support, maintenance and care of herself and our beloved son, Richard Bruce Siegel, such sum as in the sole discretion of the majority of said trustees they deem proper to maintain at least the same standard of living to which she has been accustomed in recent years, but in no event less than the sum of One Thousand (\$1,000.00) Dollars per month;

Petitioner in effect argues that this provision in the will was tantamount to giving petitioner an annuity at least large enough to maintain the standard of living which she enjoyed in the recent years prior to decedent's death, which she contends was not less than \$46,000 annually, and that this right should be valued as was done in *Estate of Sarah A. Bergan*, 1 T.C. 543, and that when this is done, the rights which petitioner received under the terms of the testamentary trust are considerably in excess of the remainder interest in her share of the community property which went to her son under the terms of the trust. Hence petitioner contends there was no gift because she received considerably more than she gave up.

We are not persuaded by this argument. True, in our Findings of Fact we have a finding based on the evidence which says:

Under the economic conditions existing during the years subsequent to decedent's death and prior to this hearing it would cost petitioner \$45,000 per year, including income taxes, to maintain the



standard of living to which she was accustomed in recent years prior to decedent's death.

But we do not think this finding helps petitioner. Under the terms of paragraph Seven of the will, what was to be paid to petitioner was "such sum as in the sole discretion of the majority of said trustees they deem proper to maintain at least the same standard of living to which she has been accustomed in recent years, but in no event less than the sum of One Thousand (\$1,000.00) Dollars per month," (emphasis supplied). We do not think it would be possible to construe this provision in the will as spelling out an annuity such as petitioner claims. The large income of the trust seems to us to make very improbable the invasion of principal in order to provide the minimum payments of \$1,000 a month. Hence, it seems to us that we would not be justified in adding the value of the right of petitioner to have the principal invaded as one of the things which she received for what she gave up.

In Chase National Bank, *supra*, in the testamentary trust there involved, the trustee was given a broad discretionary power to distribute principal to any beneficiary. It was requested to exercise such discretion liberally but its decision was made final and conclusive. In that case we said:

In determining the value of the gift made by Marie in respect of the Testamentary Trust we have not ignored the provision conferring upon the trustee the discretionary power to distribute principal. This power is one which the trustee has the

right to use or not to use, as it wishes, but it does not represent anything given to or received by Marie that is capable of valuation. \* \* \* The amount of the taxable gift may not be reduced by reason of a possibility, over which Marie had no control and which is incapable of valuation, that the corpus or a part of it might be paid over to her. Cf. *Robinette vs. Helvering*, 318 U.S. 184, 188-189.

We think we must so hold in the instant case. While there is some difference in the power of the trustees in the instant case to invade the corpus for purpose of making payments to petitioner from the power which was given the trustee to invade the corpus in the *Chase National Bank*, *supra*, we think we would be unable to spell out a valid distinction between the two cases. We hold against petitioner on this issue.

Decision will be entered under Rule 50.

---

Tax Court of the United States  
Washington

Docket No. 52700

MILDRED IRENE SIEGEL,      Petitioner,

vs.

COMMISSIONER OF INTERNAL REVENUE,  
Respondent.

DECISION

Pursuant to the Findings of Fact and Opinion of the Court filed June 29, 1956, the parties herein

on October 2, 1956, having filed an agreed computation of the tax, now therefore, it is

Ordered and Decided: that there is a deficiency in gift tax for the year 1950 in the amount of \$4,314.87.

[Seal]           /s/ EUGENE BLACK,  
  Judge

Entered October 3, 1956.

---

In the United States Court of Appeals  
for the Ninth Circuit

T. C. Docket No. 52700

COMMISSIONER OF INTERNAL REVENUE,  
Petitioner on Review,

vs.

MILDRED IRENE SIEGEL,  
Respondent on Review.

PETITION FOR REVIEW

To the Honorable Judge of the United States Court  
of Appeals for the Ninth Circuit:

The Commissioner of Internal Revenue hereby petitions the United States Court of Appeals for the Ninth Circuit to review the decision entered by The Tax Court of the United States on October 3, 1956, ordering and deciding that there is a deficiency in gift tax for the year 1950 in the amount of \$4,314.87. This petition for review is filed pursuant

to the provisions of sections 7482 and 7483 of the Internal Revenue Code of 1954.

The respondent on review (hereinafter referred to as the taxpayer) resides at 406 South June Street, Los Angeles, California. The taxpayer filed her gift tax return for the year 1950 with the Collector of Internal Revenue at Los Angeles, California, and within the judicial circuit of the United States Court of Appeals for the Ninth Circuit, wherein this review is sought.

#### Nature of Controversy

The question involved is that since the Tax Court held that taxpayer's election to take under the terms of her deceased husband's will constituted a gift by her of her one-half of the community property, should the amount of such gift be measured by her community one-half reduced only by the present value of the life estate that she retained therein, or should it be further reduced by the present value of her life estate in the husband's one-half of the community and a specific bequest granted her by the terms of the will?

Taxpayer's husband's will purportedly disposed of the entire community property even though under the laws of California one-half of such was the absolute property of the taxpayer. The taxpayer elected to take under the will of her deceased husband, which necessitated a transfer to the trust created by the will of her interest in property which had been the community property of herself and her deceased husband. The will provided that tax-

payer's interest in the trust was the right to receive the income for life, and her son was to be the remainderman of the trust corpus consisting of the entire community estate. The Commissioner took the position that the gift consisted of the value of taxpayer's one-half interest in the community estate less the value of a life estate in one-half of the community estate.

/s/ CHARLES K. RICE,  
Assistant Attorney General

/s/ JOHN POTTS BARNES,  
Chief Counsel, Internal Revenue Service, Counsel  
for Petitioner on Review

[Endorsed]: T.C.U.S. Filed December 20, 1956.

---

[Title of U. S. Court of Appeals and Cause.]

NOTICE OF FILING PETITION FOR  
REVIEW

To: Dana Latham, Esq., c/o Latham & Watkins,  
Suite 830, Statler Center, Los Angeles 17,  
California.

You are hereby notified that the Commissioner of Internal Revenue did, on the 20th day of December, 1956, file with the Clerk of The Tax Court of the United States, at Washington, D. C., a petition for review by the United States Court of Appeals for the Ninth Circuit of the decision of the Tax Court heretofore rendered in the above-entitled

cause. A copy of the petition for review as filed is hereto attached and served upon you.

Dated this 20th day of December, 1956.

/s/ JOHN POTTS BARNES,  
Chief Counsel, Internal Revenue Service, Counsel  
for Petitioner on Review

Acknowledgment of Service attached.

[Endorsed]: T.C.U.S. Filed January 3, 1957.

---

[Title of U. S. Court of Appeals and Cause.]

NOTICE OF FILING PETITION  
FOR REVIEW

To: Mildred Irene Siegel, 406 South June Street,  
Los Angeles, California.

You are hereby notified that the Commissioner of Internal Revenue did, on the 20th day of December, 1956, file with the Clerk of The Tax Court of the United States, at Washington, D. C., a petition for review by the United States Court of Appeals for the Ninth Circuit of the decision of the Tax Court heretofore rendered in the above-entitled cause. A copy of the petition for review as filed is hereto attached and served upon you.

Dated this 20th day of December, 1956.

/s/ JOHN POTTS BARNES,  
Chief Counsel, Internal Revenue Service, Counsel  
for Petitioner on Review

Acknowledgment of Service attached.

[Endorsed]: T.C.U.S. Filed January 3, 1957.

[Title of U. S. Court of Appeals and Cause.]

STATEMENT OF POINTS

Comes Now the petitioner on review herein and makes this concise statement of points on which he intends to rely on the review herein, to-wit:

The Tax Court of the United States erred:

1. In holding that the amount of the gift should be measured by taxpayer's community one-half reduced by the present value of her life interest in the husband's one-half of the community and a specific bequest granted to her by the terms of the will.

2. In failing to hold that the amount of the gift should be measured by taxpayer's community one-half reduced only by the present value of the life estate that she retained therein.

3. In holding that there is a deficiency in gift tax for the year 1950 in the amount of \$4,314.87.

4. In failing to hold that there is a deficiency in gift tax for the year 1950 in the amount of \$51,144.24.

5. In that its opinion and decision are contrary to law and regulations and are not supported by its finding of fact or substantial evidence.

/s/ CHARLES K. RICE,

Assistant Attorney General

/s/ HERMAN T. REILING,

Acting Chief Counsel, Internal Revenue Service,  
Counsel for Petitioner on Review

Acknowledgment of Service Attached.

[Endorsed]: T.C.U.S. Filed January 23, 1957.

[Title of U. S. Court of Appeals and Cause.]

DESIGNATION OF RECORD

To the Clerk of The Tax Court of the United States:

You will please prepare, transmit and deliver to the Clerk of the United States Court of Appeals for the Ninth Circuit the following documents and records in the above-entitled cause, in connection with the petition for review by the said Court of Appeals heretofore filed by the Commissioner of Internal Revenue:

1. Docket entries.
2. Pleadings: (a) Petition, including notice of deficiency, (b) Answer.
3. Opinion and decision of the Tax Court.
4. Stipulation of facts, with Exhibit 1-A attached.
5. Transcript of hearing at Los Angeles, California, on June 20, 1955.
6. All exhibits.
7. Petition for review and proofs of service.
8. Statement of points.
9. This designation.
10. Order extending time to file record on review.

/s/ CHARLES K. RICE,  
Assistant Attorney General

/s/ HERMAN T. REILING,  
Acting Chief Counsel, Internal Revenue Service,  
Attorneys for Petitioner on Review  
Acknowledgment of Service Attached.

[Endorsed]: T.C.U.S. Filed January 23, 1957.



Tax Court of the United States

[Title of Cause No. 52700.]

ORDER ENLARGING TIME

Upon consideration of motion of counsel for petitioner on review, it is

Ordered: That the time for filing the record on review and docketing the petition for review in the United States Court of Appeals for the Ninth Circuit is extended to March 20, 1957.

Dated: Washington, D. C., January 16, 1957.

[Seal]        /s/ J. E. MURDOCK,

Entered January 17, 1957.

---

The Tax Court of the United States  
Washington

[Title of Cause No. 52700.]

CERTIFICATE

I, Howard P. Locke, Clerk of the Tax Court of the United States, do hereby certify that the foregoing documents 1 to 14, inclusive, constitute and are all of the original papers on file in my office as called for by the "Designation of Contents of Record on Review", including Joint Exhibit 1-A attached to the Stipulation of Facts and Petitioner's Exhibits 2 through 8, admitted in evidence, in the case before the Tax Court of the United States docketed at the above number, and in which the Re-

spondent in the Tax Court has initiated an appeal as above numbered and entitled, together with a true copy of the docket entries in said Tax Court case, as the same appear in the official docket book in my office.

In testimony whereof, I hereunto set my hand and affix the seal of the Tax Court of the United States, at Washington, in the District of Columbia, this 7th day of February, 1957.

[Seal]            /s/ HOWARD P. LOCKE,  
                         Clerk, The Tax Court of the  
                         United States

---

In the Tax Court of the United States

Docket No. 52700

MILDRED IRENE SIEGEL,            Petitioner,

vs.

COMMISSIONER OF INTERNAL REVENUE,  
                         Respondent.

TRANSCRIPT OF PROCEEDINGS

Courtroom No. 9, U. S. Post Office, Los Angeles, California, Monday, June 20, 1955.

The above-entitled matter came on for hearing, pursuant to notice to the parties, at 2:00 o'clock p.m.

Before: Honorable Eugene Black, J., presiding.

Appearances: Latham & Watkins, by Dana Latham, and Grover Heyler, 830 Statler Center, 900

Wilshire Blvd., Los Angeles, Calif., for the Petitioner. John J. Burke (Hon. Daniel A. Taylor, Chief Counsel, Internal Revenue Service) for the Respondent. [1\*]

The Court: The Clerk will call the case that we have set at this time.

The Clerk: Docket No. 52700, Mildred Irene Siegel.

Mr. Latham: Petitioner is ready.

Mr. Burke: Respondent is ready, Your Honor. John J. Burke for the respondent.

Mr. Latham: Grover Heyler and Dana Latham for the petitioner.

The Court: Yes, Mr. Latham, you may make your opening statement at this time.

Mr. Latham: Your Honor, this is a gift tax case involving the year 1950, with approximately \$51,-000 of tax involved, all of which is in controversy. I think that, in order to explain the issues, it will be better to make a brief statement of all of the facts involved.

The Court: Yes, you may do that.

Mr. Latham: The petitioner's husband, Irving Siegel, died on January 4, 1949, a resident of Los Angeles, and all his estate at the time of his death was admittedly community property under the laws of the State of California, and further they were married here after 1927.

His will, which was dated March 31, 1948, purported to dispose of the entire community property,

---

\* Page numbers appearing at top of page of original Reporter's Transcript of Record.

and required the widow, the petitioner in this proceeding, to elect to either [3] take under the will or against it. Now, if she elected to take against the will, she received only her one-half of the community property, reduced by appropriate administration expenses. If she took under the will, she received the following, according to the will's terms:

The home and its furnishings. As a matter of fact, those items were in joint tenancy at the time of death, so they can be ignored for the purpose of this proceeding.

She received under the will his personal effects, his automobiles, and \$35,000 in cash, and an interest for life in the income of a testamentary trust created under the will and which consisted of the entire residue of the estate. In that particular, the will provides—and I might add that these items are all attached as exhibits to the stipulation which will be submitted—the will provided that, with respect to this trust, Mrs. Siegel, the petitioner, should receive for the support, maintenance and care of herself and “our beloved son, Richard Bruce Siegel,” sums such as in the sole discretion of the majority of the trustees they deem proper to maintain at least the same standard of living to which she had been accustomed in recent years, but in no event, less than the sum of \$1,000 per month.

The will also provided that, “In the event the net income from the trust estate is not sufficient to make the payments above provided, then and in that event I specifically [4] authorize my trustees to make payments from the corpus of said trust

estate to the extent necessary to provide for the payments as set forth above.”

Now, under the will, it also provides that after the widow's life estate in the entire trust, the remainder interest went to the minor son of the decedent and the petitioner.

On January 5, 1950, approximately a year after Mr. Siegel's death, Mrs. Siegel, the petitioner, elected in writing to take under the will. Now, the respondent fixed what he believed to be the value of the petitioner's one-half interest in the community property at the date she exercised her election, January 5, 1950, and on an actuarial basis, the respondent then determined the value of the remainder interest in this half of the community. He allowed \$30,000 statutory exemption but no exclusion, and asserted the gift tax that is here in controversy.

The respondent gave no consideration nor allowance to or for the fact that the petitioner acquired an interest for life in her husband's half of the community property, and that is the basis for the controversy.

Now, the petitioner contends, first, that in the exercise of this right to take under the will, as opposed to against it, there was no donative intent. Instead, she made a deliberate choice, then, to give up the remainder interest in her one-half in exchange for a life estate, not only in her [5] half, which she retained, of course, but in her husband's one-half.

Now, accordingly, this should be no gift even if, on an actuarial basis, the value of the remainder

was slightly in excess of the commuted value of the interest which she acquired in her husband's half, in other words, where you have an arm's length dealing, no taxable gift can accrue merely because one party to the transaction apparently gets a little less in actuarial dollars than the other.

The petitioner's second contention is that even if she made a taxable gift or a gift, something she certainly never intended to do, she never thought about it, that in no event could the value of that gift exceed the difference between the value of her life estate and her husband's one-half of community, and the value of the remainder interest in her one-half, which the son acquired by virtue of the exercise of her election. There should be an offset, in any event, at the worst.

Now, finally, we contend that as a matter of fact the value of this gift can't be determined in this year 1950, because the decedent's estate is not closed, and the exact amount of the property which passes to the testamentary trust has not yet been determined, and it won't be determined until the executors of the estate actually pay it over to the testamentary trust. [6]

Now, here we only had a partial distribution to the trust in the year 1950. The respondent apparently is not basing his claim for a gift tax on the fact of distribution, but on the fact that an election was made at a certain time, and as a result of that election, and on that date, the respondent undertook to determine values on said date of the election, and then he reduced the amount by certain

charges and payments that were made; as a matter of fact, some of them weren't even determined until years after 1950.

So that, regardless of every other consideration, even if we were wrong on every other contention, the gift should not exceed the proper value of the property, actually paid into the testamentary trust in the year 1950.

Now, there are certain minor differences between petitioner and the respondent as to the treatment to be accorded certain amounts that were received by petitioner and expenses paid during probate.

With respect to some of these, the petitioner contends that her half of the community should be reduced by some of these charges, with respect to others we contend that the charge should be apportioned between the decedent's half of the community and her half.

Now, with respect to those items, the respondent disagrees. We will have no evidence with respect to those points; instead, they will be embodied in the stipulation of facts, [7] and the law applicable can be argued in our briefs.

We don't undertake to state for the respondent his views, but as we understand them I think these are they:

Of course, Mr. Burke will correct me as he sees fit.

First, as I understand it, the respondent contends that, in exercising her election, she never intended to bargain, but instead she intended to make

a gift of the remainder interest to her son, and therefore they ignore completely the interest which she acquired in her husband's half of the community.

The evidence which we will introduce, I think, will show that the exact opposite was true.

Secondly, as we understand it, the petitioner—the respondent contends that, even if petitioner did bargain, that she cannot offset against the value of this remainder interest, anything for the interest in her husband's half of the community, and I think, assuming they make that contention, that they base that on two contentions, 1, that she did not receive a full right, that is, indivisible right to the income, but only such amounts as the trust deeds chose to give her; and, second, that her son also received an enforceable right in this income from her husband's half of the estate.

Now, assuming that those are the contentions of the respondent, we answer them this way: In the first place, the petitioner was entitled under the specific terms of the will to [8] receive such amounts as would enable her to maintain, and I quote, "at least the same standard of living to which she had been accustomed at the date of her husband's death."

Now, the evidence which we will introduce will show that this standard of living required the payment to her of more than the entire actuarial income from the entire trust estate.

Further, the evidence will show that the trust deeds did, in fact, since Mr. Siegel's death, pay



her such amounts in conformity with the provisions of the will, and that such amounts were in excess of the actuarial value of the entire estate.

Therefore, there was no question but what she was entitled to the entire interest, and the trustees, the discretion in the trustees, instead of limiting or reducing her rights, really increased them, because the trustees were required under the will to pay her, not only such income as was necessary to maintain the standard of living, but they were required to invade corpus if the income was insufficient.

With respect to the son, and the interest if any that he acquired in this life income, we contend, first, that it is obvious from the examination of the will that it was never intended that the son acquire any enforceable interest in the trust income, and the decedent, in referring to the son, was merely referring to petitioner's general obligation to support [9] her minor child.

The payments are to be made to her, and the standard of living to be maintained is hers and hers alone.

Second, since the payments made to her have exceeded the entire actuarial income, there was nothing left for the son, in any event.

Finally, even if the son did acquire some interest, at the most, it would merely slightly reduce the value of the petitioner's life income in the husband's half of the community property.

Now, the evidence which will be introduced will

consist of a written statement of facts submitted as a joint exhibit, and certain oral testimony.

That concludes our statement.

The Court: All right, Mr. Latham.

Mr. Burke?

Mr. Burke: If the Court please, some of the comments I am going to make are going to be repetitious, since Mr. Latham did cover the facts very extensively.

As he has pointed out, when the petitioner's husband died, he was possessed of property which was the community property of the decedent and the widow, the petitioner herein.

Now, the decedent's will purported to dispose of all of the community property, providing that the widow, the [10] petitioner, elect under the will to take the interest the will gave her in lieu of her one-half interest in all of the community property, which vested in her upon the death of decedent.

As Mr. Latham has pointed out, there were specific bequests to the widow, to others, with the residue of this property going into the trust, providing for the income to be paid to petitioner during her life for support, and the support of her adopted son, their adopted son, with the remainder interest in the son.

Now, the will provided that if the widow elected to take her community share of the property, it should go, as it was provided therein, but if she elected to take the community property share, rather than her interest under the will, then the

provisions of the will in her favor were to become inoperative.

However, it doesn't clearly spell out the alternative disposition of the property.

As Mr. Latham pointed out, the decedent died in January, 1949, and the widow exercised her election on January 5, 1950.

As I said before, under the California community property law, on the death of the decedent, his widow held a vested one-half interest in all the property which had been the community property of herself and the deceased husband. [11]

However, inasmuch as this entire community is subject to probate, and subject to the debts of the decedent, the expenses of administration, such interest of the widow in the property was subject to one-half of all such debts and expenses.

We have generally agreed on all these amounts, as is evidenced in our stipulation.

I therefore think that if we have a transfer, if the Court is to determine that we have a transfer, we very definitely can value this transfer, because we have all of the elements which go into the value of such transfer. We have the gross amount of the value of each in the community property. We have the expenses and debts up to the time of the date of transfer, and we have the subsequent expenses and debts, if any, subsequent to the date of the transfer.

Now, it was my understanding, when we stipulated, that we would use those figures in computing any such value, if the Court determines in accord-

ance with our position that there was a transfer of this interest. Mr. Latham said that the value can't be determined as of January 5, 1950. Maybe I might have to have some additional explanation on that point. I thought his alternative position was that, if the Court doesn't determine there was a transfer of her entire interest as of January 5, 1950, that all she transferred as of that date was the amount actually distributed from the estate to the trust in 1950, an amount which we have agreed upon, we [12] could perhaps leave that open now and discuss it on brief. I am not sure whether we have disagreement of the facts.

Mr. Latham: If I may, just to clarify that, the various expenses, if your Honor please, that were paid after the distribution into the trust in 1950, we are not contending that those expenses should be charged against the distribution made in 1950. In other words, the amount that was actually distributed in the trust in 1950 is in the stipulation of facts.

Mr. Burke: That is right.

Mr. Latham: So there isn't any question of proportionment. Does that clarify——

Mr. Burke: I think I understand what you mean now. I misunderstood your statement, your opening statement.

To go on, then, when the petitioner made her election to take under the will, she gave up, in effect, her remainder interest in the one-half interest in the entire community property.

Now, the Commissioner has determined that, by

virtue of this election, the petitioner effected as of the date of the election the transfer of this interest, and inasmuch as the transfer was to an irrevocable testamentary trust, there was a completed irrevocable transfer of the entire remainder interest in her community share.

Accordingly, the value of the remainder as of January 5, 1950—and this amount we determined—is subject to [13] Federal gift tax.

Now, as I understand the petitioner's case, she has raised two major points. The first of these is that any such transfer as she may have made of her remainder interest was made in exchange for full and adequate consideration, so that there is no taxable gift, although I noticed that Mr. Latham didn't use those terminologies; I understand that it would mean the same thing. He referred to no donative intent.

Mr. Latham: I would be glad to use that, if you want me to. That is the way I feel.

Mr. Burke: Or that, in the alternative, it appears their argument was that there was some consideration flowing to the petitioner, by virtue of which she took under the will, which would reduce the amount subject to the gift tax.

The other point which we have just discussed is that the petitioner in the year 1950 transferred her one-half interest totaling \$325,815.17 in the real property and the personal property, distributed to the trust from the estate in that year.

Now, in considering the question whether or not consideration, in fact, was given in exchange for

any transfer made by the petitioner, the primary question, as we see it, is what is meant by the term "consideration" as applied in Section 1002 of the Internal Revenue Code of 1939.

That states that when the property is transferred for [14] less than adequate and full consideration in money or money's worth, the amount by which the value of the property exceeded the value of the consideration shall be included in computing the amount of the gifts made.

As we see it, there are several interpretations which might be presented to this Court, for its determination as to what is meant by the term "consideration," as used in this section of the Code.

First of all, it could mean consideration flowing only from the donee, which would be the son in this case, to the donor.

Another interpretation to be placed on the term is that it refers only to legal consideration in the contractual sense, which would include third party beneficiary types of contracts.

In the instant case, there is clearly no consideration flowing to the petitioner from her son in consideration of the transfer. We need not go into that matter any further.

With respect to the consideration in a legal sense, it is also clear from the facts in our stipulation that no legal obligation arising out of any contract, either expressed or implied, existed by virtue of which the petitioner derived consideration in any form in exchange for her transfer. She was not bound to make this election.

Absent the existence of any contractual agreement [15] between the parties, there is no basis for any application of or inquiry into the matter of consideration, as the respondent contends. It is our position that if the petitioner is to prevail in her position in this respect, that the Court may even consider what she received under the will, there must be evolved a more generic concept of the term "consideration" to cover the facts in this case.

Now, in that respect, we believe that there is a very compelling and sound reason why the Court should not adopt any such theory. The basic legislative intent in the enactment of the Federal estate and gift tax law was to tax both the transfers devolving by operation of death and inter vivos transfers.

We contend that this basic legislative purpose would be perverted if this Court were to hold that the gift herein should be in any way reduced, as a result of any interest which the widow took under the will.

Analyzing this in more detail, it appears that what occurred here actually were three transfers:

In disposing of his one-half interest in the community, the only interest which he had an absolute right to transfer, the decedent made two transfers. He transferred a life interest in his wife, or in his wife and son, and a transfer of a remainder to the son. This is the type of transfer which the Federal estate tax legislation was enacted to tax. By [16] taxing all of the profit, we tax both of these transfers, since the net value of the estate represents

both the life interest and the remainder interest.

Now, going back to the interest which the petitioner had, this vested in her, as of the death of the decedent—this is just basic community property law. Now, at all times she held her entire one-half interest in the property and was free to dispose of such interest as she saw fit.

When she elected to take under the will, she of course retained her life interest in her one-half, and she transferred to an irrevocable testamentary trust a remainder interest in her one-half interest in the community property to her son.

Here was the third transfer, the transfer of the remainder interest, and this is the type of transfer that the Federal gift tax law was designed to tax.

We have, then, under our theory of the case all three transfers taxed in accordance with the over-all Congressional intent. If we were now to turn about and use the transfer from the husband to the wife of his one-half interest in the community as an offset, we would be effectually eliminating the tax on one of the three transfers by offsetting the transfer to the son, by the transfer from the decedent. The effect would be to tax, not what I have referred to as three transfers herein, but only two. There might, of course, be some possible [17] differences in rates, but the principle would remain the same. Any such decision by the Court would have the effect of eliminating a tax on one of these transfers.

It is accordingly our principal contention that no such approach should be taken by this Court,



and no such interpretation should be given to the term "consideration" as would have this effect in operation.

Now, if this Court were to reject our principal contention and hold that there is consideration here, then it is our principal contention, and I believe that Mr. Latham has stated that when he speaks of an interest which the widow received, he refers only to a one-half interest, which is the interest from the decedent—you are not, as I understand, maintaining that the consideration was an entire life interest in all of the community?

Mr. Latham: She already had that.

Mr. Burke: I misunderstood your position.

So that our only position with respect to that life, our only issue with respect to that life interest, as I see it, only real issue, is the question of whether or not the widow received the entire one-half interest in the decedent's community property—property, or whether or not there was an interest also in her son.

Now, as Mr. Latham has stated, Paragraph 7 of the will provides that the income is to be paid to the widow for [18] her support and the support of her son. We contend that, in the absence of any other evidence to the contrary, a proper interpretation of this clause of the will requires a recognition that there is at least an interest created in the son to the extent of such income as is necessary to support and maintain him.

It has been argued under similar family purpose trusts that the parent and the child take equal

shares. I would like at this time to reserve the right, after further examining the case law in this respect, to argue either way on this point. Now, coming to the next main issue, as presented by Mr. Latham, it appears that it is his position that if there is a gift in 1950, in the alternative, that gift is the amount which was actually distributed by the estate in 1950 to the trust.

Now, under our approach, we feel that it should be argued, the Court should adopt the position that if there was a transfer, it is a transfer by virtue of this election, that as of the date of that election, the transfer took place. Therefore, the petitioner no longer had any control of any kind whatsoever over the property. So that it makes no difference whether a partial distribution or a total distribution was made in 1950 or at any other time.

The point is that the value must be placed on what [19] she transferred by virtue of her election, and it does not follow that the time of the distribution or the date of the distribution—the time of the distribution or the amount of the distribution has any effect whatsoever on the ultimate determination.

Now, the remaining issue, as we see it, is the question of whether a specific bequest of \$35,000 made by the decedent to the widow in Paragraph 3 of the will is an amount which should be charged against his community share or the community property of both, that is, whether \$35,000 should come out of his one-half interest or one-half of such amount be charged to the interest of him and

the interest of the widow. We believe this is basically a question of interpretation of the will, and we will argue on brief why we believe that our interpretation under the terms of the will indicate and require a conclusion that that was a bequest coming out of the decedent's one-half share in the community.

Mr. Latham has suggested that we are arguing strongly that inasmuch as the trust is discretionary, it is one for support and maintenance, that the value which the petitioner received was substantially less for that reason. In other words, their interest would be diminished by what was needed for her support and maintenance, I mean the value of the difference between what was received and what was needed for her support and maintenance. We have no evidence with respect to these [20] items, and we have no real basis, I believe, for contention on that point. I can see none.

I think we have everything in the stipulation, your Honor, which is necessary in any computation the Court might have to make, whichever of the theories, either the petitioner's or the respondent's, you ultimately determine is correct.

The Court: Are you ready to present the stipulation?

Mr. Latham: It will be a joint stipulation.

The Court: The stipulation of facts is received in evidence. I suppose there are some exhibits?

Mr. Latham: Just one, your Honor, the will.

The Court: The stipulation is received, together with the exhibit that is attached.

Now, Mr. Latham, we are ready to receive the evidence.

(The documents above referred to were marked for identification as Joint Exhibit 1 and received in evidence.)

[See pages 18-29.]

Mr. Latham: I might add one thing.

The Court: All right, you may.

Mr. Latham: I was interested in Mr. Burke's statement that, to take the position urged by petitioner here would subvert the taxing laws with respect to transfers. It is rather interesting for this reason:

As a matter of common knowledge, I suppose 90 per cent of the wills in California are exactly like this, where the widow, where the widow takes an election, where community property is concerned. And to my knowledge, as a practitioner here for many years, this is the first time that the question [21] of a taxable gift in connection with the exercise of an election has ever been raised. Certainly, there are no court cases on it. It is just a matter of interest that I think——

Mr. Burke: Your Honor, Mr. Latham is correct, with respect to the problem as far as case law is concerned. However, the only authority I have is hearsay, but I have discussed this matter with the head man, as far as the Director's office is concerned, in this type of an arrangement, and he has assured me that this type of arrangement has been held by his office to be a gift and has been taxed, so I have only his statement on that.

Mr. Latham: We have been very fortunate, I guess, in our office.

Mrs. Siegel, will you take the stand.

Whereupon,

MILDRED IRENE SIEGEL

called as a witness for and on behalf of herself, Petitioner, having been first duly sworn, was examined and testified as follows:

Direct Examination

Q. (By Mr. Latham): Will you state your name, please? A. Mildred Irene Siegel.

Q. Where do you live?

A. 3278 Wilshire Boulevard. [22]

Q. How long have you lived in that location?

A. Since April 1.

Q. This year? A. Yes.

Q. You are the petitioner in this proceeding before the Tax Court? A. Yes.

Q. You are the widow of the late Irving Siegel?

A. Yes, I am.

Q. When did he pass away?

A. December—January 4, 1949.

Q. What was the cause of his death?

A. Coronary thrombosis.

Q. Was it sudden and unexpected?

A. Yes.

Q. How old was he when he passed away?

A. 47.

Q. And his business at the time of his death?

A. Builder and contractor.

Q. In Los Angeles? A. Yes.

(Testimony of Mildred Irene Siegel.)

Q. How long had he been engaged in that business? A. Oh, for 25 or 30 years.

Q. How long had you been married to Mr. Siegel at the time of his death? [23]

A. 27 years.

Q. Did you reside in California during the entire period of your marriage?

A. All but four years.

Q. Did either of you have any separate property of consequence at the time of your marriage?

A. No.

Q. Either of you acquire any property by gift or inheritance from any third person during the marriage? A. No.

Q. Where did you live at the time of Mr. Siegel's death?

A. 406 South June Street.

Q. Los Angeles? A. Los Angeles.

Q. How long had you resided there?

A. A little over a year.

Q. Do you recall the cost of that home?

A. \$62,500.

Q. Were alterations and additions made to the property after you acquired it? A. Yes.

Q. Can you estimate the cost of those additions?

A. I would say around \$30,000.

Q. Did the figures you gave me include the cost of the furnishings installed in that residence? [24]

A. No.

Q. Can you estimate the cost of the furnishings installed in that residence?

(Testimony of Mildred Irene Siegel.)

A. Well, the appraised value in 1950 was, the replacement value was \$60,000.

Q. You were living in that home, then, on March 31, 1948, the date of Mr. Siegel's will?

A. Yes, sir.

Q. Did you do any entertaining of consequence in your June Street home?

A. Yes, very great deal.

Q. How many in household help did you maintain there at the time of Mr. Siegel's death?

A. We had two people.

Q. Inside help?           A. Yes.

Q. Did you also have a gardener who maintained the premises?

A. Yes, we did.

Q. Did you have any other home at the time of Mr. Siegel's death?

A. Yes, I owned a house in Palm Springs.

Q. You or both of you?

A. Both of us.

Q. When was that residence acquired? [25]

A. Four years before Mr. Siegel passed away.

It would be 1945.

Q. You recall what the Palm Springs residence cost?           A. No, I don't.

Q. How many rooms did the Palm Springs home contain?

A. Six rooms and three baths.

Q. Was that house completely furnished?

A. Yes, it was.

(Testimony of Mildred Irene Siegel.)

Q. How many automobiles did you and Mr. Siegel own at the time of his death?

A. Two.

Q. Do you recall the make of the cars?

A. Yes, they were Cadillacs.

Mr. Latham: Now, it will be stipulated, I believe, for the record that for the calendar year 1947 Mr. and Mrs. Siegel's net income for Federal income tax purposes was \$479,422.99, and for the year 1948, \$230,300.99. All of the said community was community income. Is that satisfactory?

Mr. Burke: That is correct.

Q. (By Mr. Latham): Do you know approximately how much it cost you and Mr. Siegel to live, excluding income taxes, for the year 1948, the last full year of his death?

A. I don't know, excluding. I know including it was between \$45,000 and \$50,000. [26]

Mr. Latham: I believe these items have been approved by counsel for the respondent. We offer as Petitioner's Exhibit 1—if you are going to call it that, is that appropriate?

The Clerk: 1-A is what you called this.

The Court: 2, probably.

Mr. Latham: Call this Petitioner's Exhibit 2, a statement of the expenses per ledger from January 1, 1948 to December 31, 1948 of Mr. and Mrs. Siegel.

Mr. Burke: We have no objection to the secondary nature of this. In other words, we agree that this may go in as expenditures. However, we do



(Testimony of Mildred Irene Siegel.)

believe that we have an objection with respect to the materiality of this item in determining the issue before the Court. If Mr. Latham would explain the purpose of this exhibit and this line of questioning, I would appreciate it.

Mr. Latham: Yes. We are endeavoring to show the standard of living which was maintained at the time of death, and the cost thereof.

The Court: Yes.

Mr. Latham: In order that we may be certain that there will be no exclusion or determination that the value of her income, of her right to income, his half, was less than the total, which is part of one of our basic contentions in the case.

The Court: Well, I understand the respondent probably will argue in his brief that this is material, whereas the petitioner's contention is that it is a material fact in the case.

Mr. Latham: Highly material.

The Court: The receipt of the evidence, of course, would not preclude that argument at all, and I would overrule the objection. It will be received as Petitioner's Exhibit No. 2.

(The document above referred to was marked for identification as Petitioner's Exhibit No. 2 and received in evidence.)

[See page 95.]

Q. (By Mr. Latham): I will ask you, Mrs. Siegel, please, to examine that, and in your opinion does that statement, which purports to show the expenditures by you and Mr. Siegel for the calendar

(Testimony of Mildred Irene Siegel.)

year 1948, represent in your opinion the amounts necessary to maintain the standard of living in existence at the time of Mr. Siegel's death?

Mr. Burke: I object to that as calling for her opinion. I believe that should be established by Mrs. Siegel's own testimony as to what was her standard, rather than what was her opinion as a result of these expenditures.

The Court: Well, I will overrule the objection. You may answer the question.

A. Yes. [28]

Q. (By Mr. Latham): Did you and Mr. Siegel have any children? A. An adopted boy.

Q. How old is your son now?

A. He is 12.

Q. At the time of Mr. Siegel's death, he was something under six years of age?

A. He was five and a half.

Q. Now, in referring to Mr. Siegel's will, which is Exhibit 1-A to the joint stipulation, I note that Mr. Weingart and Mr. Allison are named as trustees with you. Will you please state briefly the business and social connection between you and Mr. Siegel and these two gentlemen?

A. Well, Mr. Weingart was associated in business, and also a very close friend, and Mr. Allison was a very close friend of Mr. Siegel's.

Q. Approximately how long had you and Mr. Siegel known these two gentlemen prior to Mr. Siegel's death?

(Testimony of Mildred Irene Siegel.)

A. Well, almost as long as we had lived in California, which was in 1926.

Q. In fact, all your married life together?

A. Yes.

Q. And had Mr. and Mrs. Weingart visited in your home and you in theirs?

A. Yes, yes. [29]

Q. Mr. Weingart was familiar with the way you and Mr. Siegel lived? A. Oh, yes.

Q. And was Mr. Allison, also, if you know?

A. No, Mr. Allison was more Mr. Siegel's friend than mine.

Q. Not a social friend? A. No, no.

Q. You know why Mr. Siegel suggested these gentlemen as trustees with you?

A. Well, I guess he thought they were just about the most capable men he knew to administer his estate and to be trustees of the trust.

Q. After Mr. Siegel's death, did you receive the family allowance of his estate? A. Yes, I did.

Q. Do you recall how much it was?

A. It was \$2,000 a month.

Q. And was that amount later changed?

A. Yes, it was raised to three.

Mr. Latham: If Your Honor please, I offer as Petitioner's Exhibit 3, a statement of the cash account of Mildred Siegel for the calendar year 1949, which purports to show all her expenditures and her cash receipts, and subject to Mr. Burke's objection, would like to offer this in evidence [30] as Petitioner's Exhibit 3.

(Testimony of Mildred Irene Siegel.)

Mr. Burke: I would just like the record to show the same objection stands for Exhibit 3 as it did for Exhibit 2.

The Court: Let me see it, Mr. Latham.

Let me understand respondent's objection. Of course, the statement would not prove itself if respondent objects and requires additional evidence as to these items, but if his objection is only as to its materiality, it would be the same as the objection to No. 2.

Mr. Burke: That is correct, Your Honor. In other words, we agree that these amounts were received and expended in this year, and they were for personal——

The Court: As to the correctness, you don't object?

Mr. Burke: That is right.

The Court: What you do object to is their materiality?

Mr. Burke: That is right.

The Court: And on the same ground as stated, for the same reason as stated with reference to Exhibit 2, that objection is overruled without prejudice, of course, for respondent to argue that this is immaterial evidence, which he may do in his brief, of course. The objection is overruled, and it is received as Petitioner's Exhibit No. 3.

(The document above referred to was marked for identification as Petitioner's Exhibit No. 3 and received in evidence.)

[See page 96.] [31]

(Testimony of Mildred Irene Siegel.)

Q. (By Mr. Latham): Mrs. Siegel, showing you Petitioner's Exhibit No. 3, I will ask you if you will examine it, please? A. Yes.

Q. In your opinion, were those expenditures necessary in order for you to maintain the standard of living in effect at the time of Mr. Siegel's death?

A. Yes, sir.

Mr. Latham: I will offer, if Your Honor please, similar statements for the calendar years 1950, '51, '52, '53, and '54, as Petitioner's Exhibits 4, 5, 6, 7, and 8.

The Court: I suppose the respondent's objection is not as to the correctness of these amounts, but as to the materiality of the evidence?

Mr. Burke: Would you allow me to ask Mr. Latham some questions?

The Court: Yes.

(Discussion off the record.)

Mr. Burke: That is correct, Your Honor.

The Court: The objection as to the materiality of the evidence is overruled, and the exhibits are received in evidence as Petitioner's Exhibits Nos. 4, 5, 6, 7, and 8.

(The documents above referred to were marked for identification as Petitioner's Exhibits Nos. 4, 5, 6, 7, and 8 and received in evidence.)

[See pages 97-101.] [32]

Q. (By Mr. Latham): I show you Petitioner's Exhibits 4, 5, 6, 7, and 8, which represent a state-

(Testimony of Mildred Irene Siegel.)

ment of your cash receipts and disbursements for the calendar years 1950 through '54, inclusive.

Did you actually spend those amounts, do you recall, for your living expenses during those years?

A. Yes, sir, I did.

Q. Now, in your opinion, were those amounts necessary, the expenditure of those amounts necessary in order to maintain the standard of living to which you were accustomed at the time of Mr. Siegel's death? A. Yes.

Q. Now, looking into the future a little bit, is it your opinion that substantially these same amounts will be necessary for you to receive in order to maintain this standard of living in the years to come? A. Yes.

Mr. Burke: Same objection to that question, calling for an opinion of the witness, Your Honor.

The Court: The objection is overruled.

Q. (By Mr. Latham): Did you answer the question? A. Yes.

Q. After Mr. Siegel's death, do you recall discussing with the other trustee the amount you should receive from the [33] trust in order to enable you to maintain this standard of living at the date of death? A. Yes.

Q. And was any agreement reached at that time with respect to the amount to be paid you?

A. Yes.

Mr. Latham: If Your Honor please, the stipulation of facts, Joint Exhibit 1, shows that Mrs. Siegel received the following amounts in the following years: 1951, that is—for this testamentary

(Testimony of Mildred Irene Siegel.)

trust, 1951, \$54,000; 1952, \$54,000; 1953, \$52,000; 1954, \$48,000.

Q. (By Mr. Latham): Turning now to consideration of Mr. Siegel's will, did he discuss its terms with you prior to his death?

A. No, he did not.

Q. After he passed away, was the will explained to you?      A. Yes.

Q. How soon, approximately, after he passed away?

A. Oh, I would say a couple of weeks after he passed away.

Q. And who discussed it with you?

A. Mr. Weingart and Mr. Larson, the attorney.

Q. Who is Mr. Larson?

A. My attorney.

Q. He is the attorney— [34]

A. Attorney for the trust.

Q. Did you understand your rights under the will? Was that explained to you?

A. Yes, that was.

Q. What did you understand, what was explained, what did you understand your rights under the will to be?

A. Well, if I took my community half, I was to receive nothing from the other. It would mean that my income would be cut in half, that I would lose.

Q. If you elected to take under the will, what would you get?

A. That I would get the income from the entire estate, from the entire trust.

Q. Did you consider what course of action you

(Testimony of Mildred Irene Siegel.)

should take, so far as your rights under the will were concerned, with anyone?

A. Beg pardon?

Q. Did you consider what course of action to take, discuss it with anyone?

A. Yes, with Mr. Weingart and Mr. Larson and Mr. Allison.

Q. How many times did you discuss it with them prior to the time you exercised the election in writing on January 5, 1950?

A. Oh, many times. [35]

Q. Did you ask Mr. Weingart, your long-time friend, as to what he thought you should do?

A. Yes.

Q. What did he tell you?

A. He told me to take under the will.

Q. Now, in electing to take under the will, did you consider the fact that, among other things, you would have the benefit of the advice of your co-trustees as to investments?

A. Yes, I did.

Q. Did you also consider the fact that, if you took under the will, the entire estate would be under one management instead of being divided in two?      A. Yes.

Q. Why did you elect to take under the will?

A. Because I couldn't maintain my standard of living on the income from my half, and I didn't want to lose control of the other half, and the income.

Q. In electing to take under the will, was it



(Testimony of Mildred Irene Siegel.)

your thought at the time that you would be worse, better off, or about the same as if you took your half?

A. Oh, no, I would be very much better off taking under the will.

Q. You thought you made a good deal?

A. Oh, yes, definitely.

Q. Now, when you were considering what course of action [36] you were to follow, did the possibility that you might be making a gift in electing to take under the will ever occur to you or anyone else?

A. No, it didn't.

Q. Was it ever mentioned by anyone?

A. No.

Q. In exercising your election to take under the will, did you intend to make any kind of a gift?

A. No, I did not.

Q. Now, Mrs. Siegel, what is your best estimate as to the annual cost of maintaining your son?

A. Well, it costs me around \$4,000 a month to maintain him.

Q. \$4,000?           A. A month—I mean a year.

Q. Do you, in your opinion—is there any reasonable likelihood that that cost might change materially in the coming years?

A. No, I don't believe so.

Q. Suppose your income were materially reduced, would it, in your opinion, still cost you \$4,000 a year to maintain your son?           A. No.

(Testimony of Mildred Irene Siegel.)

Q. In other words, you could do it cheaper if it were necessary? [37]      A. Yes.

Mr. Latham: I think that is all, your Honor.

The Court: All right.

Cross Examination

Q. (By Mr. Burke): Mrs. Siegel, the Palm Springs property has been sold, hasn't it?

A. Yes.

Q. When was that sold?

A. That was sold shortly after Mr. Siegel's death.

Q. Now, what is the nature of the property, your understanding of the property that is actually in your trust now? What kind of property? What does it consist mainly of?

A. Mostly of income apartments.

Q. Apartments?      A. Yes.

Q. Who manages those apartments?

A. The Consolidated Hotels.

Q. That is a corporation?      A. Yes, sir.

Q. You as trustee with Mr. Weingart and Mr. Allison, receive the net income from that——

A. Yes.

Q. ——operation?      A. Yes. [38]

Q. All right. What investments has the trust, you and Mr. Allison, Mr. Weingart, made since the formation of the trust, other than the receipt of income from these apartments which are managed by the corporation?

(Testimony of Mildred Irene Siegel.)

A. Well, we have bought stocks and first mortgages.

Q. To what extent, how much, in proportion to the total property in there, about what percentage would be devoted to this type of security?

A. I can't say.

Q. You have no idea?           A. No.

Q. Now, in your discussions as to what would happen to your interest if you did not elect to take under the will, I understand you had many of those?           A. Yes, sir.

Q. Did Mr. Weingart or anyone connected with the management corporation tell you that you would have to sell your interest in that property if it wasn't consolidated under one management?

A. Well, I would have to be liquidated.

Q. The whole interest in this real estate would have to be liquidated?

A. Well, some of it would have had to be in order to divide——

Q. Would you explain that to me? [39]

A. Well, there couldn't have been just an exact division without some liquidation.

Q. I don't mean that. You have, for example, the major portion of the assets in this estate consist of small fractional interests in real property. Now, that property is managed by a corporation?

A. That's right.

Q. Now, you would receive a fractional interest, as a beneficiary under the trust, and that is the way it is managed now, is that correct?

(Testimony of Mildred Irene Siegel.)

A. That's correct.

Q. Did anyone ever tell you that that couldn't be done if you didn't take under the will; you would still have the same fractional interests, be reduced, further reduced? Was there anyone—did anyone ever tell you that you couldn't do that?

A. No.

Q. When was it explained to you what would happen under the will if you took your election, was it explained to you that your son would then be vested with a substantial interest that he would not otherwise have?

A. I don't understand.

Q. Did you understand, when your election was being explained to you, did you fully understand at that time that, by virtue of your election, your son would then and there get a [40] vested interest, an interest in your property that he didn't have before?

A. That wasn't certain, because I had the right to invade the trust, the corporacy of the trust.

Q. That is what I mean. I am asking you was that explained to you?

A. He might not have gotten anything. I mean if I had—

Q. That's right. Was it explained to you?

A. Yes.

Q. Fully? In other words, you understood that your son was to take something under this will by virtue of your election?

(Testimony of Mildred Irene Siegel.)

A. Well, not a gift, certainly.

Q. Now, Mrs. Siegel, in other words, there's approximately a million dollars in this estate. There are several hundred thousand dollars worth of expenditures. There is an interest approximately in round figures, maybe several, about six or seven hundred thousand dollars going into a trust. Under the operation of that trust, after you die, your son is to get everything that is in that. Didn't you understand that to be the case?           A. Yes.

Q. Looking at these Exhibits 2, 3, 4, 5, 6, 7, and 8, practically all of these are identified except personal expenses other than the above. Could you look through those and, [41] one by one, looking at Exhibit 2, first, which I hand you, give us some idea, if you can remember, for example, in 1948, why that particular item designated "Personal expenses other than the above," is so high, and what the nature of those would be?

A. Well, the help and my clothes and—let's see, which year was this?

Mr. Latham: Will you speak up, please?

The Witness: It was the help, the gardening, the maintenance of the home.

Q. (By Mr. Burke): Are those the elements that go into that? Would there be anything else? '48, that is prior to your husband's death.

A. And entertaining, we did a very great deal of entertaining.

Q. What portion would you estimate would be apportionable to entertaining?

(Testimony of Mildred Irene Siegel.)

A. I couldn't say without looking at the books.

Q. Would that be the same situation with respect to 1949, for example, listed as "personal" on Exhibit 3, with respect to 1949, \$10,170; is that the same type of—

A. No, because that was the year after Mr. Siegel passed away, and I didn't do very much entertaining.

Q. During these years, '49, '50, '51, '52, '53, '54, [42] covered by these exhibits, did your son reside with you? A. No, he was in boarding school.

Q. Does the cost set out with respect to him include the full cost of these schools?

A. Yes, sir.

Q. And how long during the year would he be in school? A. Nine months.

Q. Was he with you with respect to the remaining three months of the year? A. Yes.

Q. He resided—

A. Maybe a few weeks in camp.

Q. So then he would be living with you during the remaining three months? A. Yes.

Q. Now, I believe you gave a statement to Mr. Latham as to what it cost you to support your son, and how much you could reduce that. How about that as applied to your own living? Could you venture an estimate of how much you could get along yourself with if your income were reduced?

A. Well, I haven't any idea.

Q. Clothing? A. If I were compelled to.  
Mr. Burke: Thank you very much. That is all.

Mr. Latham: That is all, Mrs. Siegel. [43]

The Court: All right, Mrs. Siegel.

(Witness excused.)

Whereupon,

BEN WEINGART

called as a witness for and on behalf of the Petitioner, having been first duly sworn, was examined and testified as follows:

Direct Examination

Q. (By Mr. Latham): Will you state your name, please? A. Ben Weingart.

Q. And your address?

A. 228 South Hudson Street.

Q. Los Angeles? A. Los Angeles.

Q. Your occupation?

A. Building, real estate, general business.

Q. How long have you been engaged in that business, businesses in Los Angeles?

A. 35, 40 years.

Q. You are one of the trustees named in the last will of Mr. Irving Siegel, deceased? A. I am.

Q. How long had you known Mr. Siegel in his lifetime? A. About 20 years.

Q. And did you have any other business association with [44] him?

A. Yes, we associated together, partners, equal partners.

Q. And you were at the time of his death?

A. Was.

Q. Had you and Mrs. Weingart had an occasion to visit socially with the Siegels and they with you?

(Testimony of Ben Weingart.)

A. Yes, many times.

Q. At the time of his death, you had been in their home and with them and were familiar with the way they lived? A. I was.

Q. Did Mr. Siegel discuss the terms of his will with you prior to his death? A. He did.

Q. Briefly, what did he tell you?

A. He told me that—we discussed it on several different times and spoke back and forth in reference to it, and he asked me my advice. And I made some suggestions to him in regard to it, and one of the results of the will was somewhat of my suggestion, with reference to the boy getting anything until he was of age, and the method that he should write up the will. He had some of his own ideas, and after he made the will, why, he asked me to go on as executor, and I suggested that he should get someone else, also, which he did; and this will was the result of conversations with him, I believe.

Q. After his death, did you discuss with Mrs. Siegel [45] her rights under the will?

A. I did, a number of occasions.

Q. Did you explain to her her rights as you understood them? A. I did.

Q. In your opinion, was she fully familiar with her various rights under the will?

A. I believe she was.

Q. That was true at the time she exercised her election? A. Correct.

Q. Prior to the exercise of that election, did she ask you what you thought she should do?



(Testimony of Ben Weingart.)

A. She certainly did, not only once but several times.

Q. What did you tell her?

A. I told her by all means that she should elect the right to take the whole.

Q. Now, did you tell her why?

A. I told her that if she did not take the whole, that two things would happen. One of them is that I don't believe that her income would be large enough out of her half for her to live the way she was living. And another thing, that I would be on the other side of the fence, in a judicial capacity of being an executor of the boy, under that side of the will, and I would be against her on—her side, in other words.

Q. If she took her half out? [46]

A. If she took her half out, I would take the position of being on the other side and looking after the boy's interests.

Q. You mentioned the whole, she should take the whole?           A. Well—

Q. What do you mean by that?

A. That means that she should take the selection of using the entire estate for her lifetime, and the income from that estate, which I believe that the income of that estate would be enough to support her and the boy under the terms of the will, and in my opinion that I didn't believe that she should have to go into the principal of the will, principal of the estate.

Q. If she elected to take under the will?

(Testimony of Ben Weingart.)

A. That's right.

Q. What was your opinion as to whether or not she would have to invade principal if she took out her half?

A. If she took out her half, she would have to then go——

Mr. Burke: Your Honor, I believe that calls for an opinion of what might happen in the event of certain facts within the contemplation of Mrs. Siegel, rather than Mr. Weingart. I don't believe it is a proper question. I object.

The Court: He has been permitted to testify what advice was given.

What is the question, please, that is now pending? [47]

(Question read.)

The Court: Well, I will overrule the objection.

A. (Continuing) And use some of her estate for the purpose of supporting herself and the boy in the proper manner that she has been doing.

Q. (By Mr. Latham): You pointed that out to her, in considering what she should do?

A. Correct.

Q. Mr. Weingart, I notice that the evidence here shows that during 1951, '52, '53, and '54, Mrs. Siegel received from the trust an average of \$52,000 per year. Did you, as one of the trustees, determine the amount to be distributed to her in each one of those years?

A. I did. I discussed it with Mr. Allison, and I discussed it with Mrs. Siegel, and she said she

(Testimony of Ben Weingart.)

would have to have more money, that after she had paid her income tax that she wouldn't have enough. And after checking with her and talking to her several times, we decided that she should have more, and we gave it to her, because the income of the estate, if I recall, was enough to give her this amount without going into the principal of the estate.

Q. Was it your opinion——

A. My opinion that that amount was about what she was spending, to keep up with conditions changing and prices were [48] going up.

Q. As one of the trustees, did you determine that those amounts were necessary in order for her to maintain the standard of living to which she was accustomed at the time of the date of her husband's death?

A. I will state this: I knew Irving Siegel very well, and I took this position, that if he were here he would instruct me to give her that amount of money, and that's the position I took. I felt it was the right thing to do.

Q. And in accordance with your judgment in accordance with the terms of the will?

A. That's correct.

Mr. Latham: I think that is all.

The Court: All right.

#### Cross Examination

Q. (By Mr. Burke): When you and Mr. Allison and Mrs. Siegel came to discuss what would be

(Testimony of Ben Weingart.)

necessary for her support in a given year, what were the actual steps that transpired in reaching that determination?

A. I had talked with Mrs. Siegel several times, and I telephoned to Mr. Allison and discussed the matter over the phone with him.

Q. I see.

A. Mrs. Siegel, I talked to her personally several times, [49] went to her house, and also over the telephone.

Q. What would she say in those situations?

A. She'd say, "Well, my expenses are up," and she says, "I just don't have anything at all left." She says, "I will have to take money out of my own account to support myself."

She made those statements, so I felt it was only fair.

Mr. Burke: Thank you very much. That is all.

Mr. Latham: That is all.

The Court: That is all, Mr. Weingart.

(Witness excused.)

Mr. Latham: If your Honor please, that is the petitioner's case, and the petitioner rests.

Mr. Burke: The respondent has no witnesses, your Honor, and the respondent rests.

The Court: Very well, the documents are all in, and your stipulation.

What length of time would you gentlemen like to have for any briefs in this case?

Mr. Latham: So far as the petitioner is concerned, we can do it within 30 days after we get the transcript.

Mr. Burke: I have some other pressing problems.

Mr. Latham: You have no other cases, have you, Mr. Burke?

Mr. Burke: There, again, Mr. Latham is telling me what is going on in my office. But I would like, as long as [50] possible, commensurate with the burden that the Court now has on its hands.

The Court: Yes, well, we have of course quite a number of cases submitted ahead of this. It would be several months before we could expect to reach this case in the ordinary procedure, and in the case we tried this morning, I allowed until September 1st for filing of briefs. Of course, you can file them sooner if you get them ready.

Mr. Latham: If you are going to set a date ahead for the respondent, we might as well take—I would like to get the case briefed as soon as possible.

The Court: You can file it at any time, Mr. Latham.

Mr. Latham: Do you want simultaneous briefs?

The Court: Yes, I suppose so. There is no reason it should be otherwise, is there? You have stipulated all the facts. Or do you want——

Mr. Burke: It really makes no difference to me, your Honor. I think simultaneous briefs would be perfectly all right.

Mr. Latham: It is all right with me.

The Court: You could choose what they call seriatim briefs, which would mean the petitioner would file first and then the respondent would have

30 days after that. Which method would you like to use?

Mr. Latham: It doesn't make any difference to me, as [51] far as that is concerned. We can file simultaneous briefs.

The Court: I imagine in this case, where the facts are all stipulated, it is more a question of law, I think, probably than anything else, probably simultaneous briefs, and then with the right, of course, to reply, each one to file a reply brief.

Mr. Burke: That will be perfectly all right with the respondent, your Honor.

The Court: Well——

Mr. Latham: September 1st?

The Court: September 1st you desire?

Mr. Burke: I would like September 1st.

The Court: Well, it wouldn't delay the Court, I know that, because of cases submitted elsewhere, it would certainly be several months before we could reach this in the ordinary course. So there would be no delay by giving you until September 1st, so you are granted until September 1st in which to file your briefs.

Would you like 20 days or 30 days in which to file your reply briefs?

Mr. Latham: I can do it in 20 days. If Mr. Burke wants 30, we certainly won't object.

Mr. Burke: I think I will probably file a reply in this case. I am not sure. The way it looks now, I probably will. We need five days for review, probably 30 days would be [52] better.

The Court: I guess that is better, because fre-

quently if we make it the shorter time we have to have motions for extensions, and knowing as the Court does know, it will be several months before we can expect to reach this case, and that will not delay it. So September 30, 1955 is fixed as the time for the filing of reply briefs.

Mr. Latham: Thank you.

Mr. Burke: Thank you.

(Whereupon, at 3:20 p.m., the hearing was closed.) [53]

[Endorsed]: T.C.U.S. Filed July 15, 1955.

---

## PETITIONER'S EXHIBIT No. 2

IRVING SIEGEL and MILDRED SIEGEL

EXPENSES FROM JAN. 1, 1948 to DEC. 31, 1948

(As per Ledger)

Cadillac automobile .....	\$ 5,173.72
Insurance—Life and residence .....	2,224.45
Medical .....	3,887.00
Contributions to charity .....	127.00
Tax analysis .....	302.79
R. E. taxes and assessments on two residences and pers. prop. taxes .....	1,789.71
State and City sales tax.....	294.60
Personal expenses other than above.....	32,339.59
Interest on mortgage on Palm Springs residence.....	412.63
	<hr/>
	\$ 46,551.49 S
Director of Internal Revenue—balance 1947 tax and on acct. 1948 .....	\$145,572.70
Franchise Tax Board—1947 tax .....	23,296.38
	<hr/>
Total.....	<u>\$215,420.57 *</u>

## PETITIONER'S EXHIBIT No. 3

MILDRED SIEGEL

CASH ACCOUNT FOR 1949

## EXPENDITURES:

Automobile expense .....	\$ 370.98
Contributions to charity .....	490.00
Insurance—Life, prop, compre, W. C.....	1,306.70
Personal .....	10,170.10
Medical .....	442.21
For son—Clothes .....	141.85
Medical .....	1,187.33
School .....	372.50
Household employees .....	4,270.43
Food, etc. ....	2,728.61
Utilities .....	869.87
Gardener, maintenance and repairs .....	942.87
R. E. taxes and assessments .....	809.55
	<hr/>
Total.....	\$ 24,103.00 *
	<hr/> <hr/>
Allowance from the Estates .....	\$ 27,333.33
Deposited in Savings Account .....	833.33 -
	<hr/>
	\$ 26,500.00 S
New England Mut Life Ins—dividend.....	143.55
Bullock's—refund on furniture .....	396.19
	<hr/>
	\$ 27,039.74 S
	<hr/>
Balance on hand Jan. 4, 1949.....	\$7,150.46
Less check to Louis Boyar.....	5,000.00
	<hr/>
	\$ 2,150.46
Total expenditures in 1949 .....	24,103.00 -
	<hr/>
Balance on hand December 31, 1949.....	\$ 5,087.20 *
	<hr/> <hr/>



## PETITIONER'S EXHIBIT No. 4

## MILDRED SIEGEL

## CASH ACCOUNT FOR 1950

## EXPENDITURES:

Deposit on new automobile .....	\$ 250.00
Automobile expense .....	929.00
Contributions to charity .....	682.00
Insurance—Life, auto, compre, W. C.....	531.41
Personal .....	12,403.86
Medical .....	626.29
For son—Clothes .....	354.49
Medical .....	125.77
School, etc. ....	2,142.97
Household employees .....	3,720.96
Food .....	2,221.32
Utilities .....	1,065.99
Gardener, maintenance and repairs .....	797.05
R. E. taxes and assessments .....	1,369.21
Federal income tax .....	4,500.00

Total.....\$ 31,720.32 \*

Allowance from the Estate.....	\$ 18,000.00	
Distribution from the Trust .....	24,000.00	\$ 42,000.00

Deposited in Savings Account.....	3,500.0	—
Invested in U. S. Savings Bonds.....	575.00	—

\$ 37,925.00 S

Balance on hand Jan. 1, 1950.....	5,087.20
Total expenditures in 1950 .....	31,720.32 —

Balance on hand December 31, 1950.....\$ 11,291.88 \*

## PETITIONER'S EXHIBIT No. 5

MILDRED SIEGEL

## CASH ACCOUNT FOR 1951

## EXPENDITURES:

Furniture .....	\$ 250.00
Automobile (balance cost) .....	4,142.26
Automobile expense .....	468.63
Contributions to charity .....	385.00
Insurance—Life, auto, compre, W. C.....	993.91
Personal .....	13,689.25
Medical .....	583.13
For son—Clothes .....	112.95
Medical .....	74.77
Schools, camp .....	1,303.77
Household employees .....	3,250.00
Food .....	1,542.23
Utilities .....	1,009.11
Gardener, maintenance and repairs .....	1,258.96
Tax consultant—fee .....	1,500.00
R. E. taxes and assessments.....	1,354.38
Federal income tax .....	17,607.63
State income tax .....	916.60
F.I.C. on household employees .....	19.53
	<hr/>
Total.....	\$ 50,462.11 *
	<hr/> <hr/>
Distribution from the Trust .....	\$ 54,000.00
Deposited in Savings Account .....	7,100.00 -
Loans Receivable .....	100.00 -
	<hr/>
	\$ 46,800.00 S
	<hr/>
Balance on hand Jan. 1, 1951 .....	11,291.88
Total expenditures in 1951 .....	50,462.11 -
	<hr/>
Balance on hand December 31, 1951.....	\$ 7,629.77 *
	<hr/> <hr/>

## PETITIONER'S EXHIBIT No. 6

## MILDRED SIEGEL

## CASH ACCOUNT FOR 1952

## EXPENDITURES:

Furniture .....	\$ 121.54
Auto expense .....	322.57
Contributions to charity .....	325.00
Insurance—Life, auto, prop. compre, W. C. ....	981.49
Personal .....	8,275.23
Medical .....	484.73
For son—Clothes .....	229.05
Medical .....	106.50
School, camp .....	2,062.11
Household employees .....	3,917.50
Food .....	1,269.40
Utilities .....	993.18
Gardener, maintenance and repairs.....	1,943.61
R. E. and pers prop taxes, assessments, auto license .....	1,922.55
Federal income tax .....	19,139.51
State income tax .....	1,157.32
F.I.C. on household employees .....	62.31
	<hr/>
Total.....	\$ 43,313.60 *
	<hr/> <hr/>
Distribution from the Trust .....	\$ 54,000.00
Deposited in Savings Account .....	14,000.00 -
Invested in stock .....	500.00 -
	<hr/>
	\$ 39,500.00 S
Social Security survivors ins.....	100.00
Balance on hand Jan. 1, 1952.....	7,629.77
Total expenditures in 1952 .....	43,313.60 -
	<hr/>
Balance on hand December 31, 1952.....	\$ 3,916.17 *
	<hr/> <hr/>

## PETITIONER'S EXHIBIT No. 7

## MILDRED SIEGEL

## CASH ACCOUNT FOR 1953

## EXPENDITURES:

1953 Cadillac automobile .....	\$ 5,409.81
Rec'd for 1951 Cadillac .....	1,850.00 -
Net.....	3,559.81 S
Television set .....	310.00
Automobile expense .....	291.94
Contributions to charity .....	185.00
Insurance—Life, prop, compre, W. C.....	1,013.74
Personal expenses .....	6,982.20
Medical .....	599.84
For son—Clothes .....	194.17
Medical .....	175.00
School and camp .....	2,401.88
Household employees .....	4,672.50
Food, etc. ....	1,131.30
Utilities .....	970.07
Gardener, maintenance and repairs .....	2,376.98
Accounting fees .....	1,634.17
R. E. and pers prop taxes, assessments, auto license, etc. ....	1,682.21
Federal income tax .....	17,079.99
State income tax .....	1,333.07
F.I.C. on household employees .....	62.92
	<hr/>
Total.....	\$ 46,656.79 *
	<hr/>
Distribution from Trust .....	\$ 52,000.00
Less deposited in Savings Account.....	4,012.22 -
	<hr/>
Balance.....	\$ 47,987.78 S
	<hr/>
Cash on hand January 1, 1953.....	3,916.17
Total expenditures in 1953 .....	46,656.79 -
Balance on hand December 31, 1953.....	5,247.16 *
	<hr/>

## PETITIONER'S EXHIBIT No. 8

## MILDRED SIEGEL

## CASH ACCOUNT FOR 1954

## EXPENDITURES:

Automobile expense .....	\$ 288.20
Contributions to charity .....	355.00
Insurance—Life, prop, compre, W. C. ....	892.23
Personal expense .....	8,329.39
Medical .....	494.39
For son—Clothes .....	174.05
Medical .....	93.50
School and camp .....	3,450.62
Household employees .....	4,681.41
Food, etc. ....	1,606.95
Utilities .....	905.21
Gardener, maintenance and repairs .....	1,839.57
Accounting fee .....	250.00
Prop. and pers prop taxes, assessments, auto license, etc. ....	1,496.61
Federal income tax .....	21,065.73
State income tax .....	1,263.66
F.I.C. on household employees .....	81.46
	<hr/>
Total.....	\$ 47,267.98 *
	<hr/> <hr/>
Distribution from Trust .....	\$ 48,000.00
Less deposited in Savings Account .....	4,000.00 -
Less invested in State of Israel Bond.....	100.00 -
	<hr/>
Balance.....	\$ 43,900.00 S
	<hr/>
Cash on hand January 1, 1954.....	5,247.16
Total expenditures in 1954 .....	47,267.98 -
Balance on hand December 31, 1954.....	\$ 1,879.18 *
	<hr/> <hr/>

[Endorsed]: No. 15432. United States Court of Appeals for the Ninth Circuit. Commissioner of Internal Revenue, Petitioner, vs. Mildred Irene Siegel, Respondent. Transcript of the Record. Petition to Review a Decision of The Tax Court of the United States.

Filed: February 11, 1957.

/s/ PAUL P. O'BRIEN,  
Clerk of the United States Court of Appeals for  
the Ninth Circuit.

In the United States Court of Appeals  
for the Ninth Circuit

No. 15432

COMMISSIONER OF INTERNAL REVENUE,  
Petitioner,

vs.

MILDRED IRENE SIEGEL, Respondent.

STATEMENT OF POINTS AND DESIGNA-  
TION OF RECORD

Comes Now the petitioner on review herein, and pursuant to the provisions of Rule 17(6) of this Court, adopts the Statement of Points and the Designation of Contents of Record on Review as the same appear in the certified typewritten transcript of record in the above cause.

/s/ CHARLES K. RICE,  
Assistant Attorney General

[Endorsed]: Filed February 28, 1957. Paul P. O'Brien, Clerk.





No. 15432

---

In the United States Court of Appeals  
for the Ninth Circuit

---

COMMISSIONER OF INTERNAL REVENUE, PETITIONER

*v.*

MILDRED IRENE SIEGEL, RESPONDENT

---

On Petition for Review of the Decision of the  
Tax Court of the United States

---

BRIEF FOR THE PETITIONER

---

CHARLES K. RICE,  
*Assistant Attorney General.*

ELLIS N. SLACK,  
LEE A. JACKSON,  
HELEN A. BUCKLEY,  
*Attorneys,*  
*Department of Justice,*  
*Washington 25, D. C.*

---

FILED

MAY 25 1957



## INDEX

	Page
Opinion below .....	1
Jurisdiction .....	1
Question presented .....	2
Statute involved .....	2
Statement .....	3
Statement of points to be argued.....	4
Summary of argument.....	5
Argument:	
The gift by the taxpayer is measured by the value of her community interest reduced only by the life estate that she retained therein.....	6
Conclusion .....	12

## CITATIONS

### Cases:

<i>Commissioner v. McLean</i> , 127 F. 2d 942.....	10
<i>Fire Insurance Assn. v. Wickham</i> , 141 U.S. 564....	9
<i>Giannini v. Commissioner</i> , 148 F. 2d 285, certiorari denied, 326 U.S. 730.....	10
<i>McFarland v. Campbell</i> , 213 F. 2d 855.....	10
<i>Philpot v. Gruninger</i> , 81 U.S. 570.....	8
<i>Siegel v. Commissioner</i> , 26 T.C. 743.....	1
<i>Warner v. Commissioner</i> , 66 F. 2d 403, certiorari denied, 290 U.S. 688.....	9

### Statute:

#### Internal Revenue Code of 1939:

Sec. 1000 (26 U.S.C. 1952 ed., Sec. 1000).....	2
Sec. 1002 (26 U.S.C. 1952 ed., Sec. 1002).....	3, 7



**In the United States Court of Appeals  
for the Ninth Circuit**

---

No. 15432

COMMISSIONER OF INTERNAL REVENUE, PETITIONER

*v.*

MILDRED IRENE SIEGEL, RESPONDENT

On Petition for Review of the Decision of the  
Tax Court of the United States

---

**BRIEF FOR THE PETITIONER**

---

**OPINION BELOW**

The opinion of the Tax Court (R. 30-42) is reported at 26 T.C. 743.

**JURISDICTION**

This petition for review (R. 43-45) involves federal gift tax for the taxable year 1950. On February 8, 1954, the Commissioner of Internal Revenue mailed to the taxpayer notice of a deficiency in the total amount of \$51,144.24. (R. 12-15.) Within ninety days thereafter and on April 29, 1954, the taxpayer filed a petition with the Tax Court for a redetermination of that deficiency under the provisions of Section 6213 of the Internal Revenue Code of 1954. (R.

6-15.) The decision of the Tax Court was entered October 3, 1956. (R. 42-43.) The case is brought to this Court by a petition for review filed December 20, 1956. (R. 43-45.) Jurisdiction is conferred on this Court by Section 7482 of the Internal Revenue Code of 1954.

### QUESTION PRESENTED

Taxpayer's wife elected to take under the terms of her deceased husband's will in lieu of taking her share of the community property, the will providing that she was to have a life estate in all the community property plus a specific bequest. Should the amount of the gift by the wife resulting from such election be measured by the wife's one-half of the community reduced only by the present value of the life estate she retained therein, or should it be further reduced by the present value of her life estate in the husband's one-half of the community and by the specific bequest?

### STATUTE INVOLVED

Internal Revenue Code of 1939:

#### SEC. 1000. IMPOSITION OF TAX.

(a) For the calendar year 1940 and each calendar year thereafter a tax, computed as provided in section 1001, shall be imposed upon the transfer during such calendar year by any individual, resident or nonresident, of property by gift. \* \* \*

(b) The tax shall apply whether the transfer is in trust or otherwise, whether the gift is direct or indirect, and whether the property is real

or personal, tangible or intangible; but, in the case of a nonresident not a citizen of the United States, shall apply to a transfer only if the property is situated within the United States.

(26 U.S.C. 1952 Ed., Sec. 1000.)

**SEC. 1002. TRANSFER FOR LESS THAN ADEQUATE AND FULL CONSIDERATION.**

Where property is transferred for less than an adequate and full consideration in money or money's worth, then the amount by which the value of the property exceeded the value of the consideration shall, for the purpose of the tax imposed by this chapter, be deemed a gift, and shall be included in computing the amount of gifts made during the calendar year.

(26 U.S.C. 1952 ed., Sec. 1002.)

**STATEMENT**

This case involves a gift tax for the year 1950 in the amount of \$46,829.37. Most of the facts were stipulated (R. 18-29) and so found by the Tax Court (R. 31-36).

The taxpayer is a resident of California. (R. 31.) Her husband, who died in 1949, left an estate consisting of community property, in all of which the taxpayer had a vested one-half interest. (R. 32.) The husband's will purportedly disposed of the entire community estate despite the vested interest of the taxpayer in her half of the community. Under the will the taxpayer was given a life estate in the community along with a specific bequest of \$35,000 and certain specified items of real and personal property. It was provided that the provisions on behalf of the

wife were made in lieu of her community rights and that if she elected to take her community interest then she would not take under the terms of the will. (R. 32-34.) The taxpayer elected to take under the will in lieu of her community property rights. (R. 34.)

The Commissioner of Internal Revenue determined, and was upheld by the Tax Court, that this election constituted a gift by the taxpayer to the remainderman of the trust set up by the husband. The sole controversy to be determined upon this review is the valuation to be placed upon such gift. It is the position of the Commissioner that the gift must be measured by the wife's one-half of the community reduced only by the life estate she retained in such one-half. The Tax Court held that the taxpayer made a gift to the extent of her one-half of the community estate less the life interest she retained in such one-half reduced further by the value of the life estate received by her in the other one-half of the community and by the \$35,000 bequest. (R. 30.)

From this decision the Commissioner here petitions for review. (R. 43-45.)

#### STATEMENT OF POINTS TO BE URGED

1. The Tax Court erred in holding that the amount of the gift should be measured by taxpayer's community one-half reduced by the present value of her life interest in the entire community and a specific bequest granted to her by the terms of the will.

2. The Tax Court erred in failing to hold that the amount of the gift should be measured by taxpayer's



community one-half reduced only by the present value of the life estate that she retained therein.

### SUMMARY OF ARGUMENT

The only question on review is the matter of evaluation of the gift made by the taxpayer to the remainderman of the trust. The Tax Court proceeded upon the premise that the property which the taxpayer received under the terms of her husband's will constituted consideration for the transfer which she made by her election to take under the will, and accordingly deducted from the amount of the gift made the bequests received by the wife under the will. In this the Tax Court erred. The entire transaction was donative in character and the taxpayer received no consideration whatsoever, adequate or not, for making the election. The Tax Court failed to make the basic distinction between the *motive* for the taxpayer's action and the *consideration* for such action. While the terms of the husband's will may certainly have strongly motivated the taxpayer in her election, the terms could not constitute consideration for the election. What she received from her husband's estate was solely through the largess of her husband. There was not present the bargain or agreement between the taxpayer and her husband necessary to constitute these bequests as consideration, and obviously it was not possible for them to have reached such bargain or agreement. Nothing is consideration that is not regarded as such by both parties, and this Court has stated that consideration will not be presumed. Accordingly, the Tax Court erred in consid-

ering the acquisitions of the wife under the terms of her husband's will as consideration for the gift which she made to the remainderman, and the decision should be reversed.

### ARGUMENT

#### **The Gift By the Taxpayer Is Measured By the Value of Her Community Interest Reduced Only By the Life Estate That She Retained Therein**

The only point at controversy in this review is the evaluation to be placed upon the gift which the Tax Court held was made by the taxpayer to the remainderman of the trust set up by her husband. That a gift of some amount was made is clear from the facts and applicable law and was the holding of the Tax Court. Since the taxpayer has not appealed from this holding, it may be disregarded entirely for the purposes of this review and our sole attention is accordingly directed to the matter of the evaluation of the gift.

The Commissioner has consistently contended that the taxable gift made by the taxpayer should be measured by the value of her interest in the community less the life estate which she retained in that community interest. It is the position of the taxpayer, on the other hand, that the gift consisted of her share of the community less the life estate she retained therein, further reduced by that which she received under her husband's will: the life estate in her husband's share of the community and the specific bequest of \$35,000. The Tax Court in this respect agreed with the taxpayer and stated (R. 37):

We have recently enunciated the basic principles applicable to situations of this type in *Chase National Bank*, 25 T.C. 617.\* It is clear from a reading of that case that petitioner must be considered as having made a gift to the extent that the value of the interest she surrendered in her share of the community property exceeded the value of the interest she thereby acquired under the terms of Irving's will.

The premise upon which the Tax Court implicitly based its decision could only have been that the property which the taxpayer received by the terms of her husband's will constituted consideration for the transfer which she made by her election to take under the will. Section 1002, *supra*, of the Internal Revenue Code of 1939 provides—

SEC. 1002. TRANSFER FOR LESS THAN ADEQUATE AND FULL CONSIDERATION.

Where property is transferred for less than an adequate and full consideration in money or money's worth, then the amount by which the value of the property exceeded the value of the consideration shall, for the purpose of the tax imposed by this chapter, be deemed a gift, and shall be included in computing the amount of gifts made during the calendar year.

The decision of the Tax Court must necessarily have presupposed that there was some consideration involved in this case, and in such a supposition, it is submitted, lies the fallacy in the Tax Court's view.

---

\* Appeal by the Government pending in the Court of Appeals for the Fifth Circuit.

This entire transaction was donative in character and the taxpayer received no consideration whatsoever, adequate or not, for making the election.

The Tax Court has done here that which was long ago condemned by the Supreme Court in another situation: it has failed to distinguish between the *motive* for doing something and the *consideration* received for such undertaking. "It is, however, not to be doubted that there is a clear distinction sometimes between the motive that may induce to entering into a contract and the consideration of the contract." *Philpot v. Gruninger*, 81 U.S. 570, 577. The taxpayer, in making this election, may certainly have been strongly influenced one way or the other by the provision which her husband had made for her in his will, but this fact alone does not make the bequests received consideration for the gifts which she made. The taxpayer received a life estate in her husband's share of the community and the bequest of \$35,000 solely by the largess of her husband. Although the husband's gift by will may have been contingent upon the fulfillment of certain conditions by the taxpayer, it was nonetheless a gift. Indeed there could not have been the bargain or agreement between the taxpayer and the husband necessary to constitute these bequests as consideration under the circumstances of this case where the husband was already deceased at the time of the transfer. The Tax Court failed to hold that there was any arm's length bargain such as is usually associated with transfers for consideration. "Nothing", said the Supreme Court in *Philpot, supra*, p. 577, "is consid-

eration that is not regarded as such by both parties." See also *Fire Insurance Assn. v. Wickham*, 141 U.S. 564. At the time of the taxpayer's gift her husband clearly could not have regarded his bequest as consideration for her election. Additionally, there has not been and could not validly be any contention put forth that the beneficiary of the wife's bounty, the remainderman of the trust, put up any consideration for the action of the wife in making the election to take under the terms of the will in lieu of her community property rights.

That there was no consideration for a similar election by a wife was succinctly set forth by the Court of Appeals for the Second Circuit in a case involving the common law rights of the wife to dower. *Warner v. Commissioner*, 66 F. 2d 403, certiorari denied, 290 U.S. 688. In denying the Commissioner the right to tax as income the difference between the wife's dower interest and what she received under a will setting up provision for her in lieu of her dower interest, the court stated (p. 406):

But it does not follow that the widow's share under the will is not taken by bequest, at least to the extent that her share under the will exceeds the value of her right of dower. A testator's provision for his widow in lieu of dower is simply a gift conditional upon her giving up the dower. The condition attached to the gift may indeed operate as an inducement to her to relinquish her statutory rights. But, to the extent that her share under the will exceeds her rights as widow, she clearly accepts the bounty of the testator, and gives nothing in consideration therefor by way of purchase.

The Court in *Warner* has made the clear distinction between the inducement to do something and the consideration for such action as was set forth in *Philpot, supra*. The Tax Court erred in failing to recognize this difference. See also the dictum of the Fifth Circuit in *McFarland v. Campbell*, 213 F. 2d 855, 857: "In order that the necessity of an election shall take place, the testator must affect to dispose of property which is not his own, and also make a valid *gift* of his own property." (Italics supplied.)

The mere statement by the taxpayer that the transfer which she made was in return for the "consideration" which she received under the terms of her husband's will is not sufficient to turn the bequests of the husband into "consideration" of any legal efficacy. There is nothing at all to show that the bequests by the husband were other than donative in intent and in effect, and there is no valid reason for a contrary inference. Consideration should not be presumed. See *Commissioner v. McLean*, 127 F. 2d 942 (C.A. 5th). The situation is similar to that before this Court in *Giannini v. Commissioner*, 148 F. 2d 285, certiorari denied, 326 U.S. 730, where property was placed in trust as a result of a family arrangement and it was contended that there was a transfer for an adequate and full consideration in money's worth and not a gift. In holding that there was a gift and not a sale, this Court stated (p. 287):

Neither do the facts show any consideration in money or money's worth for the decedent's transfer of property to the trust. True, the decedent received an income interest in the family trust

worth more in money than the property he transferred to the trust. The disproportionate value of the income received resulted, however, not from bargaining but from the largess of the parents in donating a substantial sum for their children's financial security.

Here too there was no bargaining done by the taxpayer with either her deceased husband or with the remainderman of the trust, her young son. She received nothing as consideration for making the election. Whatever she acquired under the terms of her husband's will came to her not by way of sale or exchange but rather as a pure gift from him. Accordingly, the Tax Court erred in considering such acquisitions under the terms of her husband's will as consideration for the gift which she made to the remainderman.

## CONCLUSION

It is urged that for the reasons set forth above, the Tax Court erred in its holding that the gift which was made by the taxpayer should be reduced by the bequests she received under the terms of her husband's will, and this decision should be reversed.

Respectfully submitted,

CHARLES K. RICE,  
*Assistant Attorney General.*

ELLIS N. SLACK,  
LEE A. JACKSON,  
HELEN A. BUCKLEY,  
*Attorneys,*  
*Department of Justice,*  
*Washington 25, D. C.*

MAY, 1957.



No. 15432

IN THE

# United States Court of Appeals

FOR THE NINTH CIRCUIT

---

COMMISSIONER OF INTERNAL REVENUE,

*Petitioner,*

*vs.*

MILDRED IRENE SIEGEL,

*Respondent.*

---

On Petition for Review of the Decision of the Tax Court  
of the United States.

---

## BRIEF FOR THE RESPONDENT.

---

DANA LATHAM,

A. R. KIMBROUGH,

HENRY C. DIEHL,

GROVER HEYLER,

900 Wilshire Boulevard,  
Los Angeles 17, California,

*Attorneys for Respondent.*

FILED

JUN 25 1957

PAUL P. O'BRIEN, CLERK



## TOPICAL INDEX

	PAGE
Opinion below .....	1
Jurisdiction .....	1
Question presented .....	2
Statute involved .....	2
Statement of case.....	2
Summary of argument and points to be urged.....	5
Argument .....	6
A. A will requiring an election extends an offer to the widow of a consideration in exchange for the rights which she is asked to relinquish.....	6
B. The evidence shows that the widow accepted a life estate worth \$159,335.43 and a bequest of \$35,000 in exchange for placing her property in trust. The benefits received by the widow substantially offset her transfer and a tax is payable only on the excess value.....	8
C. The petitioner has not sustained his burden of showing that the trial court erred.....	12
Conclusion .....	14

## TABLE OF AUTHORITIES CITED

CASES	PAGE
Bergan, Sarah A., Estate of, 1 T. C. 543, acq. 1943 CB 2.....	12
Chase National Bank, 25 T. C. 617.....	6
Commission v. McLean, 127 F. 2d 942.....	13
Davis v. Mather, 309 Ill. 284, 141 N. E. 209.....	7
Fire Insurance Ass'n v. Wickham, 141 U. S. 564.....	13
Flanagan v. Capital National Bank, 213 Cal. 664, 3 P. 2d 307....	11
Giannini v. Comm., 148 F. 2d 285, cert. den. 326 U. S. 730.....	14
Gowling v. Gowling, 405 Ill. 165, 90 N. E. 2d 188.....	7
Grace Bros. Inc. v. Comm., 173 F. 2d 170.....	13
Lehman v. Comm., 109 F. 2d 99.....	11
McCarthy Co. v. Comm., 80 F 2d 618.....	13
McFarland v. Campbell, 213 F. 2d 855.....	14
Muse v. Muse, 186 Va. 914, 45 S. E. 2d 158, 2 A. L. R. 2d 603..	10
Philpot v. Gruninger, 81 U. S. 570, 20 L. Ed. 743.....	12
Staley, Augustus E., 41 BTA 752, acq. 1941-1 CB 15.....	12
Title Guarantee Loan & Trust Co. v. Comm., 63 F. 2d 621, aff'd 290 U. S. 365, 54 S. Ct. 221.....	10
Warner v. Comm., 66 F. 2d 403, cert. den. 290 U. S. 688.....	12
Wells Fargo Bank (Estate of Bibson) v. United States, ..... F. 2d ....., 57-1 USTC par. 9,653.....	11
Wyss, Estate of, 112 Cal. App. 487, 297 Pac. 100.....	11
DICTIONARY	
Webster's New International Dictionary (2d Ed.),.....	7
STATUTES	
Internal Revenue Code of 1939, Sec. 1002.....	2
Internal Revenue Code of 1954, Sec. 7482.....	1
TEXTBOOKS	
Page on Wills (Lifetime Ed.), Sec. 1346.....	6
Page on Wills, Sec. 1501.....	10
Page on Wills, Sec. 1502.....	10
Williston on Contracts, Sec. 13.....	7
Williston on Contracts, Sec. 25.....	8
Williston on Contracts, Sec. 101.....	9
Williston on Contracts, Sec. 113.....	9

No. 15432

IN THE

# United States Court of Appeals

FOR THE NINTH CIRCUIT

---

COMMISSIONER OF INTERNAL REVENUE,

*Petitioner,*

*vs.*

MILDRED IRENE SIEGEL,

*Respondent.*

---

On Petition for Review of the Decision of the Tax Court  
of the United States.

---

## BRIEF FOR THE RESPONDENT.

---

### Opinion Below.

The opinion of the Tax Court of the United States [R. 30-42] is reported at 26 T. C. 743.

### Jurisdiction.

This proceeding involves federal gift tax for the calendar year 1950. A statutory notice of deficiency [R. 12-15] was mailed to respondent on February 8, 1954. Within the time and in the manner and form provided by law, respondent petitioned the Tax Court of the United States for a redetermination of that deficiency. [R. 6-15.] The decision of the Tax Court of the United States was entered October 3, 1956. [R. 42-43.] The Commissioner petitioned for review on December 20, 1956. [R. 43-45.] Jurisdiction is conferred on this Court by Section 7482 of the Internal Revenue Code of 1954.

### Question Presented.

Respondent elected to take the benefits offered to her in her husband's will. In exchange for the benefits so obtained, she transferred her community property to the trust established under the will. The Tax Court held that the widow's transfer was made in consideration of the provisions offered in the will and that only the excess of her transfer over what she received was a taxable gift. The tax on this excess was determined by the Court and has been paid.

There is no conflict in the evidence. The issue is whether as a matter of law the widow received nothing whatever in money or money's worth for transferring her property to the trust.

### Statute Involved.

Internal Revenue Code of 1939, Section 1002. *Transfer for Less Than Adequate and Full Consideration.*

“Where property is transferred for less than an adequate and full consideration in money or money's worth, then the amount by which the value of the property exceeded the value of the consideration shall, for the purpose of the tax imposed by this chapter, be deemed a gift, and shall be included in computing the amount of gifts made during the calendar year. (26 U. S. C. 1952 ed., Sec. 1002.)”

### Statement of Case.

Irving Siegel died in 1949 and was survived by a son, and by his widow, the respondent herein. The property of the parties was all community property. The husband by his will purported to dispose of the entire community property including the wife's share. Most of the property went into a trust and its income was payable to the widow for

life. The trust remainder went to the son. [R. 22-29.]  
The pertinent provisions of the will are as follows:

“Eight: The provisions made in this my Last Will and Testament for my beloved wife, Mildred Irene Siegel, *are in lieu of her community rights and interest*, and if she elects to take her community interest, in lieu of taking under this my Last Will and Testament, then the bequests made to her in paragraph Three hereof shall be of no force and effect and the real and personal property so bequeathed shall become a part of the rest, residue and remainder of my said estate to be distributed to my said trustees, and likewise subdivision (a) of paragraph Seven shall be of no force and effect *and she shall take nothing as a beneficiary under said trust.*” (Italics added.) [R. 28.]

The acceptance of the offer made in her husband’s will filed by the widow on January 5, 1950 reads as follows:

“Election of Widow to Take Under Will

“I, the undersigned, Mildred I. Siegel, widow of Irving Siegel, deceased, do hereby elect to take under the Last Will and Testament of said deceased *in lieu of any and all community property rights which I have* in said estate.” (Italics added.)

“Dated this 5th day of January, 1950

Mildred Irene Siegel  
(Mildred Irene Siegel)” [R. 19]

The testimony shows [R. 79-81] that prior to making the election the widow carefully considered the available choices and obtained outside advice with respect to the course of action she should pursue and only after so doing accepted the proffered bequests and the life income

in her husband's one-half of the community because in her words [R. 81] “. . . I would be very much better off taking under the will.”

This case then originated with the assertion of a gift tax deficiency against respondent for 1950. [R. 12-15.] At the trial the tax demanded was reduced to \$46,829.37. [R. 20, 36-37.] (Pet. Op. Br. p. 3.) This is the amount of tax which, subject to credit for the prior payment, would be due if no consideration in money or money's worth was given to the widow in exchange for the relinquishment of her property.

The difference between what the widow gave up and what she received, according to the decision below, was \$74,332.55. Respondent has not challenged this determination and has paid her tax thereon. Nevertheless this disparity in the amounts exchanged came into existence only after three important issues were decided adversely to respondent. The first item charged the bequest of \$35,000 against the husband's share. The second came from the failure to add the automobiles to what respondent received under the will. The final adverse ruling wholly disregarded the possible invasion of the principal of the trust. These elements are not mentioned now to affect the tax due contrary to the determination made below. Their existence, and the difficulty presented, even to the court below, in weighing them provides an obvious explanation why the widow made the deal at all, and why she thought that she had received more than she gave up and had made no gift. It is self evident that the actuarial value of the remainder set in the Tax Court's findings, was not as highly regarded by the widow as the life estate under the will which would produce a nice check every month. In no event can the difference in value, dis-



covered only after judicial construction of the will provisions, change the deal made when the election was signed and filed.

The Commissioner argues that the husband's will only provided a receptacle into which the widow's gift was placed and that some language therein may have "induced" this action; but that the will provisions have no other significance in the case.

The question is simply one of determining whether or not some rule of law exists which requires a disregard of the common sense construction of the transaction arrived at by the trial court. The view adopted by that court is essentially the same as that placed on the agreement by all of the parties at the time, namely, that the widow clearly made her election to get property of great value which was offered to her and available to her only if she would relinquish valuable property rights in her own property.

### **Summary of Argument and Points to Be Urged.**

A. A will requiring an election extends an offer to the widow of a consideration in exchange for the rights which she is asked to relinquish.

B. The evidence shows that the widow accepted a life estate worth \$159,335.43 and a bequest of \$35,000 in exchange for placing her property in trust. The benefits received by the widow substantially offset her transfer and a tax is payable only on the excess value which was a gift.

C. The petitioner has not sustained his burden of showing that the trial court erred.

## ARGUMENT.

### A. A Will Requiring an Election Extends an Offer to the Widow of a Consideration in Exchange for the Rights Which She Is Asked to Relinquish.

It is interesting to note that the present case and *Chase National Bank*, 25 T. C. 617, upon the basis of which the present case was decided, were cases of first impression in the lower court. The use of widow's elections antedates the federal gift tax by many years. Except for a brief period a gift tax has been in effect since 1924.

No attempt was made to subject elections to gift tax for more than thirty years. Obviously long adherence to an erroneous position cannot create any vested interest in its continuance. The former position, however, may have resulted from a recognition of the substantial *quid pro quo* existing in election cases. To the extent that a failure to tax over a period of time builds an administrative construction of the law, and to the extent our analysis of this history is correct, there is a persuasive argument for the proposition that elections are not donative transactions at all.

An examination of the normal widow's election reveals that all of the elements of a regular contract are present. The first requirement, that there be an offer, is supplied by the terms of the will. Page in defining elections and their nature says:

"The gift by will in lieu of the other right is said to be equivalent to an offer, and to offer something to the devisee in return for his property or interest."

*Page on Wills* (Lifetime Ed.), Sec. 1346.

See to the same effect:

*Davis v. Mather* (1923), 309 Ill. 284, 141 N. E. 209;

*Gowling v. Gowling* (1950), 405 Ill. 165, 90 N. E. 2d 188.

It must be remembered that the terms of the will are a unilateral offer. The concepts such as bargaining negotiations and mutual promises pertain only to bilateral contracts. Williston indicates this distinction in saying: "Such statements are true only of bilateral contracts. An offer of reward, an offer of a price for goods, or for services, becomes a contract when what is requested is given or done, though no obligation to give or to do anything ever exists." *Williston on Contracts*, Sec. 13.

Mr. Siegel expressly stated that the provisions in his will for his wife were "in lieu of her community rights and interest and if she elects to take her community interest . . . she shall take nothing . . ." under the will. [R. 28.] This is clearly the language of a contract of exchange. The phrase "in lieu of" means "in the place of" or "instead of." *Webster's New International Dictionary*, (2nd Edition). The word "exchange" has as its most common meaning: "The act of giving or taking one thing in return for another regarded as an equivalent . . ." *Webster's New International Dictionary*, (2nd Edition).

Only bald assertion can read "largess" into the language just quoted where the widow was to receive nothing unless she gave up control over her property. The rights given up as her part of the bargain constituted the alleged gift. The petitioner would have us believe (Pet. Op. Br., p. 8) that the husband was only making a gift to his wife, not offering her a monetary compensation for the release by her of rights valued at \$268,667.98. [R. 37.] On the

record presented, and particularly in view of the testimony of the widow, and the co-executor and co-trustee [R. 74-75, 79-81, 87-91], there is no basis whatever either in law or in fact for so distorting the plain terms of the transaction.

**B. The Evidence Shows That the Widow Accepted a Life Estate Worth \$159,335.43 and a Bequest of \$35,000 in Exchange for Placing Her Property in Trust. The Benefits Received by the Widow Substantially Offset Her Transfer and a Tax Is Payable Only on the Excess Value.**

There is no dispute upon the evidence. The life estate and bequest received by the widow have a value of \$159,335.43 and \$35,000 respectively. [R. 20-21, 30, 35.] The dispute concerns the proper construction of the transaction and is over the question of whether or not the widow received a valuable consideration for her transfer.

The lower court found the existence of a trade or bargain from the specification of a price in the will and the payment of it upon the election. A review of fundamental principles demonstrates that the determination is correct.

Williston has said:

“An offer is to be known from other conditional promises only because the performance of the condition in an offer is requested as the agreed exchange or return for the promise or its performance, thereby giving the offeree a power, by complying with the request, to turn the promise in the offer into a contract or sale. . . . If the offer contemplates the formation of a unilateral contract . . . the offeror proposes to exchange his own promise for an act of the offeree. . . .”

*Williston on Contracts*, Sec. 25

He continues saying:

“If it is said then that a promise has no consideration, the meaning properly is that nothing was in fact given in exchange for the promise or that no action was taken in reliance upon it, either because the promise was intended as a gratuity or because the thing for which it was offered was not given.”

*Williston on Contracts*, Sec. 101.

Before making the election the widow had absolute ownership of a remainder interest valued at \$268,667.98. [R. 37.] She was offered \$194,335.43 if she would place her property in the trust, thus putting the remainder beyond her control. One who has just made a gift would be expected to be poorer by the amount of it. Is the respondent poorer by \$268,667.98? Clearly not, for she received in return, and solely as a part of the single unitary transaction, \$194,335.43 which from her view was more valuable than what she released.

Petitioner suggests that there could be no contract made or consideration demanded or received because the husband is dead. (Pet. Op. Br. p. 8.) Such a view improperly ignores the fact that the will, which contains the offer of the decedent, speaks upon his death and in his place. It is carried out by the executors and trustees who will retain in a representative capacity for the decedent the consideration released by the widow.

“. . . if the promisee parts with something at the promisor's request, it is immaterial whether the promisor receives anything, and necessarily involves the conclusion that the consideration given by the promisee for a promise need not move to the promisor, but may move to any one requested by the offer.”

*Williston on Contracts*, Sec. 113.

The election transaction has long been treated as one of purchase or exchange in cases over the country dealing with abatement of legacies. The rule that legacies acquired for value do not prorate with all legacies but are preferred is explained by Page as follows:

“This result is also justified upon the theory that the legatee for value is a purchaser and not merely the recipient of a gift.”

*Page on Wills*, Sec. 1501.

“One of the more common types of legacy for value is a legacy in lieu of dower, which is generally given priority over other legacies if the assets are insufficient to pay them in full.”

*Page on Wills*, Sec. 1502.

A leading case so holding is *Muse v. Muse* (1947), 186 Va. 914, 45 S. E. 2d 158, 2 A. L. R. 2d 603. In the annotation at page 610 of the *American Law Reports* following the *Muse* case, the rule is stated as follows:

“Although there are cases . . . (to the contrary), the weight of authority is that since it (the election) is in consideration of an existing legal right, it constitutes the widow a purchaser for value and for that reason is entitled to priority over other general legacies or devises to volunteers of the testator’s bounty, which must abate in the widow’s favor.”

Petitioner, however, may argue that even if there were bargaining and consideration in the usual sense, there was no consideration which may be taken into account in a tax case. A suitable answer to this challenge is found in the words of Judge Sibley in *Title Guarantec Loan & Trust Co. v. Comm.* (C. C. A. 5th 1933), 63 F. 2d 621, aff’d 290 U. S. 365, 54 S. Ct. 221. This was an income tax

case. At pages 622 and 623 the judge said respecting a widow's election :

“. . . at the death of her husband this widow had a legal estate in dower . . . and the will in effect made an offer to purchase these from her in consideration of what it gave her ; and that in electing to take under the will she took as a purchaser for value and not as a volunteer. . . . For the sale of her legal rights in her husband's estate she was paid in full by the equitable estate received under the will . . . in the case at bar there was . . . an exchange of legal estates for an equitable estate in an investment.”

Most of the cases cited are from common law jurisdictions and involve elections in lieu of dower. Ordinarily dower is only an expectancy. In contrast, a widow's community property interest, certainly after the husband's death, is vested, and, subject only to administration, is an absolute ownership interest. When a release of a mere expectancy such as dower is sufficient to complete a contract and is treated as a transfer for consideration, obviously an actual conveyance of a vested absolute title in a community property jurisdiction is entitled, if possible, to a more favored treatment. That this would be the rule in California is strongly suggested by *Flanagan v. Capital National Bank* (1931), 213 Cal. 664, 3 P. 2d 307 ; and *Estate of Wyss* (1931), 112 Cal. App. 487, 297 Pac. 100.

This Court passed upon a similar question in *Wells Fargo Bank (Estate of Gibson) v. U. S. A.* (C. C. A. 9th 1957), ..... F. 2d ..... 57-1 USTC. Para. 9653. The Court, in commenting upon the decision in *Lehman v. Comm.* (C. C. A. 2d 1940), 109 F. 2d 99, shows that, in an election case, the husband is the indirect creator of the trust into which he has for a consideration procured a

contribution of property by the wife. The person supplying the property is the real donor to the value of what he provides. *Augustus E. Staley* (1940), 41 BTA 752, Acq. 1942-1 CB 15.

In no event, even on a technical approach, can she be taxed on more than she gave up and the decision below so holding merits the approval of this court. *Estate of Sarah A. Bergan* (1943), 1 T. C. 543, Acq. 1943 C. B. 2.

### C. The Petitioner Has Not Sustained His Burden of Showing That the Trial Court Erred.

The petitioner asserts that the trial court did not distinguish properly between legal consideration and motivation, citing *Philpot v. Gruninger* (1871), 81 U. S. 570, 20 L. Ed. 743. There, in an action on a note, the defense of failure of consideration was offered. On conflicting facts the jury held for the plaintiff. The lower court was affirmed. It was held that since the triers of the facts had found that the parties hadn't bargained for the alleged consideration, errors claimed respecting the defense of failure of consideration did not provide grounds for a reversal.

In our case the facts have been found against petitioner. The plain meaning of the words in the will and the acts called for and performed permit no other reasonable construction but that the widow's transfer was in consideration of her husband's grant of benefits. The learned text writers and numerous courts cited above all reached the same conclusion on similar facts.

When petitioner speaks of the lack of bargaining by the decedent, the largess of the decedent, and the failure of the decedent to regard the act called for as consideration (Pet. Op. Br. pp. 8-9) he cites no language in the will nor any



testimony or other matter in the record to support his allegations. Petitioner misconceives his position. It is his duty on appeal to affirmatively support his allegations of error. If in fact the record is silent, which respondent does not admit, all presumptions in the absence of some contradiction in the record are in favor of the judgment being attacked on appeal. *Grace Bros. Inc. v. Comm.* (C. C. A. 9th 1949), 173 F. 2d 170; *McCarthy Co. v. Comm.* (C. C. A. 9th 1935), 80 F. 2d 618.

Petitioner cites and relies upon five additional cases to establish his points about consideration and elections. A brief reference to each will show that they are not in point.

*Warner v. Comm.* (C. C. A. 2nd 1933), 66 F. 2d 403, *cert. den.* 290 U. S. 688 involved the levy of an income tax on an annuity paid to a widow who had elected to take under a will. The value of the dower interest which she gave up was less than her annuity and she had recovered her "cost." The court held only that the excess she received over the consideration she paid was not obtained by a purchase but was a bequest.

In *Fire Insurance Ass'n v. Wickham* (1891), 141 U. S. 564, the court held that parol evidence was admissible to vary a written contract to show the parties had not in fact bargained for a particular item as consideration.

The court held in *Comm. v. McLean* (C. C. A. 5th 1942), 127 F. 2d 942, that a taxpayer claiming two trusts were created in consideration of each other had the burden of offering evidence in support of the contention. Also when all of the facts concerning the transaction were exclusively in his knowledge and possession and no evidence was offered on the point, his silence would be construed against his position.

The evidence in *Giannini v. Comm.* (C. C. A. 9th 1945), 148 F. 2d 285 *cert. den.* 326 U. S. 730, showed that the individual who in the trial was claimed to have put property in a trust in consideration of a much larger contribution by his parents had, in a contemporaneous writing, accepted the "gift" from his parents.

The petitioner's citation from *McFarland v. Campbell* (C. C. A. 5th 1954), 213 F. 2d 855, is admittedly *dicta*. It seems to us, however, from a reading of the opinion that its purport is that you need a *quid pro quo* to raise an election situation, and that if a benefit had been offered and in return an immediate transfer or relinquishment had occurred, a true election would have been present.

### Conclusion.

No case cited by petitioner is authority either by direct holding or in *dicta* for the proposition that to the extent that the considerations on both sides of the usual election transaction balance, a gift occurred instead of an exchange. The Tax Court has twice held against petitioner on logical and equitable reasoning. This court should affirm the decision so holding in the present proceedings.

Respectfully submitted,

DANA LATHAM,  
A. R. KIMBROUGH,  
HENRY C. DIEHL,  
GROVER HEYLER,

*Attorneys for Respondent.*

No. 15433

---

---

United States  
Court of Appeals  
for the Ninth Circuit

---

CONTAINER CORPORATION OF AMERICA,  
a corporation, Appellant,

vs.

M. C. S. CORPORATION, Appellee.

---

Transcript of Record

---

Appeal from the United States District Court for the  
Southern District of California,  
Central Division

FILED

APR 10 1957

PAUL P. O'BRIEN, CLERK



No. 15433

---

---

United States  
Court of Appeals  
for the Ninth Circuit

---

CONTAINER CORPORATION OF AMERICA,  
a corporation, Appellant,

vs.

M. C. S. CORPORATION, Appellee.

---

Transcript of Record

---

Appeal from the United States District Court for the  
Southern District of California,  
Central Division

---

---



## INDEX

[Clerk's Note: When deemed likely to be of an important nature, errors or doubtful matters appearing in the original certified record are printed literally in *italic*; and, likewise, cancelled matter appearing in the original certified record is printed and cancelled herein accordingly. When possible, an omission from the text is indicated by printing in *italic* the two words between which the omission seems to occur.]

	PAGE
Answer and Counterclaim.....	5
Answer to Plaintiff's Interrogatories (Ex. 15)	22
Appeal:	
Certificate of Clerk to Transcript of Record on .....	37
Designation of Record on (DC).....	35
Notice of .....	31
Order for Transmission of Original Exhibits on .....	36
Statement of Points and Designation of Record on (USCA).....	195
Statement of Points on (DC).....	33
Stipulation for Costs on.....	32
Certificate of Clerk to Transcript of Record...	37
Complaint .....	3
Designation of Record on Appeal (DC).....	35
Adoption of (USCA).....	195
Findings of Fact, Conclusions of Law and Judgment .....	28

Interrogatories by Plaintiff (Ex. 14).....	19
Names and Addresses of Attorneys.....	1
Notice of Appeal.....	31
Notice of Decision.....	26
Notice of Withdrawal as Attorneys for Defendant-Appellee (USCA) .....	194
Notice Pursuant to Title 35, U.S.C. Section 282	15
Order for Transmission of Original Exhibits..	36
Reply to Counterclaim.....	14
Requests for Admissions of Fact, Plaintiff's (Ex. 7) .....	16
Statement of Points on Appeal (DC).....	33
Adoption of (USCA).....	195
Stipulation for Costs on Appeal.....	32
Submission of Document Pursuant to Proffer Made During Trial, Defendant's.....	25
Transcript of Proceedings and Testimony.....	39
Exhibits for Plaintiff:	
7—Requests for Admissions of Fact, Plaintiff's .....	16
Admitted in Evidence.....	43
14—Interrogatories by Plaintiff.....	19
Admitted in Evidence.....	45
15—Answers to Interrogatories by Plain- tiff .....	22
Admitted in Evidence.....	46



## Transcript of Proceedings—(Continued):

## Witnesses:

Comstock, Robert C.

—direct ..... 153

—cross ..... 182

Poole, William J.

—direct (Plaintiff) ..... 46

—cross ..... 87

—direct (Defendant) ..... 124

—cross ..... 149

—redirect ..... 151



## NAMES AND ADDRESSES OF ATTORNEYS

For Appellant:

J. CALVIN BROWN,

704 So. Spring St.,  
Los Angeles 14, California,

BROWN, JACKSON, BOETTCHER AND  
DIENNER,

53 W. Jackson Blvd.,  
Chicago 4, Illinois. [1]\*

---

\* Page numbers appearing at foot of page of original Transcript of Record.



In The United States District Court, Southern  
District of California, Central Division

Civil Action No. 16413-T

CONTAINER CORPORATION OF AMERICA,  
Plaintiff,

v.

M. C. S. CORPORATION, Defendant.

COMPLAINT FOR INFRINGEMENT OF  
LETTERS PATENT NO. 2,638,261

Equitable Relief Sought

1. Container Corporation of America, a corporation organized and existing under and by virtue of the laws of the State of Delaware, having its corporate office at Wilmington, Delaware, and its general office at Chicago, Illinois, brings this, its Complaint, against the M.C.S. Corporation, a corporation organized and existing under and by virtue of the laws of the State of California, having its principal place of business at Los Angeles, California.

The jurisdiction of this Court is based upon the following:

(a) This is an action arising under the patent laws of the United States, in which [2] plaintiff seeks an injunction and an accounting.

(b) Defendant, M.C.S. Corporation, is an inhabitant of the Southern District of California, Central Division, has a regular and established place of

business within the Southern District of California, Central Division, and has committed acts of patent infringement, hereinafter complained of, within the Southern District of California, Central Division.

2. On May 12, 1953, United States Letters Patent No. 2,638,261 were duly and legally issued to plaintiff, Container Corporation of America, for an invention in Frozen Food Carton With Plastic Lid; and, since that date, plaintiff, Container Corporation of America, has been, and still is, the owner of said Letters Patent No. 2,638,261.

3. Defendant, M. C. S. Corporation, has been, and still is, infringing the aforesaid letters patent, by making, using, and/or selling plastic lids for frozen food cartons embodying the invention patented in and by said letters patent, and will continue to do so unless enjoined by this Court.

Wherefore, plaintiff demands an injunction against further such infringement by defendant and those controlled by defendant, an accounting for damages, and an assessment of costs against defendant.

CONTAINER CORPORATION OF  
AMERICA,

/s/ By J. CALVIN BROWN,  
Attorney for Plaintiff.

/s/ ARTHUR H. BOETTCHER,  
Of Counsel.

[Endorsed]: Filed Feb. 25, 1954. [3]

[Title of District Court and Cause.]

## ANSWER AND COUNTERCLAIM

Defendant, M.C.S. Corporation, for its answer to the complaint alleges, avers, and denies as follows:

### I.

Answering Paragraph 1 of the complaint, the defendant

(a) Admits that it is a California corporation having its principal place of business at Los Angeles, California;

(b) Admits that it is an inhabitant of the Southern District of California, Central Division, and has a regular and established place of business within the Southern District of California, Central Division; [4]

(c) Admits that the jurisdiction of this Court is based upon and arises under the Patent Laws of the United States;

(d) Denies that it has committed acts of patent infringement complained of in the complaint, within the Southern District of California, Central Division, or at any other place;

(e) Alleges that it is without knowledge or information sufficient to form a belief as to the truth of each and every remaining allegation of said Paragraph 1.

### II.

Answering Paragraph 2 of the complaint, the defendant admits that United States Letters Patent No. 2,638,261 was issued on May 12, 1953, to Con-

tainer Corporation of America; denies that said Letters Patent was duly or legally issued; denies that said Letters Patent was issued for an invention in Frozen Food Carton With Plastic Lid, or for any other invention; and alleges that it is without knowledge or information sufficient to form a belief as to the truth of the remaining allegations of said Paragraph 2.

### III.

Answering Paragraph 3 of the complaint, the defendant denies that it has, or at any time past has, been, and denies that it is now, infringing said Letters Patent by making, using, and/or selling plastic lids for frozen food cartons alleged to embody the invention alleged to be patented, or that it is otherwise infringing said Letters Patent, and denies that it will, unless enjoined by this Court, infringe said Letters Patent. [5]

Further Answering Plaintiff's Complaint With Respect to the Claim or Cause of Action For Patent Infringement Alleged In Paragraphs 1 through 3 Thereof, and For Separate, Alternate, and Further Defenses Thereto, The Defendant Avers As Follows:

### IV.

The defendant has not infringed Letters Patent No. 2,638,261 or any claim or claims thereof.

### V.

The alleged inventions or discoveries claimed in Letters Patent No. 2,638,261 were not patentable to the alleged inventor named therein, under the



provisions of Section 4886 of the Revised Statutes of the United States [35 U.S.C. (1952), Sections 101 and 102], and therefore said patent is, and each and every claim thereof is, invalid and void.

#### VI.

All the claims of Letters Patent No. 2,638,261 are, and each of them is, invalid and void, because the alleged inventions or discoveries described thereby were patented or described in certain printed publications and Letters Patent in this and foreign countries before the alleged invention or discovery thereof by the applicant for said Letters Patent, the Letters Patent, the numbers thereof, the names of the patentees thereof, and the dates of said Letters Patent or publications which are at this time unknown to the defendant, who prays leave to plead the same by amendment to this answer when they are ascertained.

#### VII.

All the claims of Letters Patent No. 2,638,261 are, and each of them is, invalid, because prior to any supposed [6] invention or discovery by the applicant for said Letters Patent, that which is alleged to be patented by said Letters Patent, and particularly that which is described and claimed therein, and all material and substantial parts thereof, had been known to, and used by, others in this country.

#### VIII.

All the claims of Letters Patent No. 2,638,261, and each of them is, invalid, because the applicant

for said Letters Patent was not the original or first inventor of any material or substantial part of that which is purported to be patented in said Letters Patent, and the same thing or things in all material and substantial respects had, prior to the alleged inventions or discoveries thereof by the applicant for said Letters Patent, been invented or discovered (if there be any patentable invention or discovery defined by any of said claims) by others.

## IX.

All the claims of Letters Patent No. 2,638,261 are, and each of them is, invalid, because the alleged invention and discoveries purportedly defined by the claims of said Letters Patent were in public use or on sale in this country for more than one (1) year prior to the application date of said Letters Patent.

## X.

All the claims of Letters Patent No. 2,638,261 are, and each of them is, invalid, because the alleged Letters Patent fails to comply with Section 4888 of the Revised Statutes of the United States [35 U.S.C. (1952), Sections 111 and 112], and in particular in failing to particularly point out and distinctly claim the parts, improvements or combinations alleged to constitute the invention or discovery of said Letters Patent. [7]

## XI.

All the claims of Letters Patent No. 2,638,261 are, and each of them is, invalid, because in view of the state of the art as it existed at the time of, and

long prior to, the date of the alleged invention or discovery claimed in said Letters Patent, said Letters Patent does not claim any invention or discovery, and does not involve any invention or discovery or contain any patentable novelty, but consists of the mere adoption of well-known devices for the required uses involving ordinary faculties of reasoning and the skill expected of one in the art to which said Letters Patent pertains, said state of the art including the prior patents and publications referred to in Paragraph VI herein and others for which this defendant is diligently searching, leave and permission of this Honorable Court being requested to set them forth herein by amendment when they are ascertained.

## XII.

All the claims of Letters Patent No. 2,638,261 are, and each of them is, invalid, because said Letters Patent was not granted or issued by the Commissioner of Patents regularly or within the authority granted him under due form of law or after due proceedings were had with respect to the application filed by or on behalf of the applicant therefor, and because the Commissioner of Patents did not cause a proper examination to be made as to the alleged invention or discovery purportedly defined by said Letters Patent, and had such an examination been made properly it would have appeared that the applicant for said Letters Patent was not entitled thereto, and that said Letters Patent would not have been issued, and that said Letters Patent was irregularly granted without proper or due con-

sideration of the application for the same and without fulfillment of the necessary requirements of the Patent Office Examiner in searching the Patent Office records [8] available to him prerequisite to granting of said Letters Patent.

### XIII.

All the claims of Letters Patent No. 2,638,261 are, and each of them is, invalid, because each of the claims defines merely an old combination of elements which operate in substantially the same way to produce substantially the same result as they did individually in the prior art.

### XIV.

All the claims of Letters Patent No. 2,638,261 are, and each of them is, invalid, because each of said claims includes more than that which was disclosed in said Letters Patent, and more than that which is purported to have been invented, and because in each of said claims the language thereof is too broad at the precise alleged point of novelty (if there be any novelty).

### XV.

All the claims of Letters Patent No. 2,638,261 are, and each of them is, invalid, because the alleged invention or discovery purportedly defined by said claims, and each of them, are not in fact inventions or discoveries but are the same aggregation of old and unpatentable elements not amounting to patentable combination.

### XVI.

In view of the state of the art at and before the

alleged invention or discovery of Letters Patent No. 2,638,261, or attempted to be defined in any claim of said Letters Patent, said claims, or any of them, cannot now be given an interpretation, meaning or scope to cover, include or bring within the purview thereof, any device made by the defendant.

### XVII.

While the application for Letters Patent No. 2,638,261 was pending in the Patent Office, the applicant therefor so limited and confined the disclosure and claims of said application under the requirement of the Commissioner of Patents, or otherwise, that the plaintiff cannot now seek or obtain a construction of any of the claims of said Letters Patent sufficiently broad to cover or embrace any devices made by the defendant.

For A Counterclaim Against The Plaintiff, Container Corporation of America, The Defendant Avers As Follows:

#### A.

Defendant-counterclaimant, M.C.S. Corporation, is a corporation organized and existing under the laws of the State of California and having its principal place of business in Los Angeles, California.

#### B.

Plaintiff-counterdefendant, Container Corporation of America, admits by Paragraph 1 of its complaint herein that it is a corporation organized and existing under and by virtue of the laws of the State of Delaware, having its corporate office at Wilmington, Delaware, and its general office at

Chicago, Illinois. This counterclaim arises under Section 2201 of Title 28 of the United States Code because there is an actual controversy now existing between the counterclaimant and the counterdefendant in respect of which the counterclaimant needs a declaration of its rights by this Court, which controversy arises over the question of validity and infringement of United States Letters Patent No. 2,638,261, and each and every of the claims thereof, alleged [10] to be owned by the plaintiff-counterdefendant, Container Corporation of America, in that plaintiff-counterdefendant has charged defendant-counterclaimant with infringement of said Letters Patent.

### C.

The alleged invention or discovery of United States Letters Patent No. 2,638,261 is, and each and every claim thereof is, invalid and void, irrespective of any alleged infringement thereof by defendant-counterclaimant, and defendant-counterclaimant needs a declaratory judgment of invalidity and unenforceability of said Letters Patent, and each and every of the claims thereof, on the grounds set forth herein as a means of relief to it and the public at large.

### D.

Defendant-counterclaimant adopts, repeats and realleges as Paragraphs D to Q, inclusive, of this counterclaim, each and every one of the allegations contained in Paragraphs IV to XVII, inclusive, of the foregoing answer with like effect as if fully repeated herein.

Wherefore, the defendant and counterclaimant prays as follows:

(1) That the complaint be dismissed with prejudice;

(2) That United States Letters Patent No. 2,638,261, and each and every of the claims thereof, be declared not infringed by any act of the defendant and counterclaimant;

(3) That United States Letters Patent No. 2,638,261, and each and every claim thereof, be declared and adjudged invalid, void and unenforceable;

(4) That the defendant and counterclaimant recover from the plaintiff and counterdefendant its costs and disbursements herein and reasonable attorneys' fees; and

(5) That the defendant and counterclaimant be granted such other and further relief as may be proper.

Dated: At Los Angeles, California, this 8th day of April, 1954.

HARRIS, KIECH, FOSTER &  
HARRIS,  
DONALD C. RUSSELL,  
WARREN L. KERN,

/s/ By DONALD C. RUSSELL,  
Attorneys for M.C.S. Corporation.

Acknowledgment of Service Attached. [13]

[Endorsed]: Filed April 8, 1954.

[Title of District Court and Cause.]

## REPLY TO COUNTERCLAIM

Now comes the plaintiff, Container Corporation of America, and, for its reply to defendant's Counterclaim, states:

A.

Plaintiff admits the allegations of Paragraph A of said Counterclaim.

B.

As to Paragraph B of said Counterclaim, plaintiff admits that it is a corporation organized and existing under and by virtue of the laws of the State of Delaware, having its corporate office at Wilmington, Delaware, and its general office at Chicago, Illinois; but it denies any need for the said [14] counterclaim because the issues presented by it are already joined by the Complaint and Answer.

C.

Plaintiff denies each and every allegation contained in Paragraph C of said Counterclaim.

D.

Plaintiff denies each and every allegation contained in Paragraph D of said Counterclaim, denying each and every allegation contained in Paragraphs IV to XVII, inclusive, of defendant's Answer, incorporated by said Paragraph D as Paragraphs D to Q, inclusive, of said Counterclaim.

Wherefore, plaintiff denies that there is any ground for any judgment, decree, declaration or



order as prayed by defendant, and prays that said Counterclaim be dismissed with costs to plaintiff.

CONTAINER CORPORATION OF  
AMERICA,

/s/ By J. CALVIN BROWN,  
Attorney for Plaintiff.

/s/ HENRY H. BABCOCK,  
/s/ ARTHUR H. BOETTCHER,  
Of Counsel. [15]

Acknowledgment of Service Attached. [16]

[Endorsed]: Filed April 24, 1954.

---

[Title of District Court and Cause.]

NOTICE PURSUANT TO TITLE 35, U.S.C. § 282

To: Container Corporation of America, Plaintiff,  
and to Brown, Jackson, Boettcher & Dienner  
and J. Calvin Brown, Its Counsel:

Please Take Notice that the defendant, M.C.S. Corporation, will rely upon one or more of the following identified patents, publications, persons in support of the defenses pleaded and the allegations stated in the Answer and Counterclaim of M.C.S. Corporation. [127]

Patent No.	Date Issued	Patentee	Country
1,969,486	Aug. 7, 1934	Kurz	United States
2,399,241	Apr. 30, 1946	Merkle	United States
2,381,508	Aug. 7, 1945	Moore	United States
2,155,022	Apr. 18, 1939	Rutkowski	United States
1,325,930	Dec. 23, 1919	Drake	United States

Patent No.	Date Issued	Patentee	Country
2,392,959	Jan. 15, 1946	Van Saun	United States
2,623,685	Dec. 30, 1952	Hill	United States

Persons

William J. Poole, of Container Corporation of America.

Dated: At Los Angeles, California, this 10th day of October, 1955.

HARRIS, KIECH, FOSTER &  
HARRIS,  
DONALD C. RUSSELL,  
WARREN L. KERN,  
/s/ By DONALD C. RUSSELL,  
Attorneys for M.C.S. Corporation.

Affidavit of Service by Mail Attached. [129]

[Endorsed]: Filed Oct. 11, 1955.

---

[Title of District Court and Cause.]

PLAINTIFF'S EXHIBIT No. 7

PLAINTIFF'S REQUESTS FOR ADMISSIONS  
OF FACT

Now comes plaintiff, Container Corporation of America, by its undersigned attorney, and, in accordance with the provisions of Rule 36 of the Federal Rules of Civil Procedure, requests that defendant, M S C Corporation, admit the following facts on or before April 9th, 1956.

No. 1

Since the issuance of the patent in suit, United

States Letters Patent No. 2,638,261, and prior to the filing of the Complaint herein, defendant manufactured or caused to be manufactured, and sold or caused to be sold, within and from the Southern District of California, lids for cartons for frozen foods, of which the following are specimens: Lid marked for identification "Plaintiff's [132] Exhibit Specimen of Accused Lid, Large Size", and lid, marked for identification "Plaintiff's Exhibit Specimen of Accused Lid, Small Size", which specimens are delivered to defendant's attorney herewith and are to be returned to plaintiff's attorney at the time of defendant's response to these Requests for Admissions, for custody until time of trial, available to defendant's attorney.

No. 2

That, since the issuance of the patent in suit, United States Letters Patent No. 2,638,261, and prior to the filing of the Complaint herein, defendant caused to be printed and issued, within and from the Southern District of California, literature of which the following are specimens: Sheets marked for identification "Plaintiff's Exhibit Specimen of Defendant's Literature #1" and "Plaintiff's Exhibit Specimen of Defendant's Literature #2", respectively, which specimens are delivered to defendant's attorney herewith and are to be returned to plaintiff's attorney at the time of defendant's response to these Requests for Admissions, for custody until time of trial, available to defendant's attorney.

## No. 3

That, since the issuance of the patent in suit, United States Letters Patent No. 2,638,261, and prior to the filing of the Complaint herein, defendant placed an advertisement in the periodical entitled "Locker Management" which appeared in the January, 1953, issue of said periodical, copy of which advertisement, marked for identification "Plaintiff's Exhibit Defendant's Advertisement", is delivered to defendant's attorney herewith and is to be returned to plaintiff's attorney at the time of defendant's response to these Requests for Admissions, for [133] custody until time of trial, available to defendant's attorney.

## No. 4

That "Ree-Seal" and "Ree Seal Company" are adopted names under which M C S Corporation, defendant herein, has been doing business with which this case is concerned.

## No. 5

That, on or about November 5, 1953, defendant received a letter of which the letter marked for identification "Plaintiff's Exhibit, Copy of Letter of Notification" is a copy, said copy being delivered to defendant's attorney herewith, to be returned to plaintiff's attorney at the time of defendant's response to these Requests for Admissions, for custody until time of trial, available to defendant's attorney.

Dated: Los Angeles, California, March 28, 1956.

/s/ J. CALVIN BROWN,  
Attorney for Plaintiff.

/s/ ARTHUR H. BOETTCHER,  
Of Counsel. [134]

Acknowledgment of Service Attached. [136]

[Endorsed]: Filed March 28, 1956.

---

[Title of District Court and Cause.]

PLAINTIFF'S EXHIBIT No. 14

INTERROGATORIES BY PLAINTIFF

Now comes plaintiff, Container Corporation of America, by its undersigned attorney, and, in accordance with the provisions of Rule 33 of the Federal Rules of Civil Procedure, files the following interrogatories :

1.

Give the names and residence addresses of all officers, directors and managing agents of the defendant.

2.

Was one Donald Frederick ever an officer, director or managing agent of the defendant? [137]

3.

If the answer to preceding Interrogatory 2 is in the affirmative, state in what capacity he was connected with the defendant and the period of time

during which he acted in such capacity, and give his residence address.

4.

When did defendant begin to manufacture or cause to be manufactured lids for cartons for frozen foods such as the lids exemplified by the physical exhibits submitted with Plaintiff's Requests for Admissions of Fact filed concurrently herewith?

5.

Is defendant presently manufacturing or causing to be manufactured lids such as identified in preceding Interrogatory 4?

6.

If the answer to preceding Interrogatory 5 is in the negative, state when defendant ceased to manufacture or caused to be manufactured such lids.

7.

When did defendant begin selling or causing to be sold such lids such as identified in preceding Interrogatory 4?

8.

When, prior to the service of these interrogatories, did defendant last sell or cause to be sold any lids such as identified in preceding Interrogatory 4? [138]

9.

Give the name and address of the customer who purchased the lids referred to in the answer to preceding Interrogatory 8 and state the number of lids involved in the transaction.

10.

When, prior to the service of these interrogatories, did defendant last advertise to the trade lids such as identified in preceding Interrogatory 4?

11.

If the advertisement referred to in the answer to preceding Interrogatory 10 was in a periodical, state its name and date and the name and address of its publisher.

12.

Is the defendant at the present time actively engaged in the business of making or having made and selling or causing to be sold lids for cartons for frozen foods.

13.

What is the present address of defendant's place of business?

Dated: Los Angeles, California, March 28, 1956.

/s/ J. CALVIN BROWN,  
Attorney for Plaintiff.

/s/ ARTHUR H. BOETTCHER,  
Of Counsel. [139]

Acknowledgment of Receipt of Copy Attached.

[Endorsed]: Filed March 28, 1956.

[Title of District Court and Cause.]

PLAINTIFF'S EXHIBIT No. 15

ANSWER TO INTERROGATORIES  
BY PLAINTIFF

Now comes the defendant, M C S Corporation, and through one of its officers, Henry F. Bloomfield, Jr., answers the Interrogatories by Plaintiff as follows:

Interrogatory 1: "Give the names and residence addresses of all officers, directors and managing agents of the defendant."

Answer: Henry F. Bloomfield, Jr., 921 N. Rexford Drive, Beverly Hills, California; William A. Bloomfield, 1104 Tower Road, Beverly Hills, California; [143] Donald Frederick, Route #1, Box 240, Saugus, California.

Interrogatory 2: "Was one Donald Frederick ever an officer, director or managing agent of the defendant?"

Answer: Yes.

Interrogatory 3: "If the answer to preceding Interrogatory 2 is in the affirmative, state in what capacity he was connected with the defendant and the period of time during which he acted in such capacity, and give his residence address."

Answer: Since the incorporation of the defendant, M C S Corporation, Mr. Frederick has been vice president of the defendant corporation; and upon information and belief his residence address is Route #1, Box 240, Saugus, California.



Interrogatory 4: "When did defendant begin to manufacture or cause to be manufactured lids for cartons for frozen foods such as the lids exemplified by the physical exhibits submitted with Plaintiff's Requests for Admissions of Fact filed concurrently herewith?"

Answer: March 9, 1951.

Interrogatory 5: "Is defendant presently manufacturing or causing to be manufactured lids such as identified in preceding Interrogatory 4?" [144]

Answer: Yes.

Interrogatory 6: "If the answer to preceding Interrogatory 5 is in the negative, state when defendant ceased to manufacture or caused to be manufactured such lids."

Answer: No answer required.

Interrogatory 7: "When did defendant begin selling or causing to be sold lids such as identified in preceding Interrogatory 4?"

Answer: March 9, 1951.

Interrogatory 8: "When, prior to the service of these interrogatories, did defendant last sell or cause to be sold any lids such as identified in preceding Interrogatory 4?"

Answer: On or about March 26, 1956.

Interrogatory 9: "Give the name and address of the customer who purchased the lids referred to in the answer to preceding Interrogatory 8 and state the number of lids involved in the transactions."

Answer: Frances Abraham of Arkadelphia, Arkansas; 20 lids. [145]

Interrogatory 10: "When, prior to the service of

these interrogatories, did defendant last advertise to the trade lids such as identified in preceding Interrogatory 4?"

Answer: The defendant advertised in the January, 1953, issue of Locker Management, but is not presently advised of the date of its last advertisement to the trade.

Interrogatory 11: "If the advertisement referred to in the answer to preceding Interrogatory 10 was in a periodical, state its name and date and the name and address of its publisher.

Answer: Upon information and belief the last advertisement was in the publication Locker Management; and on information and belief the name and address of the publisher is Locker Management, Inc., St. Louis 2, Missouri.

Interrogatory 12: "Is the defendant at the present time actively engaged in the business of making or having made and selling or causing to be sold lids for cartons for frozen foods?"

Answer: Yes.

Interrogatory 13: "What is the present address of defendant's place of business?"

Answer: 1120 North La Brae Avenue, Los Angeles, California.

/s/ HENRY F. BLOOMFIELD,  
JR. [146]

Duly Verified. [147]

Acknowledgment of Receipt of Copy Attached.

[Endorsed]: Filed Apr. 17, 1956.

[Title of District Court and Cause.]

DEFENDANT'S SUBMISSION OF DOCUMENT PURSUANT TO PROFFER MADE DURING TRIAL

Pursuant to the proffer into evidence by counsel for the defendant during the time of trial of the above identified cause (on Friday, May 4, 1956; see Reporter's Transcript of Proceedings, pages 129-130) of the File Wrapper and Contents of United States Letters Patent to Hill No. 2,623,685, the defendant hereby submits to this Honorable Court the following identified documents respecting said patent which are filed concurrently herewith and marked Defendant's Exhibits H and I.

Defendant's Exhibit H

A Certified true copy from the records of the United States Patent Office of the File Wrapper and Contents of United States Letters Patent No. 2,623,685 to Donald W. Hill, for Plastic Cover for Waxed Paper Container. [203]

Defendant's Exhibit I

A Certified true copy from the records of the United States Patent Office of United States Letters Patent No. 2,623,685 to Donald W. Hill, for Plastic Cover for Waxed Paper Container.

Defendant's Exhibit I is a certified copy of United States Letters Patent to Donald W. Hill, an uncertified copy having been submitted during the trial as Tab 7 of Defendant's Exhibit B.

Respectfully submitted,

HARRIS, KIECH, FOSTER  
& HARRIS,

/s/ By DONALD C. RUSSELL [204]

Affidavit of Service by Mail Attached. [205]

[Endorsed]: Filed May 23, 1956.

---

[Title of District Court and Cause.]

### NOTICE OF DECISION

In this action brought to redress a claim of infringement of United States Letters Patent to Poole (No. 2,638,261), the Court is asked first to determine validity of the patent and, second, to find that defendant's structure infringes.

There are six claims in the Poole patent, all of which are involved.

The patent discloses:

“—a paperboard open top carton (12) having a lap joint (17 and 13) extending to the upper edge of the carton, and

—a cover (11) having a peripheral [287] downwardly extending recess (18) for engagement with the open top of the carton, the recess being made twice as wide (18) at the lap joint to fit the double thickness of the carton wall due to the lap joint (See Fig. 4 of Poole).”

The paper bound carton is certainly not new nor does the lap joint have any novelty.

Plaintiff contends that there is a combination of

elements which co-related and viewed as a whole unit produce a different effect from the sum of that which is produced by their separate parts. As this is consistent with the applicable rule, it is not necessary that any one of the several elements in itself be new.

As has been said by the Court of Appeals for this Circuit:<sup>1</sup>

“A new combination of old elements, in which, by a different location of one or more of the elements, a new and useful result is attained, or an old result is produced in a better way, is patentable. \* \* \*”

This rule does not do away with the necessity that the effective combination perform some new or different function than the various elements performed in their prior public uses, and that the patentee has, by his new combination, created something new that has not existed before. The new thing must have been produced by [288] “invention” as distinguished from mere mechanical skill.

The Court is convinced that any reasonably competent person skilled in the art, if presented with the problem of providing a cover for a lap-jointed carton, could have produced what Poole produced and, in so doing, would not have gone beyond the simple skills known and practiced in the art.

The Court finds that the structure is wanting in invention. It is the result of the application of ordinary structural skill or, as the books put it, “mechanical skill.”

---

<sup>1</sup>New York Scaffolding Co. v. Whitney, 224 F. 452, at 458.

As this finding makes it unnecessary to find further, the Court will not discuss the prior patents or the similarity of the accused structure.

Counsel for defendant will submit Findings, Conclusions and Judgment consonant with this Notice of Decision.

Dated: This 7th day of November, 1956.

/s/ ERNEST A. TOLIN,  
United States District Judge. [289]

[Endorsed]: Filed Nov. 7, 1956.

---

In the United States District Court, Southern  
District of California, Central Division

Civil Action No. 16,413-T

CONTAINER CORPORATION OF AMERICA,  
Plaintiff,

v.

MCS CORPORATION,                      Defendant.

FINDINGS OF FACT, CONCLUSIONS OF  
LAW, AND JUDGMENT

Findings of Fact

1. The plaintiff, Container Corporation of America, is a corporation organized and existing under and by virtue of the laws of the State of Delaware, having its corporate office at Wilmington, Delaware, and its general office at Chicago, Illinois.

2. The defendant, M C S Corporation, is a California corporation having its principal place of business at Los Angeles, California.

3. This action is based upon the patent laws of the United States, and the counterclaim arises under the patent laws [291] of the United States and Section 2201 of Title 28 of the United States Code.

4. The plaintiff, Container Corporation of America, is the owner of the United States Letters Patent No. 2,638,261, in suit, said patent having been issued to the plaintiff on May 12, 1953, on an application, Serial No. 26,172, filed on May 10, 1948, by William J. Poole for the Frozen Food Carton With Plastic Lid.

5. The patent in suit, No. 2,638,261, discloses a paper board open top carton having a lap joint extending to the upper edge of the carton, and a cover having a peripheral downwardly extending recess for engagement with the open top of the carton, the recess being made twice as wide at the lap joint to fit the double thickness of the carton wall due to the lap joint.

6. The patent in suit and each and every claim thereof relates to a combination of old elements, which combination could have been produced by any reasonably competent person skilled in the art without going beyond the simple skills known and practiced in the art.

7. The structure as claimed in each and every claim of the patent in suit is wanting in invention.

### Conclusions of Law

1. The court has jurisdiction of the parties and over the subject matter set forth in the complaint, and the court has jurisdiction of the parties and over the subject matter set forth in the counterclaim. [292]

2. Each of the claims, 1, 2, 3, 4, 5 and 6 of the patent in suit, No. 2,638,261, in issue herein, is invalid and void for lack of invention.

3. The defendant, M C S Corporation, is entitled to judgment against the plaintiff, Container Corporation of America, dismissing the complaint with prejudice.

4. The defendant, M C S Corporation, is entitled to judgment on its counterclaim herein for declaratory relief, adjudging the patent in suit No. 2,638,261, and each and every of the claims thereof, invalid and void.

### Judgment

In accordance with the foregoing Findings of Fact and Conclusions of Law, it is ordered, adjudged and decreed that:

1. United States Letters Patent No. 2,638,261 and each and every claim thereof, is invalid and void in law.

2. The Complaint for Infringement of United States Letters Patent No. 2,638,261 is hereby dismissed with prejudice.

3. The Counterclaim for declaratory relief ad-



judging United States Letters Patent No. 2,638,261 and each and every of the claims thereof, invalid and void, is hereby sustained.

4. The defendant, M C S Corporation, is entitled to recover from the plaintiff, Container Corporation of America, [293] its costs herein in the amount of \$49.10.

Dated: This 20th day of November, 1956.

/s/ ERNEST A. TOLIN,

United States District Judge. [294]

Acknowledgment of Receipt of Copy attached. [295]

[Endorsed]: Lodged Nov. 13, 1956. Docketed, Entered and Filed Nov. 20, 1956.

---

[Title of District Court and Cause.]

### NOTICE OF APPEAL

Notice is hereby given that Container Corporation of America, plaintiff above named, hereby appeals to the United States Court of Appeals for the Ninth Circuit from the judgment entered in this action on the 20th day of November, 1956.

Dated: December 17, 1956.

/s/ J. CALVIN BROWN,

Attorney for Plaintiff. [297]

[Endorsed]: Filed Dec. 17, 1956.

[Title of District Court and Cause.]

### STIPULATION FOR COSTS ON APPEAL

Know All Men By These Presents, That Fidelity and Deposit Company of Maryland, a Corporation organized and existing under the laws of the State of Maryland, and duly licensed to transact business in the State of California, is held and firmly bound unto M.C.S. Corporation on the penal sum of Two Hundred and Fifty and No/100 (\$250.00) Dollars, to be paid to said Defendant, his successors, assigns or legal representatives, for which payment well and truly to be made, the Fidelity and Deposit Company of Maryland binds itself, its successors and assigns firmly by these presents.

The Condition of the Above Obligation Is Such, that whereas, Container Corporation of America is about to take an appeal to the United States Court of Appeals for the Ninth Circuit appealing from a decree dated November 20, 1956 finding non infringement of a certain patent by the United States District Court for the Southern District of California, Central Division, in the above entitled case.

Now, Therefore, if the above named appellant shall prosecute said appeal to effect and answer all costs which may be adjudged against it if it fails to make good its appeal, then this obligation shall be void; otherwise to remain in full force and effect. [298]

It Is Further Agreed by the Surety, that in case of default or contumacy on the part of the Principal or Surety, the Court may, upon notice to them

of not less than ten days, proceed summarily and render judgment against them, or either of them, in accordance with their obligation and award execution thereon.

Signed, Sealed, and dated this 13th day of December, 1956.

[Seal] FIDELITY AND DEPOSIT COMPANY OF MARYLAND,  
/s/ By ROBERT HECHT,  
Attorney in Fact.

Examined and recommended for approval as provided in Rule 8.

/s/ J. CALVIN BROWN,  
Attorney.

Approved this 17th day of December, 1956.

/s/ M. E. THOMPSON,  
Deputy.

Duly Verified. [299]

[Endorsed]: Filed Dec. 17, 1956.

---

[Title of District Court and Cause.]

### STATEMENT OF POINTS

1. The District Court, weighing the subject matter of the patent in suit for invention, erred in taking into account only the lap joint of the open-top carton and the widening of the under-side peripheral recess of the cover to accommodate the double thickness of the lap.

2. The District Court, weighing the subject matter of the patent in suit for invention, erred in not taking into account all the recitations in each of the claims of the patent in suit.

3. The District Court, weighing the subject matter of the patent in suit for invention, erred in not treating the same as a patentable combination of the elements as specified in the claims.

4. The District Court erred in finding the structure [300] of the patent in suit wanting in invention and in finding that producing it involved no more than ordinary skill of the art.

5. The District Court erred in holding the patent in suit invalid and void, in dismissing the complaint, in sustaining defendant's counterclaim, and in awarding costs to defendant.

6. The District Court erred in not holding the patent in suit valid and infringed, in not granting the relief prayed for in the complaint, and in not dismissing the counterclaim, with costs to plaintiff.

Dated: December 31, 1956.

/s/ J. CALVIN BROWN,

Attorney for Plaintiff-Appellant.

BROWN, JACKSON, BOETTCHER  
& DIENNER,

/s/ ARTHUR H. BOETTCHER,

Counsel for Plaintiff-Appellant.

Acknowledgment of Service attached. [301]

[Endorsed]: Filed Jan. 2, 1957.

[Title of District Court and Cause.]

DESIGNATION OF CONTENTS OF  
RECORD ON APPEAL

Pursuant to Rule 75(a) of the Federal Rules of Civil Procedure, the plaintiff-appellant hereby designates for inclusion in the record on appeal the following:

1. Complaint.
2. Answer and Counterclaim.
3. Reply to Counterclaim.
4. Notice Pursuant to Title 35 U.S.C. 282.
5. Interrogatories by Plaintiff (Pl. Ex. 14).
6. Plaintiff's Requests for Admissions of Fact (Pl. Ex. 7).
7. Answer to Interrogatories by Plaintiff (Pl. Ex. 15).
8. Defendant's Submission of Document Pursuant to Proffer Made During Trial.
9. Transcript of Proceedings and Evidence at Trial. (Omitting Opening Statements, Page 2, line 8, — Page 23, line 8.) [302]
10. All of Plaintiff's Exhibits, said Exhibits being as follows: Plaintiff's Exhibits 1 to 23-A, inclusive, including 15-A, 22-A, 22-B and 23-A.
11. All of Defendant's Exhibits, said Exhibits being as follows: Defendant's Exhibits A to I, inclusive.
12. Order for Transmittal of Original Exhibits.
13. Notice of Decision.
14. Findings of Fact.
15. Conclusions of Law.

16. Judgment.
17. Notice of Appeal.
18. Appeal Bond.
19. Statement of Points.
20. This Designation of Contents of Record on Appeal.
21. Clerk's Certificate.

Dated: December 31, 1956.

/s/ J. CALVIN BROWN,  
Attorney for Plaintiff-Appellant.  
BROWN, JACKSON, BOETTCHER  
& DIENNER,

/s/ ARTHUR H. BOETTCHER,  
Counsel for Plaintiff-Appellant.

Acknowledgment of Service attached. [303]

[Endorsed]: Filed Jan. 2, 1957.

---

[Title of District Court and Cause.]

### ORDER FOR TRANSMITTAL OF ORIGINAL EXHIBITS

Upon consent of the parties and it appearing to the Court that the original exhibits in this action should be inspected by the United States Court of Appeals for the Ninth Circuit:

It Is Ordered that the Clerk of this Court shall transmit to the United States Court of Appeals for the Ninth Circuit all of Plaintiff's Exhibits, namely Plaintiff's Exhibits 1 to 23-A, inclusive, including 15-A, 22-A, 22-B and 23-A and all of De-

fendant's Exhibits, namely Defendant's Exhibits A to I, inclusive, to be safely kept by the clerk of said Court of Appeals [304] for the use of that Court in the consideration of this action, and thereafter to be returned by him to this Court.

Dated: January 2, 1957.

/s/ ERNEST A. TOLIN,  
Judge of United States District  
Court.

The above order is consented to,

/s/ J. CALVIN BROWN,  
Attorney for Plaintiff-Appellant.

/s/ DONALD C. RUSSELL,  
Attorney for Defendant-  
Appellee. [305]

[Endorsed]: Filed Jan. 3, 1957.

---

[Title of District Court and Cause.]

### CERTIFICATE OF CLERK

I, John A. Childress, Clerk of the United States District Court for the Southern District of California, do hereby certify that the foregoing pages, numbered 1 to 306, inclusive, contain the original—

Answer and Counterclaim; Answer to Plaintiff's Interrogatories; Bond on Appeal; Designation of Record on Appeal; Notice of Appeal; Order Extending Time to Docket Appeal; Order for Transmittal of Original Exhibits; Statement of Points on Appeal; Further Authorities Submitted by Plaintiff; Closing Brief for Defendant; Brief for Plain-

tiff; Reply Brief for Plaintiff; Complaint; Stipulation for Costs; Notice of Decision; Defendant's Reply to Plaintiff's Opposition to Motion for Summary Judgment; Findings of Fact and Conclusions of Law, Proposed; Findings of Fact and Conclusions of Law and Judgment; Interrogatories by Plaintiff; Defendant's Memorandum Prior to Trial; Motion and Notice of for Summary Judgment; Names and Addresses of Attorneys; Notice by Defendants, Pursuant to Title 35, Sec. 282; Opposition to Defendant's Motion for Summary Judgment; Order; Plaintiff's Comments on Defendant's Reply to Plaintiff's Opposition to Motion for Summary Judgment; Reply to Counterclaim; Request of Plaintiff for Admissions of Fact; Stipulation and Order Continuing Hearing on Motion for Summary Judgment; Stipulation and Order Correcting Reporter's Transcript; Submission of Documents by Defendants Pursuant to Proffer Made During Trial; Proposed Summary Judgment; Plaintiff's Trial Memorandum; and a full, true and correct copy of the Minutes of the Court on June 21, 1954; July 19, 1954; Sept. 29, 1954; May 2, 1955; October 21, 1955; Feb. 3, 1956; May 1, 1956; May 3, 1956; May 4, 1956; Oct. 12, 1956; and Nov. 5, 1956; which, together with the original of Plaintiff's Exhibits 1 through 23-A, inclusive, including 15-A, 22-A, 22-B, and Defendant's Exhibits A through G, inclusive and two volumes of Reporter's Transcript of Proceedings had on May 3, 1956 and May 4, 1956, in the above entitled cause, constitute the transcript of record on appeal to the United



States Court of Appeals for the Ninth Circuit, in said cause.

I further certify that my fees for preparing the foregoing record amount to \$1.60, which sum has been paid by appellants.

Witness my hand and the seal of said District Court, this 8th day of February, 1957.

[Seal] JOHN A. CHILDRESS,  
Clerk,

/s/ EDWARD F. DREW,  
Chief Deputy.

---

In The United States District Court, Southern  
District of California, Central Division

No. 16,413-T

CONTAINER CORPORATION OF AMERICA,  
Plaintiff,

vs.

M.C.S. CORPORATION, Defendant.

REPORTER'S TRANSCRIPT OF  
PROCEEDINGS

Los Angeles, California  
May 3, 1956

Honorable Ernest T. Tolin, Judge Presiding.

Appearances: For the Plaintiff: Arthur H.  
Boettcher, 53 West Jackson Boulevard, Chicago,

Illinois, and J. Calvin Brown, 704 South Spring Street, Suite 804, Los Angeles, California.

For the Defendant: Harris, Keich, Foster & Harris, by: Donald C. Russell, 417 South Hill Street, Suite 321, Los Angeles, California. [1\*]

Thursday, May 3, 1956. 1:35 P.M.

The Court: Call our case, please.

The Clerk: 16,413 Container Corporation of America v. M.C.S. Corporation.

Mr. Boettcher: Plaintiff is ready.

Mr. Russell: Defendant is ready. [2]

\* \* \* \* \*

The Court: Are you ready to proceed with the evidence?

Mr. Boettcher: I desire, in the first instance, to offer in evidence a number of exhibits requiring no testimony, and I shall do that, if I may.

Mr. Russell: May I interrupt, Mr. Boettcher?

Mr. Boettcher: Surely.

Mr. Russell: So far as exhibits are concerned, we have several prior art patents here and I would be willing to stipulate with you, if you so desire, that soft copies of any patents may be introduced subject to any correction by certified copies, if, in fact, corrections need be made.

Mr. Boettcher: I will be very pleased to stipulate that, if it will facilitate your proofs. However, I have these organized, and I would like to introduce them.

---

\* Page numbers appearing at top of page of original Reporter's Transcript of Record.

Mr. Russell: Very well.

The Court: All right.

Mr. Boettcher: If you can avoid duplication later, that [23] will be fine for the record.

Mr. Russell: Very well.

Mr. Boettcher: I offer in evidence a certificate of the Secretary of State of Delaware, evidencing the corporate capacity of the plaintiff.

The Court: Received.

(The document referred to was marked Plaintiff's Exhibit 1 and was received in evidence.)

Mr. Boettcher: And I offer this as Plaintiff's Exhibit 2, a certificate of the Secretary of State of the State of California, evidencing the corporate capacity of the defendant.

The Court: Received.

(The document referred to was marked Plaintiff's Exhibit 2 and was received in evidence.)

The Court: In the light of your remarks, I am going to receive each one, without waiting a minute or so to hear an objection,—

Mr. Russell: Yes.

The Court: —but if you have objection, let me know.

Mr. Russell: I certainly shall, your Honor.

Mr. Boettcher: As Plaintiff's Exhibit 3, I offer a certified copy of the Poole patent in suit, United States Letters Patent No. 2,638,261.

The Court: Received. [24]

(The document referred to was marked

Plaintiff's Exhibit 3 was received in evidence.)

Mr. Boettcher: As Plaintiff's Exhibit 4, I offer a certified copy of a portion of the Digest of the United States Patent Office, showing the title of the patent in suit to be in the plaintiff.

The Court: Received.

(The document referred to was marked Plaintiff's Exhibit 4 and was received in evidence.)

Mr. Boettcher: As Plaintiff's Exhibit 5, I offer a certified copy of a so-called file wrapper and contents of the patent in suit.

I might say at this point that Mr. Russell pointed out to me before this session that there is one already on file, which we used in connection with the motion for summary judgment.

The Court: Of course, you have to make a full record on the trial of the case,—

Mr. Boettcher: That is right.

The Court: —so the one you now offer is received. If you want to offer anything from the record on the motion for summary judgment and avoid duplication, you may offer it by reference.

Mr. Boettcher: If I may do it this way, by offering this, I think I would rather do it. [25]

The Court: You do it your way.

Mr. Boettcher: As I say, I have it in an orderly fashion.

The Court: You are proceeding very expeditiously.

The Clerk: Plaintiff's 5.

(The document referred to was marked Plaintiff's Exhibit 5 and was received in evidence.)

Mr. Boettcher: I offer as one exhibit, as Plaintiff's Exhibit 6, certified copies of the references which were cited by the Patent office in the file history of the patent in suit. That is in order to make that Patent office proceeding entirely complete.

The Court: Received.

(The documents referred to were marked Plaintiff's Exhibit 6 and were received in evidence.)

Mr. Boettcher: And I will offer in evidence plaintiff's requests for admissions of fact under Rule 36 of the Rules of Civil Procedure. They were filed on or about March 30, 1956, and should be made a part of the record.

The Court: Received.

(The documents referred to were marked Plaintiff's Exhibit 7 and were received in evidence.)

Mr. Boettcher: Mr. Russell, may we have the record show that these requests for admissions were not answered by the defendant, and, therefore, under the rule, are to be taken as [26] admitted?

Mr. Russell: The requests were not answered, your Honor.

The Court: Do you mean by that that they are admitted?

Mr. Russell: In accordance with the rule, they are deemed admitted.

The Court: It wasn't an inadvertence?

Mr. Russell: No, your Honor.

Mr. Boettcher: I might say that I spoke to Mr. Russell about that before the session, so there would be no question about inadvertency.

Now, in our requests for admissions of fact we made reference to certain exhibits, and I shall now proceed to offer those exhibits.

As I pointed out at the beginning, this really facilitates the introduction of evidence a great deal. So as Plaintiff's Exhibit 8 I introduce a specimen of the accused lid, large size.

The Court: Received.

(The lid referred to was marked Plaintiff's Exhibit 8 and was received in evidence.)

Mr. Boettcher: As Plaintiff's Exhibit 9, I introduce a specimen of the accused lid, small size.

The Court: Received.

(The lid referred to was marked Plaintiff's Exhibit 9 and was received in evidence.) [27]

Mr. Boettcher: As Plaintiff's Exhibit 10, I offer "Plaintiff's Exhibit Specimen of Defendant's Literature No. 1."

The Court: Received.

(The document referred to was marked Plaintiff's Exhibit 10 and was received in evidence.)

Mr. Boettcher: As Plaintiff's Exhibit 11, I offer "Plaintiff's Exhibit Specimen of Defendant's Literature No. 2."

The Court: Received.

(The document referred to was marked

Plaintiff's Exhibit 11 and was received in evidence.)

Mr. Boettcher: As Plaintiff's Exhibit 12, I offer "Plaintiff's Exhibit Defendant's Advertisement" appearing in the Locker Management for January, 1953.

The Court: Received.

(The document referred to was marked Plaintiff's Exhibit 12 and was received in evidence.)

Mr. Boettcher: As Plaintiff's Exhibit 13, I offer a copy of plaintiff's letter of notification to defendant, dated November 2, 1953. By "notification" I mean notice of infringement of the patent in suit.

The Court: Received.

(The letter referred to was marked Plaintiff's Exhibit 13 and was received in evidence.)

Mr. Boettcher: Plaintiff also filed interrogatories at the same time as the requests for admissions, that is, on or [28] about March 30, 1956. And in order to make them of record, as part of the evidence, I offer them.

The Court: Received.

The Clerk: Plaintiff's 14.

(The document referred to was marked Plaintiff's Exhibit 14 and was received in evidence.)

The Court: Do you offer the answers?

Mr. Boettcher: I am ready to do that now.

The Court: You are offering the interrogatories first.

Mr. Boettcher: Right.

The Court: All right. They merely are, of course, a set of questions. They are received in order that we will understand the next exhibit.

Mr. Russell: I believe, your Honor, the questions are fully set forth in the answers, as well, in accordance with the rule.

The Court: They should be.

Mr. Boettcher: May I introduce the answers, so as to be sure they are in the record?

The Court: Received.

Mr. Boettcher: As Plaintiff's Exhibit 15.

The Court: Yes.

(The document referred to was marked Plaintiff's Exhibit 15 and was received in evidence.)

Mr. Boettcher: May I ask Mr. William J. Poole to take [29] the witness stand?

The Court: Yes.

### WILLIAM J. POOLE

called as a witness on behalf of the plaintiff, having been first duly sworn, was examined and testified as follows:

The Clerk: Will you please be seated.

The Court: Mr. Poole, please keep your voice up. In this large room it tends to be dissipated before it reaches our ears.

The Witness: Yes, your Honor.

The Clerk: Your name, sir?

The Witness: William J. Poole.

### Direct Examination

Q. (By Mr. Boettcher): You have stated your



(Testimony of William J. Poole.)

name for the record?           A. Yes.

Q. What is your age?           A. 37.

Q. Where do you reside?

A. Evanston, Illinois.

Q. That is just outside of Chicago, is it not?

A. Yes, sir, it is.

Q. You are an employee of the Container Corporation of America, the plaintiff in this case, is that right?           A. Yes, sir. [30]

Q. Where do you headquarter with the company?

A. In Chicago, Illinois, at the 35th Street folding carton plant.

Q. What does "folding carton plant" mean in your lingo of the trade?

A. A folding carton is one which is die-cut and scored, assembled in a flat form and shipped to the user in a flat form, to be subsequently squared up and sealed.

Q. In other words, they are blanks?

A. That is right.

Q. Cut to size and scored, ready for folding, and somebody else does the folding later, to complete the carton, is that right?           A. That is correct.

Q. When did you first come with the Container Corporation?           A. May 1st, 1940.

Q. What did you do there?

A. I started in a production training course.

Q. And where was that done?

A. At the same 35th Street plant.

Q. How long did that production training last?

(Testimony of William J. Poole.)

A. For a period of about two months.

Q. What then?

A. I was transferred to a department known as a [31] package development laboratory.

Q. How long were you there?

A. Until about April 1st of 1942.

Q. In that package development laboratory, what kind of packaging were you there concerned with?

A. We were doing experimental work on frozen food packages.

Q. What happened on April 1st, 1942?

A. I left the employ of the company to go into the Service.

Q. You went into the Marine Corps, is that right?      A. Yes, sir.

Q. How long were you in that Service?

A. Until November 17, 1945.

Q. What then?

A. I returned immediately to the employ of Container Corporation, some eight days later, after discharge.

Q. Upon your return to Chicago?

A. That is right.

Q. When you came back at the end of 1945, latter part of 1945, in what capacity did you do so?

A. I was rehired specifically to take the place of the gentleman who was in charge of sales and development in this frozen food package department, since he had announced his intention to leave the company to take other employment about [32] the first of the year, of 1946.

(Testimony of William J. Poole.)

Q. Did he continue there until the first of the year, and were you there at the same time?

A. Yes, sir.

Q. Do I understand that you said that you succeeded him as head of the frozen food division?

A. That is correct, sir.

Q. And that was the 1st of January, 1946?

A. Yes, sir.

Q. At that time, January 1st, 1946, was plaintiff's frozen food division making and selling cartons for frozen foods?

A. Yes, sir, they were.

Q. Tell us about the kind or kinds of cartons they were selling for frozen foods at that time.

A. There were two basic types, one of which was a carton and cellophane bag combination. The other one was a rigid set up container of square cross section, which employed a round metal plug which was designed for inserting into a round opening in the top of the container for closure.

Q. In using the word "setup" there, you mean a blank had been forwarded to form an actual carton with volume, is that right?

A. That is correct, sir.

Q. Go back to the cellophane bag-and-carton combination [33] arrangement that you spoke of.

A. Basically the cellophane bag formed the protective container for the food to be frozen. The carton, folding carton, which it was placed in, acted primarily as a protection for the bag.

Q. To carry the bag?

(Testimony of William J. Poole.)

A. That is correct.

Q. Well, did the housewife prepare vegetables or fruit and pour it or get it into the bag somehow?

A. That is correct, sir.

Q. And then that was put into the container?

A. That was put into the folding carton, which had a locking device at the bottom and another one at the top.

Q. What kind of a device?

A. A mechanical locking device, a hook lock of some type.

Q. You mean to hold the bottom together?

A. That is right.

Q. And how was the top formed of that kind of carton?

A. Again the top was, top closure was completed with a similar type of lock.

Q. All right. Now, go to the other type you referred to that had a circular opening in the top. As I understand it, that was a prismatic shape?

A. That is correct. It was square in cross section. [34] If my memory serves me correctly, it was three and a quarter by three and a quarter inches. The quart size, I believe, was some five and a half to six inches high.

Q. How was that top formed?

A. The top consisted of four flaps, one coming off of each of the four side panels. Two of the flaps—four flaps had circular die-cut holes in them. The two flaps which were half flaps, which would meet in the center, had half-circle cut-outs in them,

(Testimony of William J. Poole.)

which, when all four were folded together, would register to form the end result, circular opening.

Q. That meant you had a laminated top of three layers, is that right?      A. That is correct.

Q. And it had a hole in the center of it?

A. That is right.

Q. You said it was square. What was the dimension horizontally?

A. About three and a quarter inches square.

Q. And how large was the opening?

A. Two and three-quarter inches in diameter.

Mr. Boettcher: Does your Honor understand that structure? I have here a metal container which might enable your Honor better to understand what the witness is talking about, although I don't care to put that in evidence. There is no objection to it, but I don't want to clutter up the evidence [35] in the record.

The Court: He may use it as an object to illustrate his testimony.

Mr. Boettcher: That is what I mean. Thank you.

The Court: You hold it up and show me whatever is necessary in order to illustrate your testimony.

Q. (By Mr. Boettcher): Does the container with a top, that has just been handed you, fairly illustrate the kind of a container you are talking about, except that this is metal and the other was paperboard?      A. Yes, it does.

(Testimony of William J. Poole.)

Q. Now, in that paperboard container structure, what was that top made of?

A. The top, of course, was of paper, an extension of the side panels of the carton.

Q. How about the closure for the opening in that top?

A. The closure was a stamped metal plug, substantially the same as this (indicating).

Q. About what was its height?

A. It had a recess depth of perhaps a quarter of an inch.

Q. And that fit into the circular opening at the top?      A. That is correct.

Mr. Boettcher: May I relieve the witness of that?

The Court: You just go ahead and present the case [36] according to your style, and I will try to follow it. If I feel confused, I will let you know.

Q. (By Mr. Boettcher): You are familiar with locker plants, are you not?      A. Yes, sir.

Q. When did you first become familiar with them?

A. I would say at the outset, when I first started working in this package development laboratory.

The Court: Are you speaking of frozen food locker plants?

The Witness: Yes, sir.

Q. (By Mr. Boettcher): Will you please explain the modus operandi of a locker plant and how it serves the public?

A. Well, the purpose is twofold. One, to furnish a means of sharp or quick freezing of the food prod-

(Testimony of William J. Poole.)

ucts which the housewife has previously prepared and packaged and brought into the locker plant. The sharp freezing is done in a range of minus 15 degrees Fahrenheit to perhaps as low as minus 30 degrees Fahrenheit. Subsequent to the sharp freezing it is normal procedure to transfer the food packages from the sharp freeze to a zero degree room which is usually compartmented with aisles and tiers of locker boxes, which are rented by the individual for the storage of this food. Usually they are rented on a monthly or annual rental basis.

The Court: Before we get to another question, I have a [37] jury deliberating and I have just received a note.

Mr. Bailiff, please hand the note to the attorneys so they will become familiar with it, and we will take the matter up at the recess time.

Q. (By Mr. Boettcher): I suppose these lockers, or what did you call them, lockers or lock boxes?

A. They are known as individual frozen food lockers.

Q. I suppose that space is a factor there?

A. Yes, it is, definitely.

Q. In other words, the rental is more or less proportionate to the size?      A. Yes, it is.

Q. Are you in a position to enlighten us somewhat on the matter of these cold compartments in ordinary domestic refrigerators?

A. They are not primarily for the freezing or long-period storage of food. They ordinarily run

(Testimony of William J. Poole.)

at a temperature slightly above zero. Their primary function is one of short-period storage.

Q. But they do freeze initially, do they not?

A. Oh, they can freeze, yes, sir.

Q. The idea being mainly that they can freeze fruits or vegetables or any other foods, but not to be kept at great length of time, is that right?

A. That is correct. [38]

Q. Do you know, as a matter of history, when such locker plants as you have described came into being or, at least, to popular knowledge?

A. To the best of my knowledge, around 1937, 1938.

Mr. Boettcher: I think I would like to introduce this sample of metallic container, after all, and I do so offer it as Plaintiff's Exhibit 16.

The Court: You are now referring, as I apprehend it, to the container which the witness used for illustration here a few minutes ago?

Mr. Boettcher: That is correct, your Honor.

The Court: It is received.

Mr. Boettcher: I would like to change the number of that exhibit to 15-A, if I may, please, in order to maintain my sequence.

The Court: All right. So ordered.

(The container referred to was marked Plaintiff's Exhibit 15-A and was received in evidence.)

Q. (By Mr. Boettcher: Have you knowledge of other types of frozen food containers? I am



(Testimony of William J. Poole.)

speaking of the industry, the practical side of it. That is, in 1946.      A. Yes, sir.

Q. Please state what they were.

A. Well, the box-and-cellophane-bag combination, to which we referred before, would be one category. [39]

The cylindrical type of container with a telescope lid, and as an example that type of container is used for bulk packing or hand-packing of ice cream, with which I think you are familiar.

Q. That has a pillbox cover?

A. That is right.

Then there was the round tapered wax cup, which used a snap-in paper disk as a lid. A good example of that would be the Dixie cup used for ice cream, also.

And then the rigid setup container with the round metal plug, which was just described.

Q. And of these various types, it was either Container or competitors of Container, is that right?      A. That is correct.

Q. Now, in order to keep the record clear as to these 1946 cartons of Container, that are like this Exhibit 15-A in form, the containers were shipped from the Container plant set up and ready to go, is that right?      A. That is correct, sir.

Q. As distinguished from these flat blanks.

A. That is right.

Q. Who made those stamped metal plugs that close the opening in the top of those containers?

(Testimony of William J. Poole.)

A. Those were manufactured by the Crown Cork Speciality Corporation at Decatur, Illinois. [40]

Q. They were sent on up to Container and Container put them into the cartons and sold the combinations that way, is that right?

A. That is correct.

Q. What came after the 1946 type? What happened after that?

A. Well, we decided, for reasons of requests from our consumers that came through our distributors, to attempt to improve the package by fabricating it with a full open top, and a tapered side wall.

Q. By "tapered" you mean that the carton as a whole, that is, the carton body, was flared slightly upwardly?      A. Yes, sir.

Q. What is that flare for?

A. It accomplishes several purposes. One was to facilitate stacking in the locker itself, the bottom of the carton being of a smaller dimension than the recess in the lid.

It also facilitated the saving of storage space, since the cartons could then be nested one inside the other. For that same reason it effected savings in freight.

Q. Why was the full open top carton body desirable?

A. From the standpoint of the user, it was of considerable importance, because it offered an ease of filling the package which had not been present in the carton with the [41] round or restricted open-

(Testimony of William J. Poole.)

ing. Perhaps even more important, it facilitated the emptying of the contents of the package without the need of prior defrosting, which in many cases is not desirable.

The Court: I think at this time we will take the afternoon recess, so far as this case is concerned, and have the jury in in the case in which the jury is deliberating. So you take about a 15 or 20-minute recess.

(A recess was taken from 3:00 p.m. to 3:35 p.m.)

Q. (By Mr. Boettcher): Mr. Poole, when was it, approximately, that you went to this full open top thinking regard to the carton body?

A. This was early in the year 1947.

Q. Just before recess you were explaining the desirability of that full open top. I think that you referred to the matter of filling the carton, to begin with, and emptying the carton of the frozen contents. A. Yes, sir.

Q. Will you go on with that, to explain any special advantages beyond the two you have mentioned, if there are any?

A. I think perhaps this was covered, I don't recall,—

Q. I want to be sure, that is the point.

A. The matter of filling, of course, was important. The matter of being able to empty the contents without having to defrost them or without having to cut or otherwise destroy the container, plus the fact that the full open top gave the—al-

(Testimony of William J. Poole.)

lowed the possibility of nesting the cartons to save [42] freight and to save storage space.

Q. Now, in respect of the thawing of the contents, what is the practice with reference to that? Begin with the point that the frozen package is taken from the locker.

A. In the instance of the carton with the restricted opening, it would be necessary to almost completely defrost or thaw in order to empty the contents. Either that or use some sharp implement to cut the carton open to empty the contents.

In some foods, particularly frozen vegetables, it is desirable to begin the cooking process without thawing at room temperature.

Q. Given that kind of a carton body that you have described, what was your thinking with reference to the top for it, the lid for it?

A. We experimented with various possibilities as to materials which might be used to fabricate such a lid or closure piece. We experimented with paperboard, with drawn or stamped metal, as well as molded materials, such as the plastic that we eventually determined was desirable.

Mr. Boettcher: I have here a carton body that I ask to have marked for identification as Plaintiff's Exhibit 16.

(The carton body referred to was marked Plaintiff's Exhibit 16 for identification.)

Q. (By Mr. Boettcher): Mr. Poole, I submit to you a [43] carton body that is marked for identi-

(Testimony of William J. Poole.)

fication as Plaintiff's Exhibit 16, and ask, if you will please, you to identify or tell us what it is.

Mr. Russell: May I see the body?

Mr. Boettcher: Surely. That is one I showed you a little while before the session opened.

Mr. Russell: Yes. Thank you.

The Witness: This carton was one of the initial experimental packages that was made in early 1947.

The Court: May I see that?

The Witness: Yes, sir.

The Court: Thank you.

Q. (By Mr. Boettcher): That is to your own knowledge? A. Yes, sir.

Mr. Boettcher: I offer the carton marked for identification as Plaintiff's Exhibit 16, as Plaintiff's Exhibit 16.

The Court: Received.

(The carton body heretofore marked Plaintiff's Exhibit 16 was received in evidence.)

Q. (By Mr. Boettcher): Proceed with what happened with reference to the top or lid after you considered these various materials from which to make it.

A. We discarded paper and also stamped or drawn sheet metal because we found it was impossible to obtain a liquid-tight closure, using those materials for the lids. [44]

Having determined that it followed that is would be necessary to use some form of a molded material, we discarded metal, of course, because of the expense.

(Testimony of William J. Poole.)

Q. And what molded material did you determine upon?

A. We determined upon a polystyrene plastic material which is molded under heat and pressure.

Q. What are its qualities that led you to choose that material for the lid?

A. Primarily its stability through the temperature range in which it would be used.

Q. You mean it has a very low coefficient of expansion and contraction, is that right?

A. That is correct.

Q. What about the ability to mold it into any desired form?

A. That, of course, is one of the basic characteristics of the material.

Secondary reasons were, of course, cost which appeared practical, and the fact that it was a transparent material also made it desirable, from the standpoint of being able to see the contents of the package.

Q. What did you do about having such lids made or making them yourself?

A. We contacted the Chicago representative of the Crown Cork Specialty Corporation, with whom we were at that [45] time doing business on the other type of cartons, and we brought to his attention samples of the package which we were developing, together with our ideas and sketches as to how we felt this mold should be made, what form we felt the mold should take to manufacture this lid.

(Testimony of William J. Poole.)

Q. By "package" there, do you mean the carton or what? You said you submitted it to him or you conveyed to him something.

A. I can refer to the exhibit just presented here as an example of the type of carton.

Q. You are referring to Plaintiff's Exhibit 16, is that right?           A. Yes, sir.

Q. And this was still early in 1947, is that right?

A. That is right.

Q. Did you do this personally?

A. Yes, I did, sir.

Q. What was the name of the man to whom you spoke in Chicago, the representative of the Crown Cork?           A. Mr. Ves Hoffman.

Q. What was the immediate upshot of that contact with him?

A. He and I made a trip to Decatur, which is the location of their manufacturing operation, to lay this problem out before their engineering and production people. [46]

Q. What happened?

A. We again presented these samples and sketches to the people who would have to build the molds and live with the production problems involved.

Q. By that you mean the carton samples?

A. The cartons.

Q. Where did the situation go from there?

A. We left with an understanding that they would investigate the production problems involved

(Testimony of William J. Poole.)

and report back to my company as to the feasibility of this lid.

Q. Did you order any lids such as had been discussed and determined upon?      A. Yes, we did.

Q. How many?

A. We ordered a quantity of 3,000.

Q. By what date was that done, the actual ordering of 3,000 lids, approximately?

A. We received initial samples, I believe, in June of 1947, and I believe placed the order in July of 1947.

Q. What were these 3,000 to be for?

A. They were to go along with some three thousand trial-run cartons, such as this—

Q. Exhibit 16?

A. Exhibit 16. They were not sold. They were distributed to various locker plants with whom we had previously [47] had contact and from whom we felt we could get cooperation in the form of a field test, with a request that they report back to us the consumer reaction.

Q. When was it that you distributed these 3,000.

A. To the best of my knowledge that occurred around in August. We started distributing these in August of 1947.

Q. When you received these 3,000 for that kind of distribution, did you try out these lids at the 35th Street plant where you were doing your business?

A. Yes, we did. Naturally, receiving a new item,



(Testimony of William J. Poole.)

we wanted to inspect it very carefully and check it up.

Q. What was the result of that?

A. Well, we immediately determined a flaw in our construction, because at that point there had been no allowance made for the double thickness of board at the manufacturer's joint of the carton.

Q. Now, by "manufacturer's joint" you mean what?

A. Well, that is the glued bond between, the glue flap on one panel of the carton, which is glued down to the corresponding meeting panel at the other end of the blank.

Q. By "manufacturer's joint" you mean that it is a joint that is necessarily there in the process of manufacturing, is that right?

A. That is correct.

Q. How did you discover that flaw to which you refer? [48]

A. By using the lid in the manner that the ultimate consumer would use it, by placing it on the carton body and pressing it down.

Q. What happened?

A. We found that we were unable to get a liquid-tight closure at the corner where the manufacturer's or lap joint is.

We also found that in some cases when enough pressure was exerted we would split or crack the material from which the lid was made at that point.

Q. That is the plastic?

A. The plastic.

(Testimony of William J. Poole.)

Q. What did you do about that?

A. We immediately contacted again Mr. Ves Hoffman, the Chicago representative of the Crown Cork Specialty Corporation, to acquaint him with the problem, and also to acquaint him with our thinking as to how this problem should be solved.

We asked him to transmit that information to his engineering and production people.

Q. How did you solve that particular item?

A. By incorporating a recess in the groove which was approximately the thickness of the additional piece of paperboard involved in the glue flap.

Q. That is, you augmented the recess width at that point, is that right? [49]

A. At that point and through that distance.

Q. When you decided on that, what did you do?

A. As I say, we transmitted this information to Mr. Hoffman. We had one visit together on it, at which time we requested him to submit this problem again to his engineering and production people, to see if such an accommodation could be built into the mold from which these lids are formed.

Q. Up to that time had they made a production mold of any kind?

A. No, sir, they had not. They had made a run-up, sample run mold.

Q. By that you mean a single cavity mold?

A. A single cavity, that is correct.

Q. And what did Mr. Hoffman report?

A. He reported back to us in a matters of a few

(Testimony of William J. Poole.)

days that it was entirely feasible to incorporate this feature and that upon our instruction it would be done.

Q. And what followed that?

A. Following that we placed an order with the Crown Cork Specialty Corporation for a production mold.

Q. And that mold would differ from the single cavity experimental mold, is that right?

A. Yes, sir.

Q. In what respect?

A. It would differ in the respect—well, [50] in several respects. One, it would incorporate the additional recess.

Also at that point it took the form of a gang mold, which involved several cavities.

Q. That is for production purposes?

A. For production purposes.

Q. Can you say approximately when you placed the order for the production mold?

A. To the best of my knowledge, that took place in September of 1947.

Q. Did you order lids to be made from that production mold?      A. Yes, we did.

Q. When did you do that, as nearly as you can say?

A. As nearly as I can say, that would fall in late October or November of 1947.

Q. How many did you order at that time of these lids, to be made from the production mold?

(Testimony of William J. Poole.)

A. 100,000.

Q. What about the complementary cartons themselves?

A. We issued production orders to our 35th Street plant to manufacture a corresponding number, 100,000 carton bodies.

Q. Was 100,000 regarded as a large number at that time?

A. No, it was a very small trial quantity.

Q. What was the idea?

A. The idea was to ship approximately 2,000 units to [51] each of 50 selected paper distributors over the country, and to use this as a complete field test, which was designed to either prove or disprove the merit of the package.

Q. When did these cartons and lids become available for delivery?

A. In the early spring of 1948.

Q. And did you start to make sales then?

A. Yes, we did.

Q. I show you a copy of the patent in suit, which is like the certified copy, Plaintiff's Exhibit 3, and ask you if you are the William J. Poole of that patent.       A. Yes, sir, I am.

Q. When did Container give its next order for lids, if you remember?

A. I would say about in August of 1948.

Mr. Boettcher: I have here a plastic lid, which I ask to be marked for identification as Plaintiff's Exhibit 17.

(Testimony of William J. Poole.)

(The lid referred to was marked Plaintiff's Exhibit 17 for identification.)

Q. (By Mr. Boettcher): Mr. Poole, I show you Plaintiff's Exhibit 17, and ask you if you can tell us what it is.

A. This is one of the early production models. It does contain in it the recess to correspond to the manufacturer's joint of the carton body.

Mr. Boettcher: I offer this plastic lid, [52] marked for identification Plaintiff's Exhibit 17, as Plaintiff's Exhibit 17.

The Court: Received.

(The lid heretofore marked Plaintiff's Exhibit 17 was received in evidence.)

Q. (By Mr. Boettcher): Is there anything on this Exhibit 17 to indicate where that enlargement of the peripheral groove or recess is?

A. Yes, there is.

Q. What is it?

A. It takes the form of an arrow which points to the corner at which the recess is.

Q. Now, showing you again the copy of the patent in suit, is that illustrated in the patent?

A. That is the same arrow which shows in Figure 1 on the patent.

Mr. Boettcher: I have another plastic lid I would like to have marked for identification as Plaintiff's Exhibit 18.

(The lid referred to was marked Plaintiff's Exhibit 18 for identification.)

(Testimony of William J. Poole.)

Q. (By Mr. Boettcher): Mr. Poole, I show you a plastic lid marked for identification as Plaintiff's Exhibit 18, and ask you if you can identify it.

A. Yes, sir.

Q. What is it? [53]

A. This is a slightly later model than Exhibit 17.

The Court: May I have 17, please?

The Witness: In that it contains the lettering which was added as the next step after the initial run, which is—

Q. (By Mr. Boettcher): Exhibit 17?

A. Exhibit 17.

The Court: In other respects is it the same as 17?

The Witness: Yes, it is, sir.

Mr. Boettcher: I offer the plastic lid, marked for identification as Plaintiff's Exhibit 18, as Plaintiff's Exhibit 18.

The Court: Received.

(The lid heretofore marked Plaintiff's Exhibit 18 was received in evidence.)

Mr. Boettcher: I have here a print that I ask to have marked for identification as Plaintiff's Exhibit 19.

(The print referred to was marked Plaintiff's Exhibit 19 for identification.)

Q. (By Mr. Boettcher): Mr. Poole, I now show you a print, a print of a shop drawing marked for identification Plaintiff's Exhibit 19, and I ask you if you will tell us what that is.

A. This is a print of a proposed change, that is, the next step beyond the style of molding which is

(Testimony of William J. Poole.)

shown in Exhibit 18. It is dated 10-27-49, and involves the use of [54] the enlarged recess at all four corners of the lid. This recess now taking a triangular shape instead of a rectangle.

Mr. Boettcher: I offer in evidence the print, marked for identification Plaintiff's Exhibit 19, as Plaintiff's Exhibit 19.

The Court: Received.

(The print heretofore marked Plaintiff's Exhibit 19 was received in evidence.)

Q. (By Mr. Boettcher): I observe, Mr. Poole, that this print, Plaintiff's Exhibit 19, is dated October 27, 1949. A. Yes, sir.

Q. And, as I understand it, this was a further idea, is that correct? A. Yes, sir.

Q. Now, have you any idea how many lids of the immediately preceding type were marketed in 1948?

A. Yes, I do.

Q. State what it is, to the best of your recollection.

A. In 1948, which was the year in which we conducted the more or less market survey, we sold only 100,000 units.

Q. And can you state approximately how many were sold of that type in 1949?

Mr. Boettcher: Let the record show that the witness has taken a paper from his pocket to refresh his recollection.

The Witness: Our sales figures for 1949 show approximately [55] 13,500,000.

Q. (By Mr. Boettcher): When you say "units"

(Testimony of William J. Poole.)

does that mean X number of cartons and Y number of lids and your thirteen million is the sum of those two, or what is it?

A. No. This indicates 13,500,000 cartons and 13,500,000 lids.

Q. That is 1949?            A. Yes, sir.

Q. Did that particular type that you began selling in 1948 continue in 1949?            A. Yes, it did.

Q. Can you tell us approximately how many cartons and lids were sold of that type in 1950?

A. Approximately 11,000,000.

Q. Then I take it that the type that had the triangular enlargement at each corner, as indicated in this print, Plaintiff's Exhibit 19, did not come into vogue until when?

A. We started selling that construction in 1950. All cartons and lids prior to shipments in 1950 were of the initial construction, which had the arrow recessed at only one corner and the rectangular rather than triangular recess.

Q. What is that figure for 1950?

A. 11,000,000.

Q. What is the figure for 1951?

A. 12,500,000. [56]

Q. What is the figure for 1952?

A. 16,600,000.

Q. What is the figure for 1953?

A. 15,100,000.

Mr. Boettcher: I now have a carton that I would like marked for identification as Plaintiff's Exhibit 20.



(Testimony of William J. Poole.)

(The carton referred to was marked Plaintiff's Exhibit 20 for identification.)

Q. (By Mr. Boettcher): Mr. Poole, I show you a carton marked for identification as Plaintiff's Exhibit 20, and I ask you if you will tell me what it is.

A. This is substantially the same as the carton which we started selling in 1950, with the glue flap cut off at a 45-degree angle to correspond to the triangular recess in the lid, which was developed at that time.

Q. I observe the patent number appears on the bottom of this particular carton, and the date is 1953. That is, the date of the patent is 1953, so that must be a carton that itself was as late as that or later? A. That is correct.

Q. But the cartons that were used in 1950 and '51 and '52 were the same, is that right?

A. Were substantially the same as that package.

Mr. Boettcher: I offer this carton, marked for identification Plaintiff's Exhibit 20, as Plaintiff's Exhibit 20. [57]

The Court: Received.

(The carton heretofore marked Plaintiff's Exhibit 20 was received in evidence.)

Q. (By Mr. Boettcher): Do you know when the Container Corporation began placing the patent number on the carton?

A. I believe that that started with the first of our production for 1954 sales.

Q. And that patent number is applied to the car-

(Testimony of William J. Poole.)

ton by the ordinary process of printing, is that right?      A. Yes, it is.

Q. Up to that time you hadn't put the patent marking itself on the lids?      A. No, sir.

Q. Why?

A. Well, up to that time—may I refresh my memory on the exact date of issue of the patent?

Q. The date of issue is in 1953.

A. Well, at the time of issue of the patent, of course, there was a substantial stock of already fabricated lids. Also, there were several sets of quite expensive molds which had been made to manufacture these lids in large quantities. And until the normal life of these molds was realized we did not wish to destroy them, because of the investment.

Mr. Boettcher: I have here another plastic lid which I ask to have marked for identification Plaintiff's Exhibit 21. [58]

(The lid referred to was marked Plaintiff's Exhibit 21 for identification.)

Q. (By Mr. Boettcher): Mr. Poole, I now show you a plastic lid marked for identification Plaintiff's Exhibit No. 21, and ask you if you will please tell us what that is.

A. This is a lid which was manufactured from the revised molds in which we had incorporated the triangular recess in each corner, as opposed to the single rectangular recess in one corner.

Q. That lid has no arrow on it?

A. This lid has no arrow, no, sir.

(Testimony of William J. Poole.)

Mr. Boettcher: I offer in evidence the plastic lid, marked for identification Plaintiff's Exhibit 21, as Plaintiff's Exhibit 21.

The Court: Received.

(The lid heretofore marked Plaintiff's Exhibit 21 was received in evidence.)

Q. (By Mr. Boettcher): Why is there no arrow on Exhibit 21?

A. Because of the fact that there is a recess in each of the four corners, which is triangular, and the fact that the glue flap at the top of the manufacturer's joint had been cut away at a 45-degree angle, thus eliminating the necessity for registering any particular corner of the lid with any particular corner of the carton body. [59]

Q. By cutting the flap away at a 45-degree angle at the top you were referring to the flap as shown in Exhibit 20, is that right?

A. That is correct.

Q. So that the housewife can have the lid relative to the carton either at zero or at 90 degrees or at 180 degrees or 270, is that correct?

A. That is correct.

Mr. Boettcher: Take the witness. Direct examination is closed.

The Court: Would you rather wait until tomorrow for your cross examination?

Mr. Russell: Yes, your Honor. In fact, what I may do, to simplify the matters, I would prefer to wait until tomorrow to cross examine.

For the benefit of counsel, I would like to intro-

duce what exhibits I have; for purposes of the record, I would like to use them in connection with the witness.

The Court: All right.

Mr. Russell: Heretofore, your Honor, we have already marked as Defendant's Exhibits A through D, inclusive, in connection with the motion for summary judgment, various patents.

I would like to include Defendant's Exhibit C in connection with the motion for summary judgment as Defendant's [60] Exhibit A. One moment, please.

The Court: C on the motion for summary judgment will become in this proceeding—

Mr. Russell: Perhaps I am in error. Perhaps you can advise me. Did you introduce in evidence the patent to Sidebotham, No. 2,139,626?

Mr. Boettcher: You mean on the motion—

Mr. Russell: No, as of today, as being one of the file wrappers in connection with the patent.

Mr. Boettcher: Yes, it is.

Mr. Russell: That will dispense with that. I would like to offer Defendant's Exhibit A marked for identification, the file wrapper and contents of Patent No. 2,392,959, granted January 15, 1946, to Raymond H. Van Saun.

Mr. Boettcher: I object to the exhibit as immaterial to this case.

Mr. Russell: I believe the exhibit is material, your Honor, because we intend to use the file history of the patents to Van Saun.

The Court: What is the foundation for these

exhibits? I think it is material if it is properly authenticated.

Mr. Russell: It is a certified copy, your Honor, of the file wrapper and contents of the United States Patent Office in connection with the Van Saun patent.

The Court: You are contending it is prior art?

Mr. Russell: Yes, your Honor.

Mr. Boettcher: I don't see how——

The Court: We will have to examine it to see if it is.

Mr. Boettcher: The Sidebotham patent may be of the prior art, but the file history of the application which led to the patent is certainly not prior art.

Mr. Russell: I may add, your Honor, the patent to Van Saun was a very pertinent reference, in our opinion, that was not cited by the Patent Office Examiner.

The Court: Counsel's point, as I get it, is that while the patent would be evidence, the file wrapper itself is simply relating the history of the proceedings in the Patent Office.

Mr. Russell: Which is very important on the question of whether Mr. Poole is, in fact, the original inventor of the concept of the patent now in issue.

The Court: I will take that one under advisement and sleep on it overnight.

Mr. Boettcher: Shall I say any more on it for the moment? The point is the date of the Side-

botham patent is adequate so far as what it represents is concerned. Is that not right?

Mr. Russell: Perhaps Mr. Boettcher or I may be mistaken. This is not the Sidebotham file history. This is the Van Saun file history. [62]

Mr. Boettcher: I probably misspoke the word. What is the date of the Van Saun patent?

Mr. Russell: The Van Saun patent was issued January 15, 1946.

The Court: This point as to whether the history is contained in that file wrapper is admissible. What is the literature on it? I have never had that question raised here, but it certainly must have come up in some court. What have they been holding?

Mr. Boettcher: The point, your Honor, is that the Van Saun patent issued on January 15, 1946; the patent in suit was filed on May 10, 1948.

Now, this Van Saun issue date is more than two years prior to the Poole patent in suit, filing date. Therefore, Van Saun is of the prior art,—

Mr. Russell: Certainly is.

Mr. Boettcher: —standing *my* itself. Its pertinency is another story. And it speaks for itself on its face as to that. As to that, apparently, my adversary and I are going to disagree. I don't see that the file history, that which preceded the issue of the Van Saun patent can possibly make any contribution material here.

The Court: What do Walker and the other writers on this subject say about it?

Mr. Boettcher: I never heard it suggested before. [63]

The Court: Have you?

Mr. Russell: Not in Walker, your Honor.

The Court: Anyone else?

Mr. Russell: Well, no.

The Court: Tenth Circuit or some such?

Mr. Russell: No. It is a matter of procedure, I believe, to be well recognized, that anything that would tend to show that the alleged inventor is not, in fact, the original inventor is admissible as evidence. And this is well set forth in the file history of the patent to Van Saun, the application, of course, which was handled by patent counsel for the plaintiff in this case.

It is very important. It goes to knowledge of the plaintiff as to who was the inventor, and also the fact that Mr. Van Saun was the inventor. That is our position, and that is what we intend to prove by use of that file history.

Mr. Boettcher: If it is your contention that Van Saun is a prior inventor, prior to Poole, of the subject matter of the patent in suit, firstly you have to plead it in order to present it in the evidence.

Mr. Russell: The patent to Van Saun was noticed under Title 35.

Mr. Boettcher: But that is as a publication, that is as a patent,—

Mr. Russell: I submit—— [64]

Mr. Boettcher: —and not evidence of prior invention. That is another story.

Mr. Russell: I submit the file history is part and parcel of the patent issued. It is a public record.

The Court: Unless you are able to cite me to

some authority which I can read here in a matter of a few moments, I will have to do individual research and give further consideration to it.

So if that is the state of the case, we might as well recess it until tomorrow.

Mr. Russell: May I mark a few other items for identification, your Honor?

The Court: Oh, yes. I will take the offer of that file wrapper under advisement. What is its number?

The Clerk: Defendant's A.

Mr. Russell: Defendant's A marked for identification.

(The document referred to was marked Defendant's Exhibit A for identification.)

Mr. Russell: Next in order, your Honor, is a prior art book which was lodged with your Honor in chambers, together with a memorandum pursuant to the local Rule 12. This prior art book contains the seven prior art patents that we noticed under Title 35.

I would like to have that marked for identification as Defendant's Exhibit B, and I would like to offer the prior art [65] book in evidence at this time.

The Court: Any objection to it?

Mr. Boettcher: What is the number? I have a copy of it.

Mr. Russell: I submitted a copy to Mr. Boettcher, your Honor, before the trial.

Mr. Boettcher: Yes, I have a copy.

The Court: Received.

Mr. Boettcher: No objection.



(The document referred to was marked Defendant's Exhibit B and was received in evidence.)

Mr. Russell: I also have——

Mr. Boettcher: Just a moment. I haven't looked at it. If it is prior art, that is all right. But let me look over the patents in it.

The Court: Are you referring to B?

Mr. Russell: Yes, Defendant's Exhibit B, your Honor. I may state that the patents as set forth in Defendant's Exhibit B are soft copies of each and every one of the patents noticed, pursuant to Title 35.

Mr. Boettcher: I have no objection, from the standpoint of their not being certified. But I do object to this being called prior art patents, because the Hill patent which issued in 1952, after the application for the patent in suit was filed, is not prior art.

Mr. Russell: To accommodate them, your Honor, may the [66] clerk delete the words "Prior Art" and leave the title as "Patents?"

The Court: Yes, do that, Mr. Clerk.

Mr. Boettcher: I have no objection to that, so long as we don't forget that this one is not a prior art patent.

Mr. Russell: That is a point to be taken care of——

The Court: That is something to be handled in your argument.

Mr. Russell: ——in due course. I have here a piece of paper with a drawing marked "Sketch 1,"

a copy of which was submitted in our memorandum, pursuant to local Rule 12.

I would like to mark this as Defendant's Exhibit C for identification.

Mr. Boettcher: No objection.

The Court: Received.

(The document referred to was marked Defendant's Exhibit C and was received in evidence.)

Mr. Russell: And also Defendant's Exhibit D for identification, which is marked "Sketch No. 2," which is very comparable in nature to Sketch No. 1.

Mr. Boettcher: No objection, assuming it is part of argument.

Mr. Russell: Very well.

The Clerk: Defendant's D.

(The document referred to was marked Defendant's Exhibit D for identification.) [67]

Mr. Russell: I would like to offer them into evidence, if I may.

The Court: Received.

(The document heretofore marked Defendant's Exhibit D was received in evidence.)

Mr. Russell: I have here the cover folder of a publication entitled "Locker Management", issue of June 1951, comprising two sheets, folded one upon the other. I would like to mark that as Defendant's Exhibit E.

(The document referred to was marked Defendant's Exhibit E for identification.)

Mr. Boettcher: No objection.

The Court: It is simply being marked for identification.

Mr. Russell: I would like to offer it, if I may, if counsel has no objection.

The Court: Received into evidence.

(The document heretofore marked Defendant's Exhibit E was received in evidence.)

Mr. Russell: The next defendant's exhibit purports to be an advertisement by Container Corporation of America advertising Vapocan. I would like to mark that as Defendant's Exhibit F.

(The advertisement referred to was marked Defendant's Exhibit F for identification.)

Mr. Boettcher: I don't know anything about that one. [68]

Mr. Russell: I don't either, your Honor.

The Court: Well, it is just being marked for identification now.

Mr. Boettcher: You are not offering it now?

Mr. Russell: Not at this time.

Mr. Boettcher: That has been offered, has it not (indicating)?

Mr. Russell: Yes, it has.

Thank you, your Honor.

The Court: The further trial of this case is recessed until tomorrow morning at 10:00 o'clock. The court until tomorrow at 9:00.

(Whereupon, at 4:40 o'clock p.m., Thursday, May 3, 1956, an adjournment was taken to Friday, May 4, 1956, at 10:00 o'clock a.m.) [69]

Friday, May 4, 1956. 10:40 a.m.

The Court: Since we were unable to convene at 10:00 because of the jury trial, if counsel desire a recess let me know. Otherwise, I will sit through until exactly 12:30 because I know you wish to get back to your bailiwick.

Mr. Boettcher: I would like to, but I will stay as long as necessary.

The Court: If we can finish today, well and good. I would take a short noon recess except I made a luncheon engagement some time ago and I want to keep it. If you want a recess, let me know. Otherwise, we will sit until 12:30.

Mr. Russell: Yesterday you recall, your Honor, we discussed the propriety of admitting the file wrapper of the patent to Van Saun into evidence. I have researched the subject, and I would like to present the matter to the court, if you so desire, at this time.

The Court: Yes.

Mr. Russell: Initially, your Honor, the Answer by the defendant sets forth various affirmative defenses directed to showing invalidity of the patent in suit. And I call your attention particularly to affirmative defense Paragraph V of the Answer, which states that:

“The alleged inventions or discoveries claimed in Letters Patent No. 2,638,261 were not patentable [71] to the alleged inventor named therein, under the provisions of Section 4886 of the Revised Statutes,” and also subject to Title 35, United States Code 1952, Section 102.

Now, Section 102, your Honor, Title 35, provides conditions for patentability, novelty and loss of right to a patent. Section 102 states, and I am quoting now in part:

“A person shall be entitled to a patent unless:

“(a) The invention was known or used by others in this country.”

Now, referring to the Van Saun file wrapper, it is my position here to show, by means of that file wrapper, it was known to Mr. Van Saun or known to others before it was conceived of by Mr. Poole.

Secondly, Section 102 of Title 35 states:

“The invention was described in a patent granted on an application for patent by another filed in the United States Patent Office before the invention thereof by the applicant for patents.”

Now, note this is section (e) from Section 102 of Title 35:

“\* \* \* was described in a patent granted on an application for patent.”

Subsection (f) of Title 35, 102, further provides:

“He did not himself invent the subject matter [72] sought to be patented.”

It is our position that Mr. Poole did not invent the subject matter sought to be patented because Mr. Van Saun did.

And subsection (g):

“Before applicant’s invention thereof, the invention was made in this country by another who had not abandoned, suppressed or concealed it.”

Mr. Van Saun didn’t abandon it. He may have abandoned his claims, but he didn’t abandon the

subject matter. He didn't suppress it. He didn't conceal it because the file wrapper is a public record in the United States Patent Office.

Further, in our affirmative defenses, Paragraph VII, we assert all the claims are invalid because prior to any invention or discovery by——

The Court: Are you asserting a motion to dismiss now?

Mr. Russell: No, your Honor. I am setting up the reasons that—our Answer sets forth reasons why we believe the Poole patent to be invalid. I can shorten this.

The Court: But this is not the time for argument of the case, so I don't think we should argue further unless something has occurred in the case which necessitates or makes appropriate an immediate dismissal without any question.

So let's get on with the evidence. I took under submission yesterday the question of whether Defendant's A should be admitted. [73]

Mr. Russell: Yes, your Honor.

The Court: I have decided that patents are not the invention. Of course, it wasn't me that decided that. That is old law. I have become reapprised of the consciousness of it. The patent is not the invention. The letters patent create a monopoly in the inventor, and the letters patent don't just spring into existence. They are the culmination of a process which begins long before the Patent Office hears of it, and it is prosecuted through the Patent Office, and I believe when the letters patent are received into evidence that, in view of the public interest in these matters, inasmuch as a patent does

create a monopoly, that the file wrapper which is the official government history of that patent is admissible.

Defendant's A is admitted.

(The document heretofore marked Defendant's Exhibit A was received in evidence.)

The Court: I don't want to have the case argued now. I want to get in the evidence, and to do so without undue delay, so that counsel who has a commitment in the East the first of the week can get to it. And then you may either brief it or you may return at a subsequent date for argument.

Mr. Russell: Thank you, your Honor.

Mr. Boettcher: May I be heard on this point for just a moment? [74]

The Court: Well, I would rather take evidence. I am not going to decide the point now.

Mr. Boettcher: The question before us, as I understand it, your Honor, is whether or not this Van Saun file history shall be received in evidence.

The Court: I have received it. Now, if I was in error on that, you make a motion to strike and I will consider that during this period the case is under submission.

Mr. Boettcher: I understand it isn't necessary to take exceptions.

The Court: I understand it is not, either. But I recognize your action here as an exception and the exception is noted.

Mr. Boettcher: And I shall be entitled to argue at the final hearing whether or not this is acceptable?

The Court: You certainly will. And you can brief it, too, if you want to.

Mr. Boettcher: Yes, your Honor.

Mr. Russell: I believe, your Honor, that Mr. Poole is now available for cross examination.

The Court: Yes. Unless counsel who called him had found something he overlooked?

Had you finished your direct?

Mr. Boettcher: Yes, your Honor.

Mr. Russell: Perhaps, in the interest of saving time, [75] if we may consider my interrogation of Mr. Poole as cross examination, as well as that of an adverse witness, under Rule 43(b)?

The Court: It serves the same purpose, doesn't it?

Mr. Russell: Yes, your Honor.

Mr. Boettcher: In the event that he asks questions not founded on the direct examination, he is making the witness his own, and I trust it will not be necessary for me to make objections or make any remarks to see that it falls in one category or the other.

The Court: Let's see. He says he wants to call him as an adverse witness. I first saw no objection to his doing that, even if he went beyond the scope of your questioning.

However, you are not agreeable to it and that brings to mind the query, is this man an adverse witness within the meaning of the Rule? Is he?

Mr. Russell: I sincerely believe he is, your Honor.

The Court: Why?

Mr. Russell: He is an employee of the plain-



tiff corporation. He is also the inventor, alleged inventor of the patent in suit.

Mr. Boettcher: I accept that statement. I think that he has a right to call him as an adverse witness——

The Court: All right.

Mr. Boettcher: ——and to examine him as such. I simply [76] don't want to make objections as he goes along. I want to facilitate the examination and if a question is beyond the scope of the direct, I want either now or later to be able to so regard it and to have him bound by the answer.

The Court: All right. In the light of that, you had better call him as an adverse witness for your additional matter when you are presenting your own case.

Mr. Russell: Very well, your Honor.

WILLIAM J. POOLE

called as a witness on behalf of the plaintiff, having been previously duly sworn, resumed the stand and testified further as follows:

Cross Examination

Q. (By Mr. Russell): Mr. Poole, you became the head of the frozen food division of the plaintiff corporation January 1946, is that correct?

A. That is correct.

Q. And you have maintained that capacity to this time?           A. No, sir, I have not.

Q. You had an interim where you were not employed by the plaintiff?           A. No, sir.

(Testimony of William J. Poole.)

Q. Would you then explain to me, please, your capacity with the corporation at this time? [77]

A. I am manager of beer package sales, 35th Street plant, folding carton plant in Chicago.

Q. That is not the frozen food division then?

A. No, sir, it is not.

Q. However, you have been employed continuously by the plaintiff since 1946?      A. Yes.

Q. Now, Mr. Poole, although you believe yourself to be the first and original inventor of the patent in suit, which is Plaintiff's Exhibit 3, if you were presented with evidence and facts to show to the contrary, would you admit that you were not the inventor?

Mr. Boettcher: I object to that.

The Court: That is argumentative. Sustained.

Q. (By Mr. Russell): Referring, Mr. Poole, to Plaintiff's Exhibit 16, which I hand to you, on what date—and be as accurate as you can—did that physical embodiment, Plaintiff's Exhibit 16, come into existence?

A. This particular carton, may I ask?

Q. Yes.

A. I wouldn't be able to pin down an exact date, as to when this particular sample carton was manufactured. I can give you a general date. This carton was produced during our experimental work on this type of package early in 1947.

Q. Now, let's not refer to the particular Exhibit [78] No. 16 in front of you. Let's say the first carton of that type, when did it come into existence?

A. To my knowledge?

(Testimony of William J. Poole.)

Q. Yes.

A. That was again early in 1947.

Q. Now, early 1947, could you say March of 1947?

A. I don't think I could pin down an exact date. I can say it was prior to May of 1947.

Mr. Russell: May I mark for identification, your Honor, what appears to be a large milk container, and this was produced by Mr. Boettcher, counsel for the plaintiff. I would like to mark it Plaintiff's Exhibit 22-B for identification.

Mr. Boettcher: This is as arranged between us?

Mr. Russell: That is correct, counsel.

Clerk: 22-B.

(The container referred to was marked Plaintiff's Exhibit 22-B for identification.)

Q. (By Mr. Russell): I hand you, Mr. Poole, Plaintiff's Exhibit 22-B for identification, and ask you if you have been at some time prior to conception of your invention familiar with that construction.

A. No, not this construction.

Q. You had never seen a construction such as that before May of 1948? [79]

A. No, not this complete construction (indicating).

Q. Did you ever see a construction similar to it?

A. Yes.

Q. Will you explain the construction?

A. Well, I can liken it to the bottom of a shoe box, since it is basically a setup container.

(Testimony of William J. Poole.)

The Court: Let's see what you mean by "shoe box". Are you referring to the type in which shoes are contained in the retail stores?

The Witness: That is right. It basically has an open top. It is formed of four sides and a solid bottom.

Q. (By Mr. Russell): And the shoe box you refer to likewise has a lap joint joining the sides together?      A. Not necessarily.

Q. Did you know of a particular shoe box that did have a lap joint?

A. I would say that is possible as a construction, yes.

The Court: Lap joints as such are old, aren't they?

The Witness: Oh, yes.

The Court: It isn't claimed that the lap joint is the essence of the invention here?

Mr. Russell: I am not certain of that fact, your Honor.

Mr. Boettcher: I pointed out in my opening statement, if the court please, that the carton in and of itself is old, that is, the carton of the patent in suit; that is, the [80] carton body.

The Court: You are claiming a combination of old elements?

Mr. Boettcher: I am claiming the newness of the cover and the newness of the combination between that new cover and the carton body.

The Court: Then the antiquity of lap joints need not be inquired into.

(Testimony of William J. Poole.)

Mr. Russell: Thank you, your Honor.

Q. (By Mr. Russell): Let us refer, Mr. Poole, to Plaintiff's Exhibit No. 17, which I understand to be the first embodiment of the plastic lid construction of the plaintiff.

How many of those particular plastic lids were made?

A. I can only give you an estimate based on the figures which were brought out in yesterday's questioning. At that time I indicated that we had purchased and sold in 1948 100,000, and in 1949 13,500,000.

Q. Referring now, Mr. Poole, to plaintiff's carton, Plaintiff's Exhibit No. 20, that is a commercial embodiment of the plaintiff at the present time, is it not?

A. That is correct.

Q. Now, note the lap joint, that is, where the tab extends inside and is adhesively secured to the adjacent side wall. Does that lap joint extend to the upper edge of the box?

A. Only at the corner. [81]

Q. Just at the point, isn't that correct?

A. That is correct.

Q. So the entire lap joint does not extend to the upper edge of the container.

A. No, sir, the entire lap joint does not.

Q. Now, referring to your patent, Plaintiff's Exhibit 3,—

Mr. Boettcher: You can use my copy if you like.

Mr. Russell: Very well. Counsel has provided me with a soft copy of the patent in suit, which I

(Testimony of William J. Poole.)

will hand to Mr. Poole in lieu of the certified copy of the original.

Q. (By Mr. Russell): Referring to your patent, Mr. Poole, does the lap joint as shown in its entirety extend to the upper edge of the container?

A. Actually, studying the drawing, it depends upon where the cross section is taken.

Q. I draw your attention to the fact the cross section of Fig. 4 is taken along the line 4—4 of Figure 1.

Would you not say, Mr. Poole, that the construction as shown in your patent, carton construction, is substantially identical to the structure of Plaintiff's Exhibit 16?

A. Definitely it is. I was only trying to ascertain from the drawing itself a correct answer to your question.

Q. Thank you. I now hand you Defendant's Exhibit C, which is identified as "Sketch 1", and ask you if the [82] construction of the carton illustrated in Fig. A is a fair representation of your carton construction.

Mr. Boettcher: I object to that.

The Court: Overruled. The witness will look it over.

You look it over and I will read what my secretary has handed me. You don't have to answer it right off.

Mr. Boettcher: May I be heard?

The Court: Yes.

Mr. Boettcher: I made a point yesterday after-

(Testimony of William J. Poole.)

noon, when this particular drawing was submitted, now submitted to the witness, when it was offered, that I understood this was to be only for the purposes of argument.

Now, I am perfectly willing to have Mr. Poole answer that question, but as my adversary's witness.

The Court: Do you want to accept that condition?

Mr. Russell: Yes, your Honor.

The Court: All right. I don't think it is embraced within cross examination, as such.

Mr. Russell: Very well, your Honor.

The Court: Answer the question.

The Witness: May I have the question?

Mr. Russell: Will the reporter please read the question?

(The question was read.)

The Court: If it isn't, you may point out wherein it differs. [83]

The Witness: In general, yes. However, the illustration doesn't go far enough to describe the entire carton. This could be a cut-away end of any glued sleeve. However, the method of gluing or the method of forming the manufacturer's joint, having an essentially square cross section and a glue lap which is adhered to the fourth side, is in general the same.

Q. (By Mr. Russell): Now, referring, Mr. Poole, to the physical embodiments of Plaintiff's Exhibit No. 16, which is a carton, and Plaintiff's

(Testimony of William J. Poole.)

Exhibit No. 20, which is the commercial embodiment, there is a difference between the two constructions, is there not?      A. Yes, there is.

The Court: You are referring to more than the difference in color, aren't you?

The Witness: Oh, definitely.

The Court: What is the difference?

The Witness: There are minor differences of construction, your Honor. The carton, Exhibit 20, has a slightly greater taper, and in Exhibit 20 you will notice that the glue lap has been cut away at approximately a 45-degree angle, where in this carton, Exhibit 16, the glue lap is full to the top of the container.

The Court: Does that make any difference in the function of the containers? [84]

The Witness: It makes a difference in the ability to effect a proper seal with a given construction of cover.

Q. (By Mr. Russell): I hand you, Mr. Poole, Plaintiff's Exhibit No. 21, and do I understand correctly that that is the commercial embodiment of the plastic lid manufactured by Container Corporation of America?      A. That is, today?

Q. Yes.      A. Yes, it is.

Q. Now, the plastic lid, Exhibit 21, has a peripheral and tapering groove or recess, does it not?

A. Yes, it does, around the entire peripheral length.

Q. It has an offset or increased width in all four corners, does it not?      A. That is correct.



(Testimony of William J. Poole.)

Q. Now, you may at this time apply that particular lid, Exhibit No. 21, which is a commercial embodiment, the lid, to the commercial embodiment of the lid, Plaintiff's No. 20, which is before you, and you would have the small point of the lap joint of the carton extending into only one of those offsets, isn't that correct?

A. That is correct.

Q. What extends into the other offsets where there is no lap joint, if anything?

A. Nothing. [85]

Q. So at the other three corners there is nothing at all to fill in the increased width of the groove?

A. That is correct.

Q. Now, without the double thickness wall at the three corners referred to there cannot be any frictional engagement between the lid and the carton wall, is that correct?

A. No, I would say that is not correct.

Q. Will you kindly explain that, Mr. Poole, in view of your earlier statement there was nothing in the offset or the increased groove?

A. Perhaps I should qualify the previous answer, that there was no element of the carton, the paperboard carton, in the groove. However, this lid was so constructed as to come up to a very fine point of contact with the corner, with each—

Q. Then it is a point of contact that effects the seal, isn't that true?

A. Yes, that is right.

Q. It makes no difference then whether your

(Testimony of William J. Poole.)

container has a lap joint or not, it will still seal, isn't that true? A. No, sir, it is not.

Q. Then in the three corners where you have no lap joint and yet the lid has offsets or increased width, why does it seal?

A. Well, perhaps I mistook your question. [86] You said without a lap joint——

Q. Yes.

A. ——it can be sealed. Without a lap joint we do not have a four-sided carton which is joined.

The Court: You might under some of these processes where things are cast?

The Witness: That is possible, yes.

Q. (By Mr. Russell): So actually, then, if you had a carton that did not have a lap joint at all, perfectly equal width around the entire periphery of the carton, the commercial embodiment of the plaintiff's lid, Exhibit 21, would seal such a carton?

A. If it were possible to make such a paperboard carton, yes.

The Court: The carton wouldn't necessarily be paperboard, would it?

The Witness: Folding cartons of this nature are not ordinarily made out of other materials, your Honor. I mean, it would be impractical to make up such a container as this from metal, for instance.

The Court: Do I take it that the necessity of having, or, the advantages of having collapsible cartons is so they may be shipped flat? Is that an important factor here?

The Witness: It is an important factor in the

(Testimony of William J. Poole.)

general folding carton industry. However, in this case this carton is [87] shipped—it takes the form of what we call a setup or assembled container.

The Court: I have seen cartons—they were not for frozen foods—but I have seen cartons similar to these made apparently of a plastic of some kind, in which there was no lap joint, but it appeared the whole thing had perhaps been sprayed on a mold or poured over a mold of some kind so it came out without any lap joint and without any irregularity or greater density at one point than at another.

The Witness: That is correct. Such containers are available commercially. And where there is no lap joint, of course there is no necessity to provide a recess to accommodate it.

Mr. Russell: Your Honor please, your interrogation has raised a point respecting the particular configuration of shape of the carton commercially manufactured and sold by the plaintiff.

Q. (By Mr. Russell): Now, Mr. Poole, is there anything in the shape of your carton that is covered by your patent?

Mr. Boettcher: I object to that. The witness is not here as a patent expert. I don't know that he has ever read the claims.

The Court: Sustained. I shouldn't ask so many questions. My function is to resolve disputes, rather than create them. [88]

Mr. Russell: Very well, your Honor.

Q. (By Mr. Russell): Did you believe, Mr.

(Testimony of William J. Poole.)

Poole, or do you still believe that the feature of nesting of your cartons is an invention of yours?

A. Oh, no. Cartons have been nested for, I guess, as long as there have been setup packages.

Q. Now, referring to your lid, Mr. Poole,—correction. I would like to refer to your patent.

Mr. Boettcher: Here is a copy.

Q. (By Mr. Russell): The patent in suit.

Now, in the construction shown in your patent you show only one overset or increased width in the lid, isn't that correct?

A. That is correct.

Q: Now, it is true in the construction of your lid, as shown in your patent, that the rest of the groove is of uniform width for the remainder of its length?      A. That is correct.

Q. Now, referring to Plaintiff's Exhibit 21, which is the commercial embodiment of the plaintiff's lid, the groove is widened at more than one point, is it not?      A. Yes, it is.

Q. Now, if the commercial embodiment of Plaintiff's Exhibit No. 21 had only one offset, and then the remainder of the groove would have uniform width, would it not? [89]

A. If there was an offset in only one corner, yes, that is true.

Q. And the fact it has an offset in all four corners, the remainder of the groove is not of uniform width?      A. That is correct.

Mr. Russell: I would like to use these examples produced by the plaintiff, your Honor, and I would

(Testimony of William J. Poole.)

like to have Mr. Poole—it is impossible in this case, as they have holes in them.

May I produce some samples of the plaintiff's commercial embodiment? I would like to demonstrate something.

Mr. Boettcher: Certainly.

The Court: Look them over, counsel, and be sure they are what they purport to be.

Mr. Boettcher: I don't think there is any necessity, but I have done so, anyway.

The Court: We have to guard against inadvertence. We trust our friend, but we must guard against inadvertence.

Mr. Russell: I have here, your Honor, which I have had for some time, three containers and a lid. Here are two more.

Mr. Boettcher: You want to put water in those?

Mr. Russell: Yes. I want Mr. Poole to select any two—I want to put some water in the container and have Mr. Poole demonstrate the function of a housewife in sealing the two parts together.

The Court: The function of the device is the important thing.

Mr. Russell: And it functions properly, yes, your Honor.

The Witness: I would suggest these two (indicating). This one here has a damaged corner (indicating).

Q. (By Mr. Russell): Select any of those two.

A. These two (indicating).

(Testimony of William J. Poole.)

Q. Any one and any lid. There are several to choose from.

I have filled this container not quite halfway. I ask you, Mr. Poole, to kindly apply any of the lids you have before you to the container which contains the water.

The Court: By "lids" you mean lids embodying the structure——

Mr. Russell: Which we are talking about at the present time.

The Court: Yes.

Mr. Russell: I believe the lids before Mr. Poole do contain the offset in each corner, all four.

The Court: We all see that, but the record doesn't.

Mr. Russell: Thank you, your Honor.

The Witness: This lid is equivalent to Exhibit No. 21 (indicating).

Mr. Boettcher: Plaintiff's Exhibit 21.

The Witness: Plaintiff's Exhibit No. 21. [91]

Mr. Russell: May I approach the witness, your Honor?

The Court: Surely.

Q. (By Mr. Russell): Now, Mr. Poole, would you turn the carton on its side?

A. Just lay it on its side?

Q. As a normal housewife would when she places it into the freezer.

A. Well, I will turn it on its side, but that is not normal procedure, to stack this type of package in a freezer or locker in such a manner.

(Testimony of William J. Poole.)

Q. Will you kindly turn it on its side, in any event? A. Yes.

Mr. Russell: Now, the witness has turned the container on its side.

Q. (By Mr. Russell): Now, I have taken a piece of yellow paper, Mr. Poole, and I have slipped it between the container lid and the wall of the container.

How far does the piece of yellow paper extend into that groove?

The Witness: He is using ordinary foolscap.

Q. (By Mr. Russell): It is more than halfway?

A. Yes, it is more than halfway.

Q. Is it three-quarters of the way?

A. I would say it probably is three-quarters of the way. Perhaps even— [92]

Q. Let's do it again. The same is true just about of any position? A. Yes.

Q. Close to the edge, the center and the other edge? A. That is correct.

Mr. Boettcher: I think we ought to have the record show that you are putting this corner of the foolscap between the wall of the carton and the rim, let us say, of the lid, that being the top wall, right?

Mr. Russell: I didn't follow your statement there, Mr. Boettcher.

Mr. Boettcher: You just put the paper between the side wall of the—

Mr. Russell: The outer side wall of the container and into the groove of the lid.

(Testimony of William J. Poole.)

Mr. Boettcher: Yes. But now that side wall that you refer to is horizontal and at the top, is it not? In other words, the carton is lying on its side.

Mr. Russell: Yes.

Mr. Boettcher: And the wall you are now referring to is horizontal, is that not right?

Mr. Russell: Well, the wall is horizontal. The point I am getting at, and I believe Mr. Poole testified the paper went into the groove a substantial distance.

Mr. Boettcher: I am not arguing the point. I [93] simply want the record to show the fact, that is, that the wall you are referring to is a side wall, but it is now in horizontal position.

Mr. Russell: Yes.

Mr. Boettcher: That is all I want to know.

The Court: The container containing the water and with the embodiment of plaintiff's claimed invention, as I understand it, is lying on its side on a table before the witness.

Mr. Russell: That is correct, your Honor.

The Court: And so far as I can see no water is coming out.

Mr. Russell: Very well.

Q. (By Mr. Russell): Now, Mr. Poole, will you turn the container 90 degrees?

A. So it is upside down?

Q. Rotate it by its horizontal axis.

A. (Witness complies.)

Q. That is correct. I will use the same test I did before, taking a piece of yellow paper, and I



(Testimony of William J. Poole.)

slip it into the groove. It goes into the groove between the wall of the carton and the lid more than halfway, does it not?      A. Yes, it does.

Q. That is, at the center of the carton?

A. That is right.

Q. Over to the side of the carton? [94]

A. That is right.

Q. It goes in more than three-quarters of the way.

A. I would say about, perhaps a little more.

The Court: That is near the side, not at the exact——

Mr. Russell: Not at the exact side, no. Approximately halfway in from the corner of the carton.

The Court: Yes.

Mr. Russell: And the same thing on the opposite side.

Q. (By Mr. Russell): We are now approximately three-eighths of an inch from the corner of the carton?      A. Yes.

Q. And does it not extend more than halfway into the groove?      A. Yes, it does.

The Court: The court's observation—now, I am at a different angle than you are——

Mr. Russell: Yes.

The Court: ——*is* it appeared to me it went almost all the way.

Mr. Russell: Very well, your Honor.

The Court: If that isn't so, you might have him turn it the other way, so I can see better.

Mr. Russell: Well, I would like the witness then

(Testimony of William J. Poole.)

to rotate the carton 90 degrees more in the same direction.

The Witness: Almost lost our water. [95]

Mr. Russell: I will use the same test, your Honor.

Will the witness kindly turn the carton 90 degrees on its vertical axis, so the court may view the test I am about to make?

The Court: I don't know what you might be going into in the future, and since I made an observation and the water came out, I should make the observation at this juncture that some water has escaped, but not all of it.

Q. (By Mr. Russell): Using the yellow paper again, Mr. Poole, I will put it along the side of the container and into the groove. How far does it go in?

A. Oh, I would say approximately three-quarters of the way.

Q. And on one side, approximately one-half inch from the side of the carton, how far does it go in?

A. About the same, perhaps even a little more.

Q. On the other side, approximately one-half inch from the edge of the container?

A. Perhaps a little less, but roughly three-quarters of the way.

The Court: At some point you might have that paper you are using made a part of the record.

Mr. Russell: Yes, your Honor. In fact, I will do it at this time. I would like to mark it for identification as Defendant's exhibit. [96]

(Testimony of William J. Poole.)

The Clerk: G.

(The paper referred to was marked Defendant's Exhibit G for identification.)

The Court: That is the paper used in the demonstration.

Mr. Russell: That is correct, your Honor. If I may, your Honor, I would just as leave offer it in evidence.

The Court: Received.

(The paper heretofore marked Defendant's Exhibit G was received in evidence.)

Q. (By Mr. Russell): Now, in view of the demonstration, Mr. Poole, the wall of the carton, that is, Plaintiff's Exhibit No. 20, does not contact the side of the groove of the container lid for more than the depth of the groove, isn't that correct?

Mr. Russell: I perhaps had better rephrase that question, to put it positively, your Honor, if I may.

The Court: Yes.

Q. (By Mr. Russell): The container wall does not contact the side of the groove for a distance greater than the depth of the groove?

A. Which side of the groove, the inner surface of the outer flange, or is it the—

Q. The inner surface of the outer flange, yes.

A. The question is, it does not contact the carton, does not contact that inner surface of the outer flange of the [97] cover for a depth greater than the groove itself?

Q. Yes. A. That is correct.

Q. And the contact is less than the—let's say

(Testimony of William J. Poole.)

less than one-half of the depth of the groove, isn't that correct?

A. We have only proved that it is less than one-half of the depth of the outer flange, by your demonstration.

Q. Very well. To complete, Mr. Poole, would you again rotate the carton in the same direction, 90 degrees, still on its side? I note that the carton is leaking considerably at this time, is that correct?

A. It has lost water, yes, sir.

Mr. Boettcher: In order that this may be visualized by reading the record, let us say that the carton is lying on its side and that it is about a third full of water.

The Court: And the water which has leaked out has, in each instance, so far as I could observe, leaked out at the time it was being rotated, while in motion.

Mr. Russell: In order that your Honor's observation may be further confirmed, may I suggest that Mr. Poole lift the carton and place it in a position on the table where there is no water?

The Court: Mr. Bailiff, let's wipe such water as we have.

Mr. Russell: I note for the purposes of the record that Mr. Poole has again reaffirmed or compressed the lid onto the carton. [98]

Q. (By Mr. Russell): Now, would you kindly place it on the side? A. (Witness complies.)

Q. Again, Mr. Poole, using Defendant's Exhibit

(Testimony of William J. Poole.)

G, I have slipped the paper into the groove adjacent the side wall of the container.

Now, Mr. Poole, how far in does the paper go into the groove?

A. Well, from this demonstration it is impossible to tell, because you can't see the actual depth of the groove. You can only see the depth of the length of the outer flange, the groove being comprised of a shallower depth, as you can see.

Q. I am taking another corner of Defendant's Exhibit G. One corner has become rather damp. I will apply it once more between the wall and the groove.

You still say you cannot tell how far it goes into the groove?

A. I can only tell how far it penetrates under the flange, but that flange is deeper than the actual two-sided groove itself.

Q. The fact is you cannot ascertain because you can't see the groove?      A. That is right. [99]

Q. But you can see the groove in the embodiment in your hand, is that correct?

A. That is correct.

Q. Now, Mr. Poole, let us refer again to Plaintiff's Exhibit No. 21, which is the commercial embodiment of the plaintiff's lid. This is the embodiment with the offset in all four corners, is that correct?      A. That is correct.

Q. Is that construction your original conception?      A. Yes.

(Testimony of William J. Poole.)

Q. Did you conceive of the four-corner offset construction?      A. Yes.

Q. Did you ever file an application for patent covering a four-corner offset construction?

A. I don't believe so.

Q. Do you know whether anybody connected with the plaintiff has filed an application on that four-cornered offset construction?

A. No, I do not.

Mr. Russell: I would like to refer, your Honor, now to the art book entitled "Patents", Defendant's Exhibit B. Copy is in the hands of Mr. Boettcher, counsel for the plaintiff. And I hand Defendant's Exhibit B to Mr. Poole.

Mr. Boettcher: I might give warning, I am going to [100] object to this, but he hasn't opened it yet, so——

The Court: So you don't know what question he is going to ask.

Mr. Boettcher: I don't know what question he is going to ask.

The Court: Let's see. It might not be objectionable.

Q. (By Mr. Russell): Referring to tab 1, Mr. Poole, inside of Defendant's Exhibit B, turning to tab 1——

Mr. Boettcher: I object. That wasn't referred to on direct examination. He is not here as a patent expert. I don't know that he knows anything about that.

The Court: There is no question pending. I

(Testimony of William J. Poole.)

appreciate your being diligent, but I think you jumped the gun.

Mr. Boettcher: I am sorry.

Mr. Russell: Perhaps Mr. Boettcher is anticipating.

Q. (By Mr. Russell): Have you seen the patent to Drake before, identified in tab 1, the Drake Patent No. 1,325,930?

Mr. Boettcher: I say that is outside the scope of the direct.

The Court: Sustained. I will treat it as an objection, although the word "object" isn't in it.

Mr. Russell: In view of the objection, your Honor, I will have to go on to other subject matter, reserving the right to recall Mr. Poole in presentation of the defendant's case. [101]

The Court: All right. Of course, you can't make him an adverse witness, treat him as an adverse witness and an expert at the same time, as your expert.

If he comes on as an expert he would come on as your witness,—

Mr. Russell: I understand that.

The Court: —because he hasn't taken on the character of an expert in the testimony he has thus far given.

Q. (By Mr. Russell): Mr. Poole, you have testified concerning the number of commercial embodiments sold by the plaintiff in connection with various samples before you.

Mr. Poole, how much money has Container Cor-

(Testimony of William J. Poole.)

poration of America spent in advertising the so-called Vapocan?

A. I would have no idea, since I have nothing to do with the advertising department or their budgets or their appropriations.

Q. You wouldn't say they did not advertise considerably, would you?

A. No, sir. Advertising was done. As to the extent of it, however, it would only be a guess and I don't think that is what you are after here.

Q. Have you ever seen any advertisements of the Container Corporation of America respecting Vapocans? A. Oh, yes.

Q. In what publications or periodicals? [102]

A. Well, Locker Management is one. I believe you have an exhibit there (indicating).

Q. You are referring to Defendant's Exhibit E, which I hand you, noting page 2 on the inside?

A. Yes, sir.

Q. Is page 2 a full-page ad of Vapocan, covering the structure which is now in suit?

Mr. Boettcher: It is not for this witness—I object to that question. It is not for this witness to pass upon that which is covered by the patent in suit. So there is no misunderstanding, I thought I had better point that out.

In other words, it isn't for this witness to say what does or does not come under the patent. That is for us—on direct examination I confined myself to the facts as he knows them.

Mr. Russell: He is the inventor, your Honor.



(Testimony of William J. Poole.)

The Court: The objection is sustained. It appears to the court from this Exhibit E that this question and the questions which would follow a natural sequence, if this one be allowed, would call for this witness to interpret Exhibit E, which is an advertising brochure.

Mr. Russell: It is an advertisement brochure, your Honor, of the plaintiff, of which he is an employee.

The Court: Yes, but it has depictions of things other than the particular structure involved here. And I think that [103] it is for counsel to argue the contents of the documentary literature, rather than for the witness to do so.

Mr. Russell: Very well, your Honor.

Q. (By Mr. Russell): Mr. Poole, would you kindly lift the joined Plaintiff's Exhibits 20 and 21, which has been resting on its side for approximately ten minutes? Would you kindly lift it?

A. (Witness complies.)

Mr. Russell: I note considerable water dripping on the side. We shall now wipe it up with a rag.

The Court: It appears to be about two or three centimeters, cubic centimeters of water which had escaped during the time interval.

Mr. Russell: Very well.

The Court: If anyone disagrees with my estimates — they are only rough estimates — you may state it.

Mr. Russell: Well, perhaps we can look at the inside of the container, which I indicated, your

(Testimony of William J. Poole.)

Honor, was filled approximately halfway. It is slightly below the halfway mark at this time. I would say approximately three-eighths full, counsel?

Mr. Boettcher: I don't think I want to make an estimate. The point is that it was about a third full when it was lying on its side, and as you put it on its side now it is about the same. I don't think it is fair to you or to myself to ask me [104] to make an estimate.

Mr. Russell: Very well. I apologize.

Q. (By Mr. Russell): Do you know, Mr. Poole, whether or not the plaintiff Container Corporation of America makes display racks for the invention, subject matter here in suit?

A. We have built some display material, yes.

The Court: What do you mean by "display material"?

The Witness: Retail display stands for displaying the cartons for sale.

The Court: For sale to retail customers?

The Witness: In the locker plants, yes, sir.

Mr. Russell: If I may refer, your Honor, Mr. Poole to Defendant's Exhibit F for identification.

Mr. Boettcher: I am going to object to your even showing that to the witness. It has absolutely no authentication here.

Mr. Russell: Perhaps the witness can authenticate it.

Q. (By Mr. Russell): I will ask you——

Mr. Boettcher: For that purpose, I will withdraw my objection.

(Testimony of William J. Poole.)

Q. (By Mr. Russell): Have you ever seen a piece of paper such as that before (indicating)?

A. No, sir, frankly, I have not. None of the advertising that is done by my company is done in this crude a form.

Q. Have you ever seen a display rack of the type [105] exemplified on the right-hand side of that piece of paper, Defendant's Exhibit F for identification?

A. Yes, a display rack of that general nature. I couldn't actually identify this particular one, however.

Q. That is, would you say that could be or is a display rack manufactured by your company?

A. It could be, but I would have no way of identifying it positively.

Q. Do you know what the policy is with your company with respect to the sale, if any, of such display racks?

A. No, sir, I don't.

Q. You wouldn't know if they give them away, would you?

A. No, sir, I do not.

Q. They may give them away, isn't that true?

A. It is possible, but I am unable to answer in an affirmative or negative manner your direct question.

Q. I draw your attention to the statement on Defendant's Exhibit F, which states, "New Floor Merchandiser Free to the Retail Dealer". Does that refresh your recollection?

A. No, it does not. As I pointed out before, I

(Testimony of William J. Poole.)

cannot identify this as a Container Corporation of America advertisement.

Q. You recognize——

A. I would identify it as not being a product of our advertising department or of our advertising agency. [106]

Q. You would recognize, however, the display rack as depicted on Defendant's Exhibit F as a product of your company?

Mr. Boettcher: I think I will have to object——

The Witness: I would say a possible product.

Mr. Boettcher: ——to this line of examination. This is an utterly unauthenticated piece of paper being submitted to the witness, and he is carrying on an extensive examination of it with him.

The Court: I take it he is attacking commercial success.

Mr. Russell: Yes.

The Court: It is not contended that this is a Container Corporation of America publication, but he is asking him regarding the type of display rack there and the extent to which it is used. This is merely an orienting piece of literature. Objection overruled.

Q. (By Mr. Russell): Will you answer the question?

The Reporter: He answered the question. Just a minute, I will read the record.

(The record was read.)

Q. (By Mr. Russell): Would you have any

(Testimony of William J. Poole.)

idea, Mr. Poole, how much the plaintiff spends each year in manufacturing these display racks?

A. No, sir.

Q. Did you ever work in the plant where the [107] display racks were manufactured?

A. No, sir. Those are fabricated from corrugated box board which is manufactured at a different plant from which I make my headquarters.

Q. Have you ever seen any display racks made by your company?           A. Yes, sir.

Q. Where?

A. Samples of them at the 35th Street plant, where I do make my headquarters.

Q. Any quantity of them?           A. No, sir.

Q. You have no idea how many might have been made?

A. I have no idea. They may have been used extensively or not; I do not know.

Q. Have you ever seen them in retail stores?

A. No, sir, I have not.

The Court: Of course, the extent of offering is not a measure of the extent of acceptance, and the big factor in commercial success is that the object has achieved immediate acceptance by the consumer or user of it.

Mr. Russell: As a result, your Honor, of the invention, not as a result—

The Court: That is right.

Mr. Russell: —of judicious advertising. [108]

The Court: Yes, but whether or not—I had better not say any more.

(Testimony of William J. Poole.)

Q. (By Mr. Russell): Mr. Poole, what is the approximate ratio of sales of cartons to lids of your company?

A. To the best of my knowledge, it would be in a ratio of approximately 10 to 9.

Q. You sell more cartons than you do lids?

A. That is correct.

Q. Do you have any idea, Mr. Poole, what the profit is to the plaintiff on the sale of its cartons?

A. I would say, in answer to that, that the profits of Container Corporation of America on any given item, information about that is the property of my company and I am not in a position of policy which would permit me to divulge that information.

Mr. Russell: I believe it is of importance, your Honor.

The Court: I don't think that profit is important. An item might be commercially successful and a great number of them are vended, but still the profit would be quite small.

Mr. Russell: Perhaps I can rephrase the question then, your Honor, to keep it in terms of comparison rather than monetary figures.

The Court: All right.

Q. (By Mr. Russell): Mr. Poole, respecting the profit made by your company on cartons and the profit made on lids, [109] let's say carton as compared to lid, which item do you make the most profit on?

A. I would say that they were comparable.

(Testimony of William J. Poole.)

Q. You make no more profit on the carton than you do on the lid?

A. To the best of my knowledge, they are in the same general percentage area.

Q. This is based upon your knowledge at the present time of figures which apparently you do have, monetary figures of the profits of your company respecting both items?

A. I do not have monetary figures of my company respecting the profits on both items at this time. I do have figures on total unit sales.

Q. What is the retail price of lids sold by your company?

A. To the best of my knowledge, the combined unit sells at retail for nine and a half to ten cents.

The cost of each separate component being approximately one-half of that total figure.

Q. You sell lids separately, however, do you not?

A. Yes, when they are ordered as such.

Q. They are sold in quantities of four each, twenty each?

A. The retail unit packing happens to be either 10 or 20. [110]

Q. For a package of 10, what is the retail price?

A. I am not too sure what it is currently.

Q. What was it in 1953, '52?

A. About 50 cents, 49 cents, in that area.

Q. Has it ever been lower than 49 cents for a package of 10?

A. I don't believe so. However, there will be variations in different markets. Different types of

(Testimony of William J. Poole.)

outlets will require a lesser or greater profit markup. But I would say that figure was a fairly good general average.

Q. So, based upon that figure, Mr. Poole, each lid sells for about 4.9 cents?

A. I think it would be better to say approximately 5 cents, because there are, as I say, variations in the different markets; that should be close.

The Court: Container Corporation does not sell at retail, does it?

The Witness: No, sir, we do not.

Q. (By Mr. Russell): I refer now, Mr. Poole, to Plaintiff's Exhibit No. 12 in evidence, which purports to be an advertisement of Ree-Seal respecting plastic lids.

Are you familiar with the type of plastic lid illustrated in that advertisement?

Mr. Boettcher: I object. It is outside the scope of the direct. I didn't examine him about the accused lids. [111]

The Court: Sustained.

Q. (By Mr. Russell): Mr. Poole, do you know of any other concern that manufactures a plastic lid which you believe to be comparable to yours?

Mr. Boettcher: I object to that; outside of the scope of the direct.

The Court: Sustained.

Q. (By Mr. Russell): In the paperboard industry, Mr. Poole, is it unusual to make a run of, say, for example, a million boxes? A. Not at all.

Q. That is ordinary?



(Testimony of William J. Poole.)

A. That is common practice, yes.

Q. What would be an average run? I say "average". Let's say a continuous run, from start to stop.

A. An average run of what?

Q. Well, let's take a Meelie machine or a Sperry machine, where the fiberboard is fed in in stock form on one end and it feeds out on the other end cut and scored. What is an average run in quantity?

A. It is very difficult to answer the question categorically. It is not uncommon to see runs of 50,000 cartons and it is also not too uncommon to see runs of five million cartons. It depends on the item and the size of the cut.

Mr. Russell: I believe I will have to reserve the [112] rest, your Honor, for Mr. Poole, for putting on our case. So cross examination, I will release the witness.

The Court: How long do you think the presentation of your case will require, the defendant's case, exclusive of argument?

Mr. Russell: I believe, your Honor, that approximately half or three-quarters of an hour with Mr. Poole, if there are no ostensible objections. And for Mr. Comstock perhaps an hour, an hour and fifteen minutes.

The Court: Is that your evidentiary case?

Mr. Russell: Yes, your Honor.

The Court: How long will it take you to complete the evidence in your case?

Mr. Boettcher: First of all, let me say that there

is no redirect examination now, which, therefore, concludes Mr. Poole's testimony on prima facie.

(Witness excused.)

Mr. Boettcher: I have a few exhibits I would like to introduce, and that will take a few moments and then I expect to rest.

The Court: Then I would take it it is not necessary for me to work into the lunch hour in order to complete this case by a reasonable time this afternoon.

Mr. Russell: I sincerely believe, your Honor, it can be done. [113]

Mr. Boettcher: I take it that we shall not try this afternoon to go beyond the introduction of evidence.

The Court: That is my understanding. Usually in cases of this character I have found it to be the preference of counsel to write a brief or a memorandum of some kind, at least, to cite to the court the literature which the court should read. That has been done to some extent in this case by virtue of a motion for summary judgment.

But, in any event, if counsel would like to take a little time to analyze the evidence and return for argument, or treat it by factual briefs, that is all right.

We will take the recess until 2:00 o'clock. We will sit this afternoon until the evidence is finished.

Mr. Russell: Thank you.

Mr. Boettcher: Thank you.

(Whereupon, at 12:00 o'clock noon, a recess

was taken until 2:00 o'clock p.m. of the same day.) [114]

Friday, May 4, 1956. 2:10 P.M.

Mr. Boettcher: May it please the court, I think the record shows that just before the recess I announced that there would be no redirect examination of Mr. Poole.

The Court: Yes.

Mr. Boettcher: Now, I have a few exhibits that I would like to offer.

Firstly, I offer the exhibit that the counsel for the defendant had marked for identification, Plaintiff's Exhibit 22-B, as Plaintiff's Exhibit 22-B.

The Court: Received.

(The container heretofore marked Plaintiff's Exhibit 22-B was received in evidence.)

Mr. Boettcher: Then I have a plastic cover, which is a duplicate of Plaintiff's Exhibit 8, which with the exhibit tag so attached that it can be used with the carton, and I offer that as Plaintiff's Exhibit 22.

The Court: Is that acceptable?

Mr. Russell: Yes. I would like to examine it.

The Court: I don't think there is any foundation.

Mr. Russell: I do not believe so, your Honor.

Mr. Boettcher: The reason for it is simply that the other exhibit, the corresponding exhibit, was used on the motion for summary judgment and it has tags on it in connection [115] with the requests for admissions of fact. It is identical with this, but

it is so cluttered up with tags that it cannot be used with this.

Mr. Russell: Is not this structure already in evidence, however, Mr. Boettcher?

Mr. Boettcher: The structure is in evidence by way of the requests for admissions of fact, having subsequent introduction in evidence. This is a duplicate.

The Court: I take it this is being offered now so the court will have one that is not encumbered with labels and the like, so the court can make full observation.

Mr. Boettcher: That is correct.

The Court: Any objection?

Mr. Russell: No objection, your Honor.

The Court: Received.

The Clerk: 22.

(The cover referred to was marked Plaintiff's Exhibit 22 and was received in evidence.)

Mr. Boettcher: Now, I have here a drawing of that particular defendant's lid, which I should like to introduce as Plaintiff's Exhibit 22-A. Now, that drawing is the original of the print that was used for that purpose on the motion for summary judgment, so counsel is already familiar with it.

Mr. Russell: I am familiar with the subject matter, but [116] I believe, your Honor, the print itself is objectionable for the reason the accused device speaks for itself and needs no representation such as this.

The Court: Overruled and admitted.

The Clerk: 22-A.

(The drawing referred to was marked Plaintiff's Exhibit 22-A and was received in evidence.)

Mr. Boettcher: Now, Plaintiff's Exhibit 9 is the other type of defendant's lid, and that too is encumbered with tags in such a way it cannot be used with this carton, which I am also going to ask to introduce.

I would like to introduce this quart size duplicate of Plaintiff's Exhibit 8 as Plaintiff's Exhibit 23.

Mr. Russell: No objection.

The Court: Received.

(The container referred to was marked Plaintiff's Exhibit 23 and was received in evidence.)

Mr. Boettcher: And then a final exhibit is the quart size milk carton, which I offer as Plaintiff's Exhibit 23-A.

Mr. Russell: No objection.

The Court: Received.

(The carton referred to was marked Plaintiff's Exhibit 23-A and was received in evidence.)

Mr. Boettcher: Plaintiff rests.

Mr. Russell: I would like to recall Mr. Poole to the stand, your Honor. [117]

The Court: As an adverse witness?

Mr. Russell: As an adverse witness, yes, your Honor, under Rule 43(b).

The Court: All right, take the stand. You have been sworn once.

## WILLIAM J. POOLE

recalled as a witness on behalf of the defendant, under the provisions of Rule 43(b) of the Federal Rules of Civil Procedure, having been previously duly sworn, was examined and testified further as follows:

The Court: Now, while you are called by the defendant, being called as an adverse witness, which means in legal theory there is hostility between you and he, and if you don't understand a question you had better make it known, because when you have an adverse witness most lawyers undertake to get the witness to fall into some kind of a trap. I don't know what you have in mind, Mr. Russell.

And it is perfectly legal, you understand, Mr. Witness, but still be on guard. You are being questioned by someone who is on the other side. If you don't understand the question that is put to you, if you will let that be known I am sure Mr. Russell will rephrase it.

Mr. Russell: I would like to re-enter the territory, your Honor, of Defendant's Exhibit B. That is the art book [118] to which we referred before, comprising the group of patents that have been noticed heretofore in this case.

## Direct Examination

Q. (By Mr. Russell): Now, Mr. Poole, referring again to tab 1 of Defendant's Exhibit B,—

The Court: Do I have one of those?

Mr. Russell: I am sorry, your Honor.

Mr. Boettcher, do you have a copy?

(Testimony of William J. Poole.)

Mr. Boettcher: Certainly.

The Court: It seems to me one was provided me yesterday, but I don't find it on the bench.

Mr. Russell: I believe that is the original. Perhaps you would like to have the court copy and Mr. Poole could use Mr. Boettcher's copy. They are identical in all respects.

The Court: Then I can look at it at the bench here,——

Mr. Russell: Very well. Thank you, your Honor.

The Court: ——without having to look over the witness' shoulder.

Mr. Boettcher: I may have to do the same, if I may.

The Court: Yes.

Mr. Boettcher: That is my only copy.

Q. (By Mr. Russell): Are you familiar with the patent to Drake in Defendant's Exhibit B, that is, Patent No. 1,325,930? [119]

A. No, sir, I am not.

Q. You have never seen that patent before?

A. No, sir.

Q. Looking through the group of patents comprising Defendant's Exhibit B, Mr. Poole, I wish you would thumb through them.

Have you seen any of those patents before?

A. To your tab 2, under the name J. D. Kurz, no.

To your tab 3, W. L. Rutkowski, no.

To your tab 4, G. A. Moore, no.

To your tab 5, R. H. Van Saun, I have not seen

(Testimony of William J. Poole.)

this patent before. I have heard it referred to for the first time in court today.

To your tab 6, A. Merkle, no.

To your tab 7, D. W. Hill, I was shown a copy of this patent earlier this week by Mr. Boettcher. I have not read the specifications nor the claims.

Q. You are, of course, Mr. Poole, familiar with your own patent? You have read it several times, have you not?

A. I am familiar with the specifications. I don't qualify myself as a legal expert, able to read the technical language in the claims or understand it fully.

Q. Very well. Then limiting ourselves to the specifications as set forth in your patent, just what did you contribute to this structure that was new?

Mr. Boettcher: I object to that. In order to answer that intelligently one really has to know what the prior art is and to be able to measure the differences between what the patent shows and what the prior art is.

Mr. Russell: If I may add, your Honor, let's say new to this witness, not—

The Court: As amended, it is a different question. But he is asked a different question. He says new to this witness. The prior question referred to a specific art which was mentioned, and he then now has limited it to new to this witness' understanding.

The Witness: To my knowledge the feature of this development which was new and useful was



(Testimony of William J. Poole.)

the incorporation of a rigid setup, full open top, paperboard container, in combination with a molded cover, specifically designed for the domestic packaging of foods for freezing.

The Court: What do you mean by "domestic" in that connotation?

The Witness: I mean the carton was designed primarily for use by the housewife in the home freezing or locker freezing of foods, much as in the same light as home-canned foods.

Q. (By Mr. Russell): Referring then specifically, Mr. Poole, to tab 7 in the art book, Defendant's Exhibit B before you, the patent to Hill which you indicated you have read before, [121] does not——

A. Pardon me. Did I understand you right, that I indicated I had read before?

Q. You indicated you had seen the patent before. A. I have seen the drawing only.

Q. Let me finish the question.

The Court: I understood he testified he had seen the patent, which had been shown him by counsel last week. But he had not read the specifications or the claims.

Mr. Boettcher: This week. That is correct.

Q. (By Mr. Russell): With reference to the patent to Hill, is there anything in your structure just described that is not in Mr. Hill's disclosure?

Mr. Boettcher: I object to the question. The Hill patent is not prior art and it is not a proper question, to compare the Poole disclosure, patent dis-

(Testimony of William J. Poole.)

closure, with something that is not prior art, in the respect of the question of validity.

Mr. Russell: I submit, your Honor, the Hill patent is prior art in this case, and if you desire us to brief it we shall.

The Court: What is it that makes it prior art?

Mr. Russell: The Hill patent, you will note, your Honor, was filed on October 3, 1947, as is clearly indicated on page 1 of the specifications. Whereas the patent in suit to Poole was filed May 10, 1948; nearly seven or eight months later. [122]

The Court: Does the filing date control or is it the issuance date of the patent?

Mr. Russell: Actually, your Honor, the filing date is presumably, the filing date of Hill being ahead of Mr. Poole's, presumably the Hill patent was prior art.

The Court: Well, it would have brought them into interference if they were in the Patent Office at the same time.

Mr. Russell: If the Patent Office had functioned properly, yes, your Honor. We submit perhaps they erred in not declaring interference. We will get to that point shortly.

Mr. Boettcher: May I speak to that?

The Court: Yes.

Mr. Boettcher: I am looking for a citation I had. This is in handwriting. I will do the best to read it as rapidly as I can.

The Court: Take your time. If you try to go too fast you will stumble. Don't rush. If you have

(Testimony of William J. Poole.)

to stay after the regular court hours, I will stay with you.

Mr. Boettcher: "A patent cannot properly be cited as an anticipation of a later patent granted on an application filed before the issuance of such earlier patent."

That is *Johns Pratt Company v. E. H. Freeman Electric Company*, 201 Fed. 356, on page 360.

I think that went to the Supreme Court, 345 U.S. 976. [123] And that is also consistent with the statutes, part of which Mr. Russell read a little earlier. He read from Section 102 of Title 35, which states, "That a person shall be entitled to a patent unless" this, that and the other thing. In other words, unless there had been public use prior to the invention or more than a year prior to the filing date, and so on.

I shan't go over all that at this moment, because I am leading up to Section 103.

"A patent may not be obtained, though the invention is not identically disclosed or described as set forth in Section 102 of this Title, if the differences between the subject matter sought to be patented and the prior art are such that the subject matter as a whole would have been obvious at the time the invention was made to a person having ordinary skill in the art to which said subject pertains."

Thus Section 103 makes it quite clear that Section 102 has to do with an anticipation, something earlier that is the same construction.

(Testimony of William J. Poole.)

But when the question is one of patentable quality of a difference between an invention and something that came before, then the prior art is referred to. And the prior art means knowledge, common knowledge. It doesn't mean by one person or by a file wrapper in the Patent Office, indeed.

The prior art, the words "prior art" aren't used in 102 at all. That has to do, I say again, with when the earlier thing is submitted as the same invention and earlier. But when it becomes, in order to measure the patentable quality of something that arrives later over something that existed earlier, that is the prior art. And the prior art is that which is known.

From this, your Honor, you can see why in this Johns Pratt case it should have been said:

"A patent cannot properly be cited as an anticipation of a later patent granted on an application filed before the issuance of such earlier patent."

Now, in this case we have this Hill patent. True, it was filed earlier than Mr. Poole's patent. If the inventions were the same, as your Honor indicated a little while ago, then there should have been an interference. But the inventions, so far as the issued patents are concerned—and that is about as much as I know about the Hill patent—weren't the same. And therefore the Patent Office didn't declare an interference.

I can read a claim of the Hill patent and I can tell your Honor, if it were in point, what that claim

(Testimony of William J. Poole.)

were directed to. The six claims of the Poole patent are directed to something different. [125]

Now, if, as a matter of fact, Hill made the invention, at least prima facie, on the day that he filed the application, it has no bearing whatever on the Poole patent because they are different inventions; the claims are different.

I have to go back again to say why this is as it is. The philosophy of the statutes I just read and the philosophy of this case, when you measure an advance you have got to measure the advance from something that exists. And something that exists, to be prior art, must be available to all, so far as the knowledge of it is concerned. That is the base line from which any invention is made.

Now, there was no such base line at the time of the issue of the Hill patent. I submit that the Hill patent is not prior art, and I will meet that now or at any time in this case.

Mr. Russell: May I be heard briefly?

The Court: Yes.

Mr. Russell: I have located a case in point. *Lemley v. Dobson-Evans Co.*, 243 Federal Reporter, page 391. This was a patent infringement case and it involved substantially the same subject matter we have here, as to whether or not a patent having an earlier filing date may be considered. I will quote at page 395:

“This court held, in *Drewson v. Hartje Co.*, supra, 131 Fed. at page 739, \* \* \*” I will omit [126] \* \* \* that a patent, the filing date of which ante-

(Testimony of William J. Poole.)

dated the filing date of the patent in suit, was, prima facie, anticipatory; and we have repeatedly accepted and applied that rule.”

Citing many cases.

Then continuing in that case on page 396: “Hence, it assuredly follows that if a patent in suit was applied for January 15th, and there is nothing to carry the patentee’s invention back of that date, and if a patent disclosing the same invention was issued to another in July upon an application filed January 1st, \* \* \*”

that is just 15 days’ difference——

“\* \* \* this tends to show that the patentee of the patent in suit was not the first inventor.”

The court continues:

“This has been distinctly held not only in *Drewson v. Hartje*, supra, but by the Seventh Circuit \* \* \*”

and many cases are cited.

The court continues:

“\* \* \* and it has been expressly recognized and applied by the Supreme Court (*Pope Co. v. Gormully Co.*, 144 U.S. 238, \* \* \*)”

Mr. Boettcher: May I reply?

The Court: Yes. [127]

Mr. Boettcher: Two words that were used in what has been read demonstrate my point.

The first one was “anticipatory”. An anticipation is an earlier thing of the same thing that someone produced later. That is an anticipation.

“The same invention” is in that language that

(Testimony of William J. Poole.)

Mr. Russell read; "the same invention" granted. Hill's filing date would be a factor if it were the same invention.

Anticipation is one thing. Inventive quality over something, that is something else.

When you measure the contribution or the value—the inventive quality, is the best way I can put it, over something that went before—does it or does it not contain, does it or does it not amount to an invention? That is over the prior art. That isn't what Mr. Russell's authority has to do with that. That has to do with an anticipation, and that means the same invention.

I might also say, in passing, if this were proposed here as the same invention, then it should have been pleaded. You have to plead a prior invention by someone else.

I think I will say no more, after I have said we are measuring here the contribution over the prior art, which is something else.

Mr. Russell: It is immaterial to us, your Honor, what you call it. The point we are trying to get over is that [128] Mr. Hill was earlier in time, and being earlier in time, regardless of whether it is drawn on the wall or drawn on a piece of paper, Mr. Hill had an earlier conception of the subject matter. Perhaps Mr. Hill failed to claim it, but he disclosed it and it is, in our opinion, prior art. We think it is very pertinent.

The Court: Is your Exhibit B in evidence?

Mr. Russell: Yes, your Honor.

(Testimony of William J. Poole.)

The Court: Well, the court will have to consider it along with the other evidence. I don't know which side of this question I will ultimately come to, but I am not going to precipitantly undertake to do so now.

I do think that the question put to this witness is argumentative in quality, and the objection is sustained.

Mr. Russell: In connection with the patent to Hill, your Honor, I may add that I have ordered by telephone, through our associates in Washington, a certified copy of the file wrapper and contents of the Hill patent, which I proffer to the court at this time. As soon as it is received I certainly shall appreciate the privilege of filing the same in evidence in this case.

The Court: I take it there is an objection on the same ground——

Mr. Boettcher: Yes.

The Court: ——as heretofore made? My suggestion would [129] be that it be deemed offered, and the court will rule on that offer when we next meet.

Mr. Boettcher: I was going to say, I am objecting to it on the same ground, but I think it is best that the court have everything before it.

The Court: Of course, I have had cases here, and we had a case concerning an improved machine for leveling cement sidewalks and things of that kind, a troweling device. They brought in as prior art a rather crude machine which embodied the



(Testimony of William J. Poole.)

same principle, which was used by some illiterate, semi-illiterate Mexican workman who was doing working of that character and had developed the machine for his own use. He never thought of patenting it or vending it to others. After using it for a number of years he had reached the age of retirement and he retired and left it in his garage.

They dug it out and brought it in here as prior art. There was a lot of evidence to the extent to which it had been used and disclosure had been made. I can't recall there was an objection to that as prior art. Everyone took the position that whether it was prior art or not depended upon whether it had that quality and there had been disclosure of it to someone, either the Patent Office or the public, competitors or someone. And the point they went at was it was not the same invention.

Now, either some very capable lawyers missed the point [130] in that case or you are arguing something which is not valid in this one; I don't know which. And I just can't decide it here at 20 minutes to 3:00 on Friday afternoon, when it comes to me cold.

Mr. Russell: May I continue, your Honor.

The Court: Yes.

Q. (By Mr. Russell): Mr. Poole, again referring to your structure, what is it that produces any unusual and surprising consequences, up and over older types of containers and closures thereof?

(Testimony of William J. Poole.)

Mr. Boettcher: I object to that kind of a question to a lay witness. "Surprising, unusual". That is lingo from the patent decisions, and we are not—why not just talk about the facts?

The Court: The objection is overruled. But I will not consider the words used by the witness as words of art. I think it is a proper question to put to an inventor, and the words will be understood in their usual meaning, rather than any specialized meaning which they might have acquired in the language of decisions.

Mr. Russell: Prevail upon the witness to use his own words, your Honor.

The Witness: Your question was what was unusual or surprising in this construction? Did I understand you correctly? [131]

Mr. Russell: Miss Reporter, will you read the question?

(The question was read.)

The Court: Do you understand the question?

The Witness: Yes.

The Court: All right. Just take your time and think about it and give your answer.

The Witness: Well, first of all, as to previous containers for this purpose, I don't claim to have any complete background of knowledge of all types of containers.

So perhaps I don't qualify as an expert on this. But I am sure that is not what I am up here for.

This container was developed to serve a definite requirement, which I believe was brought out in the

(Testimony of William J. Poole.)

testimony yesterday. That requirement having been brought to our attention by the comments and some objections from the users of the package that preceded it. And I know, or, I should say I knew at that time of no such container as this, which would accomplish the desired purpose of storing and properly freezing—I should reverse that—freezing and properly storing food products, and which would also offer the advantages of a rigid setup container with a full top opening that was simple to fill, simple to form a suitable closure and easy to empty after thawing, which could be nested to effect a saving in storage space and the freight.

At the time this idea was conceived and developed there [132] was no such container that answered those requirements.

Q. (By Mr. Russell): That is in sum and substance summarizing the unusual or surprising consequences arising out of the creation of your construction, is that correct?

A. Well, let me say that those things were the inspiration for developing this combination carton and plastic lid.

The Court: What he is getting at is what did you get when you started to develop it? What did you develop, from the standpoint of consequences that were not consequences of use of the earlier structures?

The Witness: May I say this carton, as such,—(indicating)—

The Court: You are referring to Exhibit 20?

(Testimony of William J. Poole.)

The Witness: Exhibit 20. Or this carton, Exhibit 16, which are essentially functionally the same. A carton of that nature, suitable for the packaging and storing of frozen foods, did not exist prior to the conception and development of this idea.

Q. (By Mr. Russell): The carton itself, however, is not patented, per se?

A. Well, let me say I don't know that, because again I am not a patent expert, sir.

Q. Getting to essentials, Mr. Poole, so far as you were concerned at the date of issuance of your patent, the [133] only point of novelty that you had, if any, was in the widening of that groove in the lid, isn't that correct?

A. Again I don't think I can give you a factual answer to that, because I am not able to interpret the legal language of the six claims.

Q. Apart from what the claims say, you created something, something that apparently or purportedly is new.

Now, as far as you were concerned, the only thing that was new was merely opening up the groove in the lid?

A. So far as I am concerned, still the specification as it reads, which is a combination or the creation of a new article for manufacture,—

Q. The box is old, isn't it?

The Court: Let the witness finish his answer.

Q. (By Mr. Russell): I beg your pardon.

A. —the creation of a new article for manufacture, to serve a given desired purpose. That

(Testimony of William J. Poole.)

situation had not changed between the filing date and the issuance date of the patent.

Q. Wasn't it essentially your problem to develop a plastic lid to fit an old conventional type of container, such as the milk container referred to before?

A. No, essentially the problem was to devise a combination of carton and lid which would perform this specific function, which combination did not exist prior to the [134] development of this idea.

Q. You testified that Plaintiff's Exhibit No. 16—that is the old carton body in front of you—was originally designed by you or put together by you, and then you designed the lid to go on top of it. It didn't work for some reason or other and thereafter you opened up the groove in the lid. Is not that the point of novelty or what you believe to be the invention, your contribution?

A. I still go back to the thought that the basic contribution was a workable combination of two elements of the patent.

Q. It was just to put the two parts together so they would fit?

A. So that they would—yes, so that they would fit and make a suitable, usable package.

Q. Now, just what does the opening of the groove, or providing an offset, as the case may be, do that wasn't accomplished before you conceived of it, as far as you know?

(Testimony of William J. Poole.)

A. Well, maybe I had better understand that question a little bit better, sir.

Q. I will rephrase it. When you widen the groove in the lid, what does it do?

A. Well, I believe it was brought out in the direct examination yesterday our first 3,000 trial lids——

Q. You are not answering the question. What does the [135] widening of the groove do? Isn't it a fact that it merely is widened to accommodate the lap joint?      A. That is correct.

Q. Very well. Do you personally know Mr. Hill, the patentee of the Hill patent referred to in Defendant's Exhibit B?

A. I have met him, yes, sir.

Q. When did you meet him?

A. To the best of my knowledge, my first meeting with Mr. Hill was on the visit referred to in the direct examination.

Q. Did he show you one of his lids?

A. No, sir.

Q. He didn't acknowledge to you he had invented a plastic lid?      A. No, sir.

Q. I didn't quite hear you?      A. No.

Q. Was he involved at all in connection with your negotiations with Crown Cork respecting the manufacture of your lids?

A. Yes, he was. As president of that company, he was definitely involved.

Q. At the time you conceived of your invention, Mr. Poole, did you believe that you originated the

(Testimony of William J. Poole.)

broad concept [136] of widening the groove in a lid to make it fit the lap joint of a container?

A. Could I have that clarified to this extent: Do you mean the time when, that I started to develop the idea of the combination of the two items, the necessity for a full open top plus a lid?

Q. Let's go to the time when you found out that the first type of lid wouldn't fit, and you had to widen the groove to make it fit. At that time, when you conceived the alleged invention, did you believe that the broad concept of widening that groove was original with you?

A. I am afraid I can't answer that, either, because I don't have complete knowledge of what may have gone on before.

Q. What you believe. This is your own subjective mind. Did you yourself believe that you were the inventor?

A. Well, let me answer it this way: I didn't know of no other.

Q. You didn't know of Mr. Van Saun's construction?

A. No. The first reference I have heard to the Van Saun patent was made by yourself here in this courtroom.

Q. Do you know Mr. Van Saun?

A. I have met Mr. Van Saun.

Q. Have you worked with him?

A. No, sir, I have not.

Q. Have you seen any of the structures he has created? [137]

(Testimony of William J. Poole.)

A. No, sir, I have not. He works for a different division of my company.

Q. Have you ever discussed patents with Mr. Van Saun?      A. No, sir, I have not.

Mr. Russell: I am attempting to hurry this as fast as I can, your Honor.

The Court: You don't have to turn the pages that fast. I am not rushing you.

Q. (By Mr. Russell): Mr. Poole, why doesn't Container Corporation, the plaintiff here, suggest the use of old cut-off milk cartons for the storage of foods and merely sell the lids?

Mr. Boettcher: I suggest that that is entirely speculative.

The Court: Irrelevant and immaterial. This witness is not qualified to give an answer.

Mr. Russell: I believe he is, your Honor. He was in that capacity, frozen food division of the Container Corporation.

The Court: The Court holds, in the present posture of the case, he is not qualified to determine corporate policy. Objection sustained.

Q. (By Mr. Russell): Is there any reason, to your knowledge, why the plaintiff, Container Corporation, does not make its commercial cartons and lids precisely as in accordance [138] with your patent?      A. Would you restate that, please?

(The question was read.)

The Witness: I presume that you refer to the change that was made in the 1950 version of this carton and lid, whereby we incorporated a 45-degree



(Testimony of William J. Poole.)

taper from the corner on the glue lap and the triangular recess in all four corners, as opposed to the previous or 1949 version. Is that correct?

Q. (By Mr. Russell): Yes.

A. The reason for that change and the reason we continued to manufacture the later style which was introduced in 1950 is because we feel it is a definite improvement. It makes for a simpler, easier closure operation by the housewife who uses the package.

Q. Handing to you, Mr. Poole, Plaintiff's Exhibit 23 in evidence, do you recognize that plastic lid?

A. Yes. Samples similar to this were shown to me by Mr. Boettcher a matter of about ten days ago.

Q. You had not seen a sample prior to that time? A. No, sir, I had not.

Mr. Boettcher: May I have the question and answer there, please?

(The record was read.)

Q. (By Mr. Russell): Since you first were advised of the existence of that particular lid referred to, that is, [139] Plaintiff's Exhibit 23, do you have any idea what they sell for?

A. No, I do not.

Q. What does the plaintiff, Container Corporation, sell its lid for to wholesalers?

Mr. Boettcher: I object to that. I don't see any reason for prying into the financial affairs.

The Court: Sustained.

(Testimony of William J. Poole.)

Q. (By Mr. Russell): Mr. Poole, what is the gross business done by the plaintiff, Container Corporation, in the manufacture and sale of plastic lids, the type here in suit?

A. Are you asking for an average annual gross? Is that what—

Q. Yes. Pick any year as exemplary.

A. Assuming the value at resale, which we established it, approximately five cents—

Q. Just a minute. You are not answering the question.

The Court: He is giving an explanation of terms, apparently, from which we will understand the answer he is about to give.

Mr. Russell: Very well, your Honor.

The Court: So he may continue to do that.

The Witness: Assuming the retail value at approximately five cents, it is a matter of arithmetic to establish the annual gross business at the retail level on these lids. And [140] we have already, I think, been told that we were not to disclose the wholesale price these are sold to the distributors at, by the sustaining of the objection of Mr. Boettcher.

The Court: The question doesn't require you to do that. I take it the question could be answered if you told the approximate number that were placed into commerce in a year's period of time or in some other unit of measurement.

Mr. Russell: The monetary value is important, your Honor.

The Court: Why?

(Testimony of William J. Poole.)

Mr. Russell: Commercial success. What is commercial success, which is an important issue in this case.

The Court: I don't think the percentage of profit and so on—that is the sort of thing you are beginning to get at. You haven't asked exactly that, but you have asked a question which would lead readily into that field, and that I don't think the Court should inquire into. It is beginning to get into the private, confidential information of the litigant.

Mr. Russell: I submit, your Honor, that I could manufacture and distribute these items myself. I could give them away. I could give away millions of them, perhaps, and not be commercially successful.

The Court: I think commercial success, used in the language of patent laws, does not refer so much to commercial [141] economic success as it does to acceptance by a using public, or using segment of the public, a large number of the devices which are vended and which embody the invention or claimed invention.

Mr. Russell: Very well, your Honor. And the same, of course, would be true of the structures of the defendant's. If they infringed the patent in suit they should likewise be as commercially successful; I would presume the same would be true.

The Court: Commercial success is greatly overworked in these cases.

Mr. Russell: May I proceed, your Honor?

The Court: Yes.

Mr. Russell: Thank you.

(Testimony of William J. Poole.)

Q. (By Mr. Russell): To your knowledge, Mr. Poole, has a Dun & Bradstreet report been secured on the defendant in this case?

A. I would have no idea.

Q. You have before you, Mr. Poole, the Locker Management publication that, I believe, is Defendant's E, the two-sheet outside cover of the magazine or publication.

A. Yes, I do.

Q. Referring to page 2, will you kindly tell the Court wherein the patented feature is made known to the public in that advertisement of the plaintiff's? [142]

A. Well, I am not too sure I understand that question, either.

The Court: He wants to know where the salient features of the patent are illustrated or pointed out in that exhibit.

The Witness: Not necessarily the fact it is patented, however, is that right?

The Court: No. He is referring to structural or functional characteristics, as distinguished from sales language or claim of title to a patent.

The Witness: I can't say that specifically there is any language used in the copy of this page——

Q. (By Mr. Russell): Nothing to show the widening of the groove?

A. ——which refers specifically to a patented container.

Q. Isn't it a fact, Mr. Poole, that cartons of the type of Plaintiff's Exhibit 20 before you, the commercial embodiment, may be used for other pur-

(Testimony of William J. Poole.)

poses besides in conjunction with the plastic lid of the Plaintiff's Exhibit 21?

A. By that do you mean that——

Q. Couldn't a housewife put a piece of aluminum foil around it and wrap a rubber band around it to store food in a refrigerator?

A. That is possible. That could be done, yes. I doubt it would be as efficient.

Q. It can be done without the lid? [143]

A. I don't think there is any question about it.

Q. Does the amount of advertising done by the plaintiff, in advertising its Vapocan—and I refer to both of them—have any effect on the sales of the item, to your knowledge?

A. I am afraid that is something I wouldn't be able to judge. I don't have access to any market survey figures. I don't have access to the amount of moneys that are spent on advertising, so I am afraid I can't answer that.

Q. Have you ever read the file history of your patent?      A. No, sir, I have not.

Q. In fact, you don't know what you invented?

Mr. Boettcher: Oh, I think this argument with the witness is wrong.

The Court: Are you objecting?

Mr. Boettcher: I am objecting.

The Court: Sustained.

Q. (By Mr. Russell): Do you or your company, Mr. Poole, claim to have any right to prohibit other people from making or using a plastic lid having a

(Testimony of William J. Poole.)

peripheral groove such as any before you, without the widening of the groove?

A. I am afraid that is something I would have to refer to our legal department for an answer.

Q. The same thing would be true as to prohibiting other people making or using a lap-jointed carton? [144]

A. If it were a question of whether I felt that my company could prevent any other manufacturer from making a given carton or lid, or anything else, I would not feel I could judge that. It again would be referred to my legal department for an answer.

Q. Without disclosing, Mr. Poole, any monetary figures which might be confidential, what is the percentage of the gross volume of business done by the plaintiff, Container Corporation, as compared to the gross volume of business on the lids and cartons now in issue, percentagewise?

A. Oh, I am afraid that would be grabbing in the air for a figure, if you would like to have me guess.

The Court: No, we don't want guesses.

The Witness: I am afraid I couldn't answer it then.

The Court: Estimate, yes. If you can estimate, all right. But an estimate is an educated guess, and we don't want wild guesses.

Q. (By Mr. Russell): Could you make an estimate?

A. I am afraid it would fall in the category of a guess, so perhaps I better not.

(Testimony of William J. Poole.)

Mr. Russell: I believe that is all, your Honor, for this witness.

Mr. Boettcher: I would like to ask a few questions on cross.

The Court: Yes. [145]

Cross Examination

Q. (By Mr. Boettcher): Referring to Defendant's Exhibit E, I notice the first few words on that page, that is, the inner cover page, about the Vapocan are as follows:

“Only Vapocan Has All These Fine Features \* \* \* Full-Top Opening For Easy Filling And Emptying.”

You mentioned that some time ago, didn't you, yesterday, for instance?

A. That is right.

Q. “Plastic lid can be used year after year, a thrifty long-range investment.”

You have read the specification of your patent?

A. Yes.

Q. It says something about reusable covers, does it not? A. Yes, it does.

Q. “Sure, efficient seal in one quick motion.”

Didn't you speak about that yesterday?

A. Yes, sir, that is also in the specifications.

Q. You are talking about the pressure of the housewife's hand on the cover? A. Yes.

Q. “Squared body saves locker and storage space.”

You mentioned that yesterday? [146]

(Testimony of William J. Poole.)

A. Yes.

Q. "Plastic lid rimmed for firm stacking."

That is another way of saying it? You talked about stacking yesterday?

A. That is right, yes, we did.

Q. What are your present responsibilities with the Container Corporation?

A. I am manager of beer package sales of the Chicago carton division.

Q. Beer package sales of a particular division?

A. That is right.

The Court: What kind of package?

The Witness: Beer.

The Court: Beverage?

The Witness: Yes.

Q. (By Mr. Boettcher): It means cartons for six bottles of beer or something of the sort, is that right? A. That is correct.

Q. How long have you been manager of that particular division or section?

A. I believe the date I took over that responsibility and title officially was April 23, 1953.

I have been working, however, partially on beer packaging somewhat prior to that, starting in about 1951.

Q. In other words, you moved gradually from the frozen [147] food packaging into the beer packaging, is that right?

A. That is correct. And I carried responsibility in both for that change-over period.

Mr. Boettcher: Nothing further.



(Testimony of William J. Poole.)

Mr. Russell: A question, your Honor, if I may.

The Court: Yes.

Redirect Examination

Q. (By Mr. Russell): You brought out the fact you are connected with the beer packaging division of the plaintiff.

A. That is correct.

Q. The last fiscal year, how many beer cartons were delivered out of the beer packaging division?

Mr. Boettcher: I object to that as utterly immaterial.

The Court: Sustained.

Mr. Russell: I submit it is not.

The Court: What makes it material?

Mr. Russell: Trying to establish what constitutes commercial success with something to compare it with. He has testified that they sell millions of these cartons that are here in issue.

I believe it is material to show what other products are sold in tremendous mass quantities. Not because they are patented, but just because they happen to be a paper box.

The Court: You are getting then into the realm of [148] common knowledge, aren't you?

We know that a tremendous number of items enjoy huge commercial success. Many of them that are not the subject of patent and never have been.

Mr. Russell: Are you going to rule on the question, your Honor?

The Court: The objection has been sustained.

Mr. Russell: Thank you.

(Testimony of William J. Poole.)

Mr. Boettcher: I concluded my cross examination.

Mr. Russell: Very well, Mr. Boettcher. The witness may be excused, so far as the defense is concerned, your Honor.

(Witness excused.)

Mr. Russell: I would like to call Mr. Comstock to the stand, if I may. If your Honor desires a very short recess, why, we may enjoy it and Mr. Boettcher may enjoy it.

The Court: All right. We will take a short recess.

(Recess taken from 3:17 o'clock p.m. to 3:32 o'clock p.m.)

Mr. Russell: I would like to offer in evidence Defendant's Exhibit F for identification.

Mr. Boettcher: I object. There is no foundation.

The Court: I do not recall the foundation.

Mr. Russell: Beg your pardon, your Honor?

The Court: I do not recall the foundation.

Mr. Russell: The witness, your Honor, was interrogated and he did indicate that he recognized the subject of the [149] display, but not the particular piece of paper.

The Court: Well, is it offered then as illustrative of the witness' testimony concerning the structure that is shown there, or is it offered for something else?

Mr. Russell: Yes, your Honor.

Mr. Boettcher: I don't understand the testimony he is talking about.

Mr. Russell: The testimony of Mr. Poole. The fact display stands are made and distributed by the plaintiff.

Mr. Boettcher: I think it could be submitted only for the purpose of identifying the picture in the right-hand corner here, or something of that sort.

The Court: That is what he is doing. And if this were a jury case I would have the clerk paste some tape over the rest of it. Since it isn't, I will just not bother to read the rest of it myself. It is received.

(The document heretofore marked Defendant's Exhibit F was received in evidence.)

Mr. Boettcher: I think the record will show its pertinency or its lack of it here.

Mr. Russell: Mr. Comstock, your Honor, has approached the witness stand. I would like to have him sworn as a witness. [150]

### ROBERT C. COMSTOCK

called as a witness on behalf of the defendant, having been first duly sworn, was examined and testified as follows:

The Clerk: Will you please be seated.

Your name, sir?

The Witness: Robert C. Comstock.

#### Direct Examination

Q. (By Mr. Russell): What is your occupation, Mr. Comstock?

A. I am a patent lawyer.

Q. And your business address?

(Testimony of Robert C. Comstock.)

A. 4055 Wilshire Boulevard, Los Angeles.

Q. Are you admitted to the State Bar of California? A. Yes, I am.

Q. Any other state bars?

A. Yes, I was admitted in Illinois in 1941.

Q. Admitted to practice before the Patent Office? A. Yes, I am.

Q. How long have you practiced patent law?

A. Since 1941, except for time in the Service.

Q. And you in your practice of patent law have prepared patent applications?

A. Yes, I have, many of them.

Q. And prosecuted patent applications before the Patent Office? [151] A. Yes, I have.

Q. And has this been on various and sundry mechanical patent applications? A. Yes.

Q. You are, therefore, familiar with Patent Office procedures and actions made by Patent Office Examiners? A. Yes, I am.

Q. Have you rendered legal opinions relative to the validity of patents and infringement of patents?

A. Yes, I have quite frequently.

Q. Have you appeared before the Patent Commissioner on various patent matters?

A. Yes, I have.

Q. Have you testified as an expert before any patent cases? A. Yes, I have.

Q. Have you studied the patent in suit to Poole, No. 2,638,261?

A. Yes, I have studied that patent.

Q. Have you studied all of the patents in the

(Testimony of Robert C. Comstock.)

Defendant's Exhibit B, the seven patents heretofore referred to?

A. Yes, I have studied all of those.

Mr. Russell: I believe, your Honor, you have been advised of the subject matter of the patent in suit. I would like to proceed directly to the art book, and particularly the [152] patent to Drake, which is identified as tab No. 1. I believe your Honor has your copy.

The Court: Yes. Referring to Defendant's B?

Mr. Russell: Defendant's B, your Honor, yes.

Q. (By Mr. Russell): You are familiar, Mr. Comstock, with the contents of the Drake patent?

A. Yes, I am.

Q. Do you find any similarity between the disclosure of the Drake patent and the disclosure of the Poole patent in suit?

A. Yes, the Drake patent shows a container which it states is made of fibrous material, which would include paperboard of the type described in the Poole patent, and the lid, which is described here as being circular rather than square as in the Poole patent. But the lid is similar in the way it fits on the container. The lid in the Drake patent—the patent states that it is

“preferably tapered so that by reason of such taper the ring 11 wedges to the exterior of the neck surface or tightens as it is forced on.”

I was reading from around line 105 in column 2 on the first page of the patent.

(Testimony of Robert C. Comstock.)

And a little later on, around line 110, it refers to "a very acute V-shaped groove", and that structure is shown in Figure 2 of the patent, in which it shows that the top of [153] the container is wedged into a narrowing or tapering groove that is defined by a pair of flanges of the container.

Q. Do you find anything to the effect that there is a sealing action between the container and the closure illustrated in Drake?

A. Yes; referring to the next page of the patent, page 2, line 7, and continuing on, he states:

"a continued forcing of the closure will cause the yielding material of the receptacle to be compressed into the V-shaped groove thereby forming an absolutely air and liquid tight joint between the closure and the receptacle."

Q. That is comparable, or, let's say identical to the type of closure represented by the Poole patent in suit?

Mr. Boettcher: Here we have an expert on the stand, your Honor please. I don't think we should ask leading questions of the expert.

The Court: Well, experts of this character in testifying are lawyers themselves, and you get an advocate's answer just the same as if he were asking the questions in leading form.

I don't mean to disparage patent experts, but they have one of their lawyers on the stand, is what it amounts to.

Mr. Boettcher: I understand. I thought I would

(Testimony of Robert C. Comstock.)

raise this objection at the first instance and then forever hold my [154] peace on that kind of an objection.

The Court: The testimony does have its limitations for that reason, but still I think it is an almost indispensable type of procedure for defendants in this type of case. We always have it, so the objection is overruled.

The Witness: Will you read the question?

(The question was read.)

The Witness: Yes, the sealing or closure action described in the Drake patent is the same as that described in the Poole patent. That is, the carton, top edge of the carton is sealed or compressed within the tapering groove.

Q. (By Mr. Russell): If I may refer, Mr. Comstock, now to Claim 1 of the Poole patent, I will quote in part:

“a plastic friction cover having a downwardly opening peripheral recess tapering upwardly,”

Do you find such construction in the Drake Patent, tab No. 1?

A. Yes, the recess there is downwardly directed and it tapers upwardly.

Q. Also further quoting from Claim No. 1:

“fitting tightly over the upper edge portion of the wall of said body with the opposed surfaces of said recess contacting the inner and the outer surfaces of said wall for the major portion of the depth of said recess and compressing said wall between said

(Testimony of Robert C. Comstock.)

opposed surfaces thereby providing a tight friction [155] seal between said cover and said body.”

Do you find that construction in the Drake patent?

A. Yes. Taking the first part of that first, you find the first part of it shown in Figure 2 where you see that the top of the container is tightly fitted, and that that continues for the major portion of the depth of the recess.

And then the later part about the tight fitting or compressing is set forth in the specification where it states that the top of the container is compressed into the V-shaped groove to form an air and liquid tight joint.

So that I find all of the structure which you read from Claim 1 of the Poole patent is shown and described in the Drake patent.

Q. Let's skip then to Claim No. 5, and quoting from a portion of it, it says:

“having a peripheral member comprising an inner flange and an outer flange, said flanges diverging downwardly and defining between them an upwardly tapering recess for frictional engagement over the upper edge portion of the wall of the carton body,”

Do you find such a construction in the Drake patent?

A. Yes, all of that structure is shown. We have the recess which is defined between elements 11 and 13. I believe 11 is referred to as a ring and 13 is re-



(Testimony of Robert C. Comstock.)

ferred to as a sleeve. Between them they form the downwardly directed recess. The [156] specification says it is tapered and the drawings show that it is tapered, particularly in Figure 2, which is larger than Figure 1.

Mr. Russell: In view of the similarity of these claims, your Honor, and in view of the interest of progressing with the trial, we will skip reference to the other claims which your Honor may desire to evaluate while the subject matter is under submission.

Q. (By Mr. Russell): Do you find any particular material that Mr. Drake used in the construction of his lid?

A. He states:

“The closure comprises a disk of any convenient or desired material such for instance as very light weight sheet metal die-stamped to form a ring 11”, so that he states it can be any material, but he specifically mentions metal.

Q. Let's refer, Mr. Comstock, to the tab No. 2, the patent to Kurz — K-u-r-z — identified as No. 1,969,486. What does the patent to Kurz disclose in general?

A. Kurz shows a shaker, which is formed of a synthetic molded plastic material and a cover or lid which is also formed of a molded plastic material.

Q. Do the claims of the patent to Kurz refer to the material employed?

A. Yes, Claim 1 of the Kurz patent states: [157]

(Testimony of Robert C. Comstock.)

“a closure therefor of convex dome shape, also of molded synthetic resinous material”.

Q. So the cover of the patent to Kurz is made of a molded plastic material? A. Yes.

Q. Referring to the next patent, Mr. Comstock, the patent to Rutkowski, No. 2,155,022, is there any similarity in the construction disclosed by Mr. Rutkowski and that of the Poole patent in suit?

A. Rutkowski shows a container which is designated by the reference character 1, which it states may be any

“suitable such, for instance, as cylindrical, oval, oblong, square,”

and then there is a cover which fits on the container, and he states that he provides

“a slip closure embodying two cover portions having spaced depending flanges adapted to frictionally engage the outer and inner walls of a tubular paper container body”.

The structure that is similar to Poole's or closest to Poole's is shown in Figure 7 of the patent, in which it shows the top of the container, paper container, being wedged or compressed within a tapering recess.

Q. Wedged in the same manner as described in the claim of the patent to Poole? [158]

A. Yes; the inventor states, referring to page 2 of the specification, around lines 49 and 50:

“a substantially wedge-shaped recess or can body

(Testimony of Robert C. Comstock.)

wall receiving space 15' between the closure flanges 5 and 7''.

And a little later on, at the end of that paragraph he states:

“that the wall material of the can body is compressed when forcing the closure onto the end of a paper can body 1.”

This type of fit and compressing is the same as that shown and described in the Poole patent.

Q. So that the Rutkowski recess, for example, in Figure 7 referred to, the recess is a downwardly opening, tapering recess, is that correct?

A. That is right, the recess is directed downwardly and the tapering is directed upwardly to wedge the top of the container.

Q. Was the patent to Rutkowski cited by the Patent Office Examiner during the prosecution of the Poole application?           A. No, it was not.

Q. What class——

The Court: Was the Drake patent cited?

The Witness: Yes, your Honor, the Drake and the Kurz [159] patents were cited, and the Rutkowski patent was not.

Q. (By Mr. Russell): What class and subclass in the patent office is Rutkowski classified?

A. That is, 229 is the class and 5.5 is the subclass.

Q. And what is the class and subclass of the patent to Poole in suit?

A. That is the same class and subclass.

Q. Same identical class?           A. Yes, it is.

(Testimony of Robert C. Comstock.)

Q. In your opinion, Mr. Comstock, should not the Patent Office Examiner have cited the patent to Rutkowski against the Poole application?

Mr. Boettcher: I object to that.

The Court: Sustained.

Q. (By Mr. Russell): In your opinion, Mr. Comstock, the Rutkowski patent is a very pertinent prior art, is it not? A. Yes, it is.

Q. As against the Poole patent in suit.

A. Yes.

Q. Is it much more pertinent, in your opinion, than the patent to Drake?

A. I would not say much more. It is somewhat more pertinent, but they show very similar structures and similar action. It is a little closer in structure, because the Rutkowski refers to his container as being square and he [160] definitely defines it as being paper, and there are other points like that that are somewhat closer.

Q. Referring now to the Moore patent, No. 2,381,508, which I believe is tab No. 4, do you find any subject matter in the Moore patent in tab No. 4 similar to that of the Poole patent in suit?

A. Moore shows two types of containers. Referring first to the front page of drawings at the bottom, he shows a container in which there is a full overlap for one entire side of the container. And then he shows a second construction, that is on the following page in Figure 5, in which there is a lap joint which only extends for a part of the fourth side of the container. And then he shows a

(Testimony of Robert C. Comstock.)

cover which fits over the double thickness or the lap joint, as the case may be.

Q. Then there is a double wall thickness lap joint which is received into an increased width groove on the lid?

A. That is right. Referring to Figure 3 on the second page of the drawings, on the left side the recess is twice the width of that shown on the right side, the reason being that the recess on the left side accommodates a double wall thickness, where on the right side it accommodates only a single wall thickness.

Q. Does the left joint referred to extend to the upper edge of the container? [161]

A. Yes, it does.

Q. So Mr. Moore, therefore, discloses a concept of providing an angular groove for a lid, wherein the groove is widened to accommodate a double wall thickness carton due to a lap joint?

A. That is correct. The recess is shown most clearly in Figure 3, and the widening is shown in the left side of Figure 3.

Q. Let's refer to the Claim No. 1 of the Poole patent, wherein it states, and I quote:

“said recess being of increased width for a portion of its length corresponding to said lap joint and of uniform width for the remainder of its length.”

Do you find such structure in the patent to Moore?

A. Yes, that is true of Moore. He has a recess which is of increased width only sufficiently to fit around the lap joint, whether the lap joint is the

(Testimony of Robert C. Comstock.)

full side of the container or part of the side of the container, and then it is a uniform width for the remainder.

Q. Was the Moore patent, Mr. Comstock, cited by the Patent Office Examiner against the Poole application?      A. No, it was not.

Q. Was there any other patent or other reference cited by the Patent Office Examiner that showed a cover for a container, the cover having a peripheral recess and the recess [162] being widened to accommodate a container lap joint?

A. No, there was not.

Mr. Boettcher: Please read the question.

(The record was read.)

Mr. Boettcher: Other than what?

Read it again, please.

Mr. Russell: Refer back to the previous question.

(The record was read.)

The Court: We will recess *Container Corporation of America v. M.C.S. Corporation* for ten minutes, while we take a verdict in the *Keltz v. Ringling Bros.* case.

(Recess taken from 3:58 o'clock p.m. to 4:00 o'clock p.m.)

Q. (By Mr. Russell): Mr. Comstock, we were referring to the patent to Moore, tab No. 4, is that correct, in Defendant's Exhibit B?

A. Yes, that is right.

Q. What Patent Office class was the Moore patent classified?      A. Class 229, subclass 43.

(Testimony of Robert C. Comstock.)

Q. Now, referring to Class 229, is that the same class that the Poole patent in suit was classified?

A. Yes, it is.

Q. Do you consider the Moore patent as pertinent prior art against the Poole Patent in suit?

A. Very definitely pertinent. [163]

Q. In what respect?

A. Not only in the respect that it provides a downwardly directed recess, but more particularly because it shows a widening of that recess to accommodate a lap joint in a container, with the lap joint coming up to the top edge of the container and the lap joint fitting within the widened part of the recess.

Q. Was there any other reference cited by the Patent Office Examiner that shows the concept of widening a groove in a lid to receive a double thickness lap joint?

A. No, there was not.

Q. Let's refer now to the patent to Van Saun, tab No. 5, in Defendant's Exhibit B.

Do you find any similarity in the Van Saun patent as compared to the Poole patent in suit?

A. Yes, the Van Saun shows a body member 20, which comprises a rectangular sheet of strong paperboard or similar fibrous material, having its ends brought together in overlapping relation, and secured together.

Q. That is a lap joint?

A. That is a lap joint. That is referred to in the first page of the specification in the middle of

(Testimony of Robert C. Comstock.)

the second column and it is also shown in the drawings of the patent.

Q. Do you find any similarity in the construction of the closure of Mr. Van Saun respecting the closure of the [164] Poole patent in suit?

A. Yes, there is. Referring now to the first full paragraph at the top of page 2 in the first column, it states:

“The auxiliary disc 25 is intended to be secured centrally on the disc 24 and is so dimensioned as to provide an annular recess between the edge of the disc 25 and the down-turned tabs 27, 27. As shown in Fig. 1, this recess indicated at 30, is adapted to receive the end of the body member 20.”

So that we have the top edge of the body member 20 fitting into a recess 30, and then it states in the next paragraph:

“The disc 25 is suitably cut away at 31 so as to provide a slightly enlarged part in the annular recess 30, indicated at 32 so as to accommodate the extra thickness of the body member due to the overlapping of the ends of the body member. (See Fig. 6.)”

And then Figure 6, which is in the lower left-hand corner of the first page of drawings, shows there is a recess which is indicated by 32, which accommodates the lap joint which is not indicated by, but is actually at the end of the lead line of the references numeral No. 23. .

Q. So the broad concept of providing a widened portion in a groove of a lid to accommodate a lap



(Testimony of Robert C. Comstock.)

joint of a container is disclosed by Mr. Van Saun?

A. Yes, it is.

Q. And Van Saun's patent issued on what date?

A. It was issued on January 15, 1946.

Q. That was more than one year prior to the filing date of Mr. Poole's application?

A. The Poole application was filed on May 10, 1948,——

Q. More than one year——

A. A little over two years later.

Q. Do you find any claim in Mr. Van Saun's patent that claims the feature of widening the groove of a recess of a cover to accommodate a lap joint container?

A. The only claim which I found that might be considered to cover that structure would be Claim 13, which states:

“A drum according to Claim 9 including a second disc secured to the inner surface of said closure disc and so dimensioned as to provide an annular recess adjacent the periphery thereof adapted to receive one end of said body member.”

Referring back to Claim 9, the first words of Claim 9 state:

“A drum of paperboard or similar sheet material comprising a body blank having oppositely disposed edge portions secured together,”

If that were construed that they are fitted together to provide a lap joint, then the term “so dimensioned” there in [166] Claim 13 would necessarily mean that the cover would have to be dimen-

(Testimony of Robert C. Comstock.)

sioned to accommodate that. That is as close as this patent comes to claiming that feature.

Q. Have you examined the file wrapper of the patent to Van Saun? A. Yes, I have.

Mr. Boettcher: I am registering an objection to that, so that the record will show I am objecting to it.

Mr. Russell: The file wrapper of the patent to Van Saun, your Honor, is identified as Exhibit A.

Q. (By Mr. Russell): I hand you a certified copy of the file wrapper and contents of the Van Saun patent, Mr. Comstock, and ask you to point out in that file wrapper, if you can, wherein Mr. Van Saun attempted to claim the feature of widening the groove of a lid to accommodate the lap joint of an open-ended container.

Mr. Boettcher: Objection——

The Court: I am not sure about this. I see you are about to object, which would just be the logical sequel to the objection made this morning. And the objection is deemed made and overruled, but subject to a motion to strike, because if, when I finally rule upon whether to admit this wrapper, if I should decide to admit it, this witness might not be currently available. He is on the stand now, so let's let him answer so we will have a record of it. [167]

Mr. Boettcher: Well, I will make a motion to strike the exhibit from the case.

The Court: It hasn't been admitted yet, has it?

Mr. Russell: Yes, it has, your Honor.

(Testimony of Robert C. Comstock.)

Mr. Boettcher: Yes, that is what I understood this morning.

The Court: Yes, I recall it was admitted subject—

Mr. Russell: Subject to a motion to strike.

The Court: —to a motion to strike. We will admit this testimony subject to a motion to strike. I am inclined to think it is actually admissible, but I am not just absolutely sure about it, so I am not going to pay too much attention to the file wrapper or to these answers until I have read a bit on that.

Mr. Russell: I have a number of legal authorities here, your Honor, which I can adequately include in a brief.

The Court: I trust you are not going to read them to me this afternoon.

Mr. Russell: I understand that.

Mr. Boettcher: I think I would like to have the pending question read now.

The Court: Yes, read it, please.

(The question was read.)

Mr. Boettcher: My point is, what has that got to do with this case? [168]

The Court: I suppose it is an attempt to show prior art, in that he made a disclosure of such a concept to the Patent Office, and there was some—well, he made that disclosure. What they did with it might not be material here, but the fact he made the discloser, if it was of the same claim, would be evidence of prior art, wouldn't it?

Mr. Boettcher: Well, of course, the matter of

(Testimony of Robert C. Comstock.)

prior art would be a matter of disclosure, rather than what is being claimed. But I——

The Court: Well, isn't the claim as submitted to the Patent Office, either in the application for letters patent, where I don't suppose it would be a claim in the strict sense of a claim, but it is a proposal of a claim to be allowed, isn't that evidence of a disclosure, evidence of a concept as of the time that that was filed with the Patent Office?

Mr. Boettcher: If there is something disclosed in a prior art patent, it doesn't make any difference whether it is claimed or not. I would like——

The Court: He is not using the word "claim" in the technical sense.

Mr. Boettcher: Oh.

The Court: I take it that he means sought to obtain letters patent upon.

Mr. Russell: That is very good, your Honor.

Mr. Boettcher: Perhaps it would clarify my objection a [169] bit more if I referred to the fact that in my adversary's trial memorandum he refers to this file wrapper and contents of Van Saun and does so under the heading of estoppel. I don't understand it.

And if there is a particular purpose in using this file history as distinguished from the mere issued Van Saun patent, I would like to know what it is and I think the court should be apprised of that.

The Court: What is it?

Mr. Russell: I brought that out before, your

(Testimony of Robert C. Comstock.)

Honor. The primary reason for employing the file wrapper of the Van Saun patent is to show that the subject matter of the patent in suit, at least a part of the subject matter, was known to others before Mr. Poole conceived of his invention. And I paraphrased Title 35, I believe, Section 102 of the United States Code. That is affirmatively pleaded in our Answer.

The Court: I think this is admissible for that purpose.

Mr. Boettcher: Anything that Van Saun invented and disclosed, that wasn't stricken from the application, is represented by the issued patent on January 15, 1946.

Now, he either has something there in the way of anticipatory material or prior art, against which to weigh inventive quality, or he hasn't.

Why go back of the issue date of that patent? Anything that Van Saun contributed is apparently in that patent. [170]

The Court: Well, it might not have been deemed patentable material. Prior art doesn't consist only of issued patents.

Mr. Boettcher: Right.

The Court: If Van Saun made some disclosure in his application, I think that is admissible.

Mr. Boettcher: Perhaps. Of course, I haven't compared the Van Saun file wrapper with the Van Saun patent, but I should be a little bit surprised if there is any disclosure in the Van Saun application, the file history, that is not in the issued patent.

(Testimony of Robert C. Comstock.)

The Court: I am not weighing the evidence. I am just channeling it and admitting it at this time.

You might be right. It might be totally dissimilar, when we get down to an analysis of it.

Mr. Boettcher: I should be pleased to have this alleged estoppel explained to me. I don't understand it.

The Court: I can see some theories, but it would take a lot more evidence in order to piece them out.

The Witness: Claim 5 of the Van Saun application, as originally filed, stated:

“A drum according to Claim 4, wherein said second disc is provided with a cut-away portion adapted to form a slightly enlarged section of said recess for the reception of the overlapped portions of said body [171] member.”

Q. (By Mr. Russell): What disposition was made by the Patent Office Examiner respecting proposed Claim 5, referred to?

A. In an office action dated November 18, 1943, the Examiner stated:

“Claims 4 and 5 are rejected as unpatentable over Cody in view of Wright, who discloses a slip type closure having a disc secured to the inner surface to provide an annular recess. To form Cody's closure with a similar disc would lack invention. Such disc wouldn't obviously be shaped to conform to the cross sectional shape of the container end.”

Q. The Patent Office Examiner then deemed it as obvious to widen the groove in the construction presented by Mr. Van Saun?

(Testimony of Robert C. Comstock.)

Mr. Boettcher: I object to that.

The Court: Sustained.

Q. (By Mr. Russell): After the Examiner's action referred to, Mr. Comstock, did Mr. Van Saun argue that he should be allowed to Claim 5 as having the inventive concept set forth in Claim 5?

A. Yes. And in an amendment filed May 16, 1944, an argument was made with regard to Claims 4 and 5, and with [172] regard to Claim 5 in particular, it was argued:

"Claim 5 which is dependant upon Claim 4, should obviously be allowed along with the latter, and it should also be allowed for the reason that it requires that a portion of the second or inner disc be cut away so as to form a slightly enlarged section of the annular recess for the reception of the overlapped portions of the body member. The Examiner has attempted to dismiss this feature with the statement that the disc would obviously be shaped to conform to the cross sectional shape of the container end. It is submitted that the arrangement defined in Claim 5 is not at all obvious and that the most obvious procedure would be to make the recess sufficiently wide at all points to accommodate the overlapped portion of the body wall. If Applicant's arrangement were as apparent as the Examiner has stated, he should be able to find some reference which would illustrate it. It is believed that upon reconsideration, the Examiner will agree that the subject matter of Claim 5 is clearly and patentably distinct from the prior art."

(Testimony of Robert C. Comstock.)

Q. That was the argument of Mr. Van Saun, as you read it from the file wrapper?

A. That is right. That is the argument for reconsideration [173] as presented to the Patent Office.

Q. What was the subsequent action taken by the Examiner?

A. In an office action dated August 24, 1944, Claim 5 was again rejected. The Examiner stated:

“Claims 1, 2, 4, 5 and 6 are rejected on Cody in view of Eggers and Wright all of record and Roch et al. There would be no invention in providing staples for each of the tabs of Cody and in clinching them against the inner surface of the body member as taught at 8 and 9, respectively, Figs. 1 and 2 of Eggers, in securing a second disc to the inner surface of the closure disc as taught at 16, Fig. 4 of Wright, and in introducing a sealing compound into the recess as taught at 19, Fig. 3 of Roch et al. There would also be no invention in cutting away a portion of the second disc.”

Q. Then what action did Mr. Van Saun take?

A. In an amendment filed February 17, 1945, Claim 5 was canceled from the application.

Q. Did Mr. Van Saun personally prosecute his own application for patent? A. No, he did not.

Q. Who did?

Mr. Boettcher: I think that is immaterial, too. I object [174] to it.

The Court: Sustained.



(Testimony of Robert C. Comstock.)

Mr. Russell: I believe it is material, your Honor, if I may proceed.

The Court: The court holds it is immaterial.

Mr. Russell: Beg your pardon, your Honor?

The Court: The court holds it is immaterial.

Q. (By Mr. Russell): Does the file wrapper show, Mr. Comstock, to whom the Van Saun patent was assigned?

A. It was assigned to the Container Corporation of America.

Mr. Russell: Will you stipulate, Mr. Boettcher, that is the same Container Corporation of America as the plaintiff here in suit?

Mr. Boettcher: Certainly.

The Court: It would seem to indicate that they thought they were getting something new and additional.

Mr. Russell: At that time.

Q. (By Mr. Russell): From the foregoing facts, Mr. Comstock, is it indicated that the Container Corporation of America had knowledge of the subject matter of Van Saun at the time of the preparation of the Poole application for patent?

Mr. Boettcher: Oh, I object to this.

The Court: Sustained. [175]

Q. (By Mr. Russell): Was the patent of Van Saun considered by the Patent Office Examiner during the Poole application for patent?

A. No, it was not.

Q. What class was the Van Saun patent classified in the Patent Office?

(Testimony of Robert C. Comstock.)

A. That was Class 229, subclass 5.5.

Q. How does that compare with the class of the Poole patent?

A. I believe that is the identical class. Yes, it is.

Q. In your opinion is the Van Saun patent pertinent prior art as against the Poole patent in suit?

A. Very definitely pertinent.

Q. In your opinion you believe there had been inadvertence, error or mistake on the part of the Patent Office in failing to cite the Van Saun patent against the Poole?

Mr. Boettcher: I object.

The Court: Sustained.

Q. (By Mr. Russell): What was the feature shown in the Van Saun patent—now, not the file wrapper referred to, Mr. Comstock, but the patent itself in Defendant's Exhibit B—what feature is shown by Van Saun that was not shown in any of the patents cited by the Examiner during prosecution of the Poole application for patent?

A. Well, that is the concept of the cut-away portion [176] or the enlarged recess to accommodate a lap joint. That was shown in Van Saun. It was not shown in any of the references which were cited by the Examiner.

Q. You consider Van Saun as more pertinent than any of the other references used by the Patent Office against the Poole patent?

A. Very definitely. Much more pertinent than any of them before the Examiner.

(Testimony of Robert C. Comstock.)

Q. Let's refer to the last patent, the patent to Hill in Defendant's Exhibit B.

Mr. Boettcher: I would like to have the record show I have a standing objection to the consideration of that as prior art.

Q. (By Mr. Russell): Do you find any resemblance between the patent to Hill and the patent in suit, Mr. Comstock?

A. Yes. The Hill shows a square container, the identical shape of the Poole patent, and the title of the patent is "Plastic Cover For Waxed Paper Containers." So you have the same combination of the plastic cover and the wax paper container that you have in the Poole patent.

In fact, the Hill patent refers to a transparent plastic material preferably polystyrene. And I believe the Poole patent—yes, Poole also states that his cover is formed preferably of a transparent plastic such as polystyrene.

With regard to the relationship between the top of the [177] container and the container itself, that is, the cover, we have a recess which is downwardly directed and which is tapering, and there is a wedging or compressing action when the top of the container fits into the recess.

There is no lap joint structure in the Hill patent. That is the only difference between the structures shown in Hill and that shown in the Poole patent.

The Court: Before you go on, do I understand correctly that the standing objection to this Hill patent and the questions relating to it is based upon

(Testimony of Robert C. Comstock.)

the fact that the letters patent were issued on December 30, 1952?

Mr. Boettcher: Yes, while our application was pending, while the Poole application was pending.

The Court: All right.

Q. (By Mr. Russell): Referring to all of the patents, Mr. Comstock, in Defendant's Exhibit B, do you find a complete disclosure of the Poole structure in any one of the patents? A. No, I do not.

Q. Now, referring to Claims 1 and 2, for example, of the Poole patent, do you find any complete disclosure in any two of the patents in Defendant's Exhibit B that would be described generally—let's say specifically by the structures claimed in Claims 1 and 2 of the Poole patent?

Mr. Boettcher: You mean two taken together?

Mr. Russell: 1 or 2. [178]

The Witness: Yes, I would say the structure in 1 and 2 or in both of those claims would be found by combining any of a number of pairs of references. For example, combining the Hill patent with Van Saun, since Hill shows the wax paper container and the plastic cover and the downwardly directed recess, and Van Saun shows the cut-away portion or enlargement to receive the lap joint.

Likewise, you could combine Hill with Moore, since Moore also shows a recess which is enlarged to receive a lap joint.

You could also combine either the Van Saun or the Moore patents, which show the recesses, with the Drake patent, for example, which shows the

(Testimony of Robert C. Comstock.)

tapering recess and the compression of the cover. Or with Rutkowski, that is, you could combine Drake with Rutkowski, you could combine Drake with Moore or you could combine Rutkowski with Van Saun or Rutkowski with Moore, and you would find all of the structures and elements set forth in Claims 1 and 2 of the Poole patent.

Q. (By Mr. Russell): It is your opinion, Mr. Comstock, that the combination of any of the six combinations you just referred to would be obvious to anyone skilled in the art? A. Yes.

Q. Is there any substantial difference between Claims 1 and 2 of Poole and the remaining claims of the Poole patent?

A. Well, the remaining claims, some of them recite the fact that the cover is plastic and some of them refer to [179] it being square in shape. And they also define the location of the lap joint and the recesses being in a corner of the cover.

There are only these minor differences between the remaining claims and Claims 1 and 2.

Q. Do I understand, then, if Claims 1 and 2 were invalid, or, let's say in the public domain, that there would not be any patentable novelty in any of the remaining claims?

Mr. Boettcher: I object.

The Court: Sustained.

Q. (By Mr. Russell): Let us refer, Mr. Comstock, to the plaintiff's commercial embodiment, the carton, Plaintiff's Exhibit 20, and the lid therefor, Plaintiff's Exhibit 21. You have seen structures of

(Testimony of Robert C. Comstock.)

that type before?       A. Yes, I have.

Q. In your opinion, Mr. Comstock, do any of the claims of the Poole patent in suit read upon the structure of the two components now before you?       A. In my opinion they do not.

Q. Are you familiar with the concept of mechanical skill in connection with inventions?

A. Yes, I am.

Mr. Boettcher: That is a big order. I object to that question. The concepts——

The Court: It is a preliminary question. But I think [180] the one that it is preliminary to is probably objectionable, so the immediate objection is overruled.

Q. (By Mr. Russell): In your opinion, Mr. Comstock, do you find anything more than a mere mechanical skill in widening the groove of a cover to accommodate a lap joint?

Mr. Boettcher: I object to it.

The Court: Sustained. That is invading the province of the court. It is the ultimate fact in issue. He can't express an opinion.

Q. (By Mr. Russell): Referring to the patent in suit, Mr. Comstock, considering all the elements claimed, does the container do anything different than the containers disclosed in the prior art you referred to?       A. No.

Q. Does the groove in the lid do anything different than the prior art disclosures?

A. No, it doesn't.

Q. Does the widening of the groove do anything

(Testimony of Robert C. Comstock.)

different than it did before, as illustrated in, for example, the patent to Moore of Defendant's B and the patent to Van Saun?      A. No, it does not.

Q. Each of the elements perform the same function as they did in the prior art?

Mr. Boettcher: I object to that.

The Court: Sustained. [181]

Mr. Russell: You may cross-examine, Mr. Boettcher.

Mr. Boettcher: I don't think I can possibly complete the cross examination of this witness in what I would regard as a reasonable time to keep the court.

The Court: Well, what do you want to do about it?

Mr. Boettcher: May I discuss it with my colleagues?

The Court: Yes.

Mr. Boettcher: Would it be fair for me to ask how long the court would care to sit? My idea was to get through by 5:00, and I think that is pretty short time.

The Court: That was my idea, too. However, I can sit a little longer. I can stay a little later, and if it is necessary I can convene tomorrow. I had hoped to spray my roses, but I suppose they can take a few more aphids.

Mr. Boettcher: I dislike to interfere with that pleasure. Supposing I go ahead and see where I—

The Court: Go ahead and see what you can do. Perhaps by 5:30 you can finish.

(Testimony of Robert C. Comstock.)

Cross Examination

Q. (By Mr. Boettcher): Look at the Van Saun patent, 2,392,959. A. Yes, I have it.

Q. Now, you tell me where the groove is that you regard as corresponding to the peripheral recess in the Pool patent in suit. [182]

A. The groove would be the space between the second disc, I believe he calls it, and the wall of the lid. I think that is 29; I will have to check that.

The disc is 25, and one edge of that would be one side of your recess and the other——

Q. Now, looking at Figure 1, you regard the disc, that the space, the angular space between the disc 25 and the internal wall of the downwardly extending portion of the cover as being the groove, do you? A. That is right.

Q. Now, what is that disc for, that disc 25?

A. It is for that purpose, as I understand it. It is for the purpose of providing a fit between the cover and the container.

Q. You say it is for the purpose of making a groove? A. Yes.

Q. Suppose I were to suggest it is for the purpose of reinforcing the top, would that be right or wrong?

Mr. Russell: I believe that is objectionable, your Honor. It is argumentative.

The Court: Overruled.

The Witness: If you fasten the disc, it certainly would reinforce. I don't see anything in the patent



(Testimony of Robert C. Comstock.)

now, glancing at it rapidly, that states that it is for the purpose of reinforcement. [183]

The Court: Don't we have to take what the patent teaches?

Mr. Boettcher: Pardon me?

The Court: Don't we have to take what the patent teaches?

Mr. Boettcher: Yes. And I am taking what the patent teaches.

The Court: It appeared from the question you were probing into what this man's interpretation is.

Q. (By Mr. Boettcher): Well, what good does the groove do, Mr. Comstock?

A. Well, it provides the space there to accommodate the top of the container.

Q. Well, you mean that the disc is put into that cover, in order to form a space?

A. That is right.

Q. Well, so as to make clear the line of my cross examination, my idea is that the disc is put there for the purposes of the disc, and the groove is something that results from that and with no purpose at all, except to make room for the circular wall that is coming up there. Isn't that right?

A. No.

Mr. Russell: I will object, your Honor please. Although this is very informative, I believe the patent will speak for itself in that regard. [184]

The Court: The objection is sustained.

Q. (By Mr. Boettcher): Does that reference character 30 indicate the groove?

(Testimony of Robert C. Comstock.)

A. Yes, it does. 30 is defined as a recess.

Q. All right. Now, the wall, the circular wall that extends into the groove doesn't touch the disc at all, does it?

A. As shown in Figure 1 it does not touch.

Q. Does it show anywhere?

A. No, but the patent states, not with regard to that, but with regard to one of the other recesses, that the recess is shown slightly larger than it actually would be for the purpose of clarity, so I assume that would apply equally well to Figure 1.

Q. How deep is that groove?

A. It is rather shallow.

Q. The groove is as deep as the disc is thick, and that is all? That is correct, isn't it?

A. That is all, that is right.

Q. Is there any possible wedging action there caused by the circumference of the disc?

A. Well, yes, the specification states on page 2 in the second column, about lines 29 and 30, in referring to the disc action at the bottom of the container:

"the lower edge of the body member is intended to fit [185] rather snugly."

Since it refers to that structure as being similar to that at the top, I assume that the tight fit was meant at the top as well.

Q. Well, that doesn't mean a wedging action, does it? That doesn't mean any kind of a compression of the wall, the circular wall, does it?

A. He states "fit rather snugly."

(Testimony of Robert C. Comstock.)

Q. Now, refer to Claim 9 of the Van Saun patent to which you referred. Is there any possibility of that Claim 9 apply to the disclosure of the Poole patent in suit?

A. If you mean a question of infringement, there is no question of infringement. Poole would not infringe it if—I am not sure what you mean by “applying to the disclosure.”

Q. Your point is that Mr. Van Saun was trying to claim the making of a space for the overlap? He——

Mr. Russell: Now, your Honor,—Excuse me, counsel.

Q. (By Mr. Boettcher): He was doing that only in respect of Claim 9. It is a dependent claim on Claim 9, isn't it?

A. That is right. Claim 13 is dependent on Claim 9.

Q. Claim 9 wouldn't have anything to do with the Poole patent, would it?

A. Oh, I wouldn't say that. There are similarities, but there would be—the structure that is set forth there, a great deal of the structure that is set forth in Claim 9 is [186] not found in Poole.

Q. Let's look at the Moore patent, 2,381,508.

You spoke about a peripheral groove there, did you not? A. Yes.

Q. Where is it?

A. That would extend between the two walls again. I will have to check those numbers. I believe that 27 is one of them.

(Testimony of Robert C. Comstock.)

You see, the flange is 27, and 28 are the outer flanges. I think 25 and 26 are the inner flanges. So that the groove would be the part between those flanges.

Q. Well, that is not a peripheral groove that you describe there, is it? It is two parallel grooves at opposite ends of a cross piece, isn't that right?

A. Well, when the cross pieces are put together here you have a cover with a groove extending around the periphery of it.

Q. In other words, you have two sides that are on one cross piece and the other two sides are on the other cross piece?

A. Before assembly, that is correct.

Q. So it isn't a one-piece affair at all, is it?

A. That is correct.

Q. What was it you said about the first claim of the Poole patent not applying to Exhibit 20 and 21? [187]

A. Yes, I said that in my opinion Claim 1 of the Poole patent did not cover the structure shown in Exhibits 20 and 21.

Q. You said the same about Claim 2, didn't you?

A. That is correct.

Q. How about Claim 3?

A. Yes, the same answer.

Q. What is there about Claim 3 that does not apply to this combination of Plaintiff's Exhibits 20 and 21?

A. Well, one thing, the Claim 3 states:  
"said recess being of uniform width for the major

(Testimony of Robert C. Comstock.)

portion of its extent and of increased width at a corner of said corner to accommodate said lap joint."

Now, here we have one, a recess which is not of uniform width because there are four points at which it has increased width. So it is not of uniform width, with the exception of a corner as described in the claim.

Q. Well, it is of uniform width except for the four corners, isn't it?

A. Except for four corners, yes.

Q. Right. And the four corners includes one corner, doesn't it? I just want to get your idea, of how you read these claims.

A. Well, when you—I think you have to construe the claims in the light of the specification and drawing, and when the specification and drawing show a structure in which you [188] have a lap joint and a recess at one corner, then that claim—you can't say that four corners includes one corner, because you have changed the structure considerably.

Q. You are construing the claim, is that right?

A. In the light of the specification and claims, yes, it has to be.

Q. It is in the nature of a legal opinion, is that right?

A. If you want to call it that. I think any answer I would give would necessarily be a legal opinion.

(Testimony of Robert C. Comstock.)

Q. Have you considered Claims 4, 5 and 6 in the same way as you just explained about Claim 3?

A. Yes, the answer would be the same. The difference would be the same.

Q. Refer now, if you will, please, to that Rutkowski patent, 2,155,002. A. Yes.

Q. In that body, with reference to character 1, that body is made up of thin paper, wrapped, isn't that right?

A. It states that the body is in the nature of a paper tube. I believe it is a matter of past experience that I have seen tubes formed wrapped. I don't see anything in here right immediately that states that it is wrapped.

Q. In any event, there is no lap joint there?

A. There is no lap joint, that is right. [189]

Mr. Bottecher: I am pleased to say that is all the cross examination I have.

The Court: All right: Judge Harrison, who sits in the next courtroom, doesn't like to have these patent attorneys called as experts and you have a hard time getting one on, because he says it is only an advocate making a legal argument. I think a sequel to that view, which might be said to be well taken, would be that attorneys in making arguments may make the same kind of comments that are made by witnesses in the position of the witness on the stand here.

From my viewpoint here, as a trier of fact, you just can't try a patent case without this kind of thing. But I am inviting you to treat it as fully

in your brief as your opponent has treated it by expert testimony.

Mr. Boettcher: Thank you very much.

Mr. Russell: That is all, Mr. Comstock.

(Witness excused.)

Mr. Boettcher: The defendant rests?

Mr. Russell: The defendant rests, your Honor.

Mr. Boettcher: Plaintiff has no rebuttal.

The Court: What is your pleasure about briefing the case?

Mr. Russell: Let us have Mr. Boettcher's pleasure.

You are leaving tomorrow for Chicago, I presume?

Mr. Boettcher: In the present circumstances, yes, assuming we can postpone the oral argument.

The Court: Oh, yes, you can postpone it until after briefs. I do hope you will put in some briefs. I would like to be briefed a bit upon this question of the Van Saun file wrapper and file history there.

My present feeling is that we will probably find that, according to the law, it is admissible, but I don't know that.

I have rather provisionally admitted it, and I am not going to look at it until I am sure about it.

Mr. Russell: We shall treat it rather well, your Honor.

Mr. Boettcher: We will struggle with it. And also, I think that it would be true also of the Hill patent. I have an axe to grind as to that one.

The Court: Yes. I think the questions regard-

ing the Hill patent as prior art are very serious. In fact, there are so many very serious questions in the case, I am hopeful something will happen I don't have to decide it.

Mr. Boettcher: We prepared briefs before opposing each other, and we can do it again.

Mr. Russell: Very well. What is your pleasure, Mr. Boettcher, in the submission of briefs?

Mr. Boettcher: Let me say this: I like to prepare a brief after the transcript is written up. I mean, a great deal of time is saved.

The Court: Then we will have the time for briefs begin to run upon the reporter advising me that the transcript has [191] been sent to you.

Mr. Boettcher: That is fine. And then, say, 20 days for the plaintiff's opening brief?

The Court: Let's make it 30. 30 days after the delivery of transcript.

I suppose you want it delivered to your local counsel, or do you want it mailed to you?

Mr. Boettcher: We can arrange that. When it is mailed it can be assumed to be delivered to me.

The Court: All right. 30 days thereafter for your opening brief.

How much time do you want then to reply?

Mr. Russell: I would like to have the opportunity of the 30 days as well, your Honor, because I believe the amount of research and briefing on the particular Van Saun issue and the Hill issue will perhaps be greater than the rest of the brief.

The Court: All right. 30 days then from the



mailing date to you of the plaintiff's brief for your reply brief.

Mr. Russell: Very well, sir.

The Court: And I should think after all that time that the reply brief, if any, would come in rather shortly.

Mr. Boettcher: Right.

The Court: How long do you want?

Mr. Boettcher: 15 days.

The Court: All right. So ordered. Then after they are [192] in, you can correspond with each other and find an agreeable date for oral argument, or determine whether you wish to submit the matter entirely on briefs and transcript.

Mr. Russell: Very well, your Honor.

Mr. Boettcher: I think that will be very satisfactory. We can do that. I can communicate with Mr. Brown, and he can see you and make any arrangements that meet with the mutual convenience.

Mr. Russell: Very well. What is your suggestion, your Honor, as to the means for having oral argument before your Honor?

The Court: It depends upon how much time you want. If you are going to argue for upwards of an hour apiece, I would like to set the oral argument for some Friday. Then if we are in mid-trial, and a long trial, we will just recess that trial for the day and hear you on a Friday. If you are only going to talk a few minutes we can have it on a Monday afternoon, that being motion day.

Mr. Russell: Very well, sir.

Mr. Boettcher: That can be arranged by Mr. Russell and Mr. Brown with your Honor.

The Court: Yes.

Mr. Russell: Fine. Thank you kindly, sir.

The Court: When you have come to some understanding and have some alternate dates in mind and know what you plan with [193] respect to time, Mr. Russell and your correspondent here can come in and see me and we will arrange a time.

The cause will then stand submitted.

Thank you. It has been a pleasant trial.

Mr. Russell: Thank you, your Honor.

Mr. Boettcher: I desire to thank your Honor for the attentive hearing.

The Court: I am sorry you had to wait so long to get to it.

Mr. Boettcher: It wasn't unpleasant. It was very pleasant.

Mr. Russell: It is my understanding Mr. Boettcher desires to return to Chicago.

The Court: A pleasant journey back.

Mr. Boettcher: Thank you so much.

The Court: Adjourned.

(Whereupon, at 5:00 o'clock p.m., Friday, May 4, 1956, the case was submitted.)

[Endorsed]: Filed June 20, 1956. [194]

[Endorsed]: No. 15433. United States Court of Appeals for the Ninth Circuit. Container Corporation of America, a corporation, Appellant, vs. M. C. S. Corporation, Appellee. Transcript of Record. Appeal from the United States District Court for the Southern District of California, Central Division.

Filed: February 11, 1957.

/s/ PAUL P. O'BRIEN,

Clerk of the United States Court of Appeals for the Ninth Circuit.

In The United States Court of Appeals for the  
Ninth Circuit

No. 15433

CONTAINER CORPORATION OF AMERICA,  
Plaintiff-Appellant,

v.

M C S CORPORATION, Defendant-Appellee.

NOTICE OF WITHDRAWAL AS ATTORNEYS  
FOR THE DEFENDANT-APPELLEE

Please take notice that Harris, Kiech, Foster & Harris, Donald C. Russell, Esq., Warren L. Kern, Esq., and Walton Eugene Tinsley, Esq., hereby withdraw as attorneys for M C S Corporation, Defendant-Appellee in the above action.

Dated: January 31, 1957.

HARRIS, KIECH, FOSTER AND  
HARRIS,  
DONALD C. RUSSELL,  
WARREN L. KERN,  
WALTON EUGENE TINSLEY,

/s/ By WARREN L. KERN,  
Attorneys for Defendant-Appellee.

Affidavit of Service by Mail Attached.

[Endorsed]: Filed February 1, 1957. Paul P. O'Brien, Clerk.

[Title of Court of Appeals and Cause.]

STATEMENT OF POINTS AND DESIGNA-  
TION OF RECORD TO BE PRINTED

Appellant hereby adopts its Statement of Points, filed in the District Court, dated January 2, 1957, appearing on page 300 of the typed record, as its Statement of Points under the provisions of Rule 17(6) of the Rules of the Court of Appeals.

Appellant hereby adopts its Designation of Contents of Record of Appeal, filed in the District Court, dated January 2, 1957, appearing on page 302 of the typed record, excluding the exhibits, items 10 and 11, as its designation of the record to be printed on appeal, as provided for by Rule 17(6) of the Rules of the Court of Appeals.

/s/ J. CALVIN BROWN,  
Attorney for Plaintiff-Appellant.

Affidavit of Service by Mail Attached.

[Endorsed]: Filed February 20, 1957. Paul P. O'Brien, Clerk.



---

---

In the  
**United States Court of Appeals**  
For the Ninth Circuit

---

No. 15433

---

---

CONTAINER CORPORATION OF  
AMERICA,  
*Plaintiff-Appellant,*  
*vs.*  
MCS CORPORATION,  
*Defendant-Appellee.*

Appeal from the United  
States District Court for  
the Southern District of  
California, Central Divi-  
sion.

Honorable  
Ernest A. Tolin,  
Judge.

---

---

**BRIEF FOR APPELLANT.**

---

BROWN, JACKSON, BOETTCHER & DIENNER,  
ARTHUR H. BOETTCHER,  
53 W. Jackson Blvd.,  
Chicago 4, Illinois,  
*Counsel for Appellant.*

J. CALVIN BROWN,  
704 S. Spring Street,  
Los Angeles 14, California,  
*Attorney for Appellant.*

FILED

MAY - 3 1957





## SUBJECT INDEX.

---

	PAGE
Statement of Pleadings and Facts re Jurisdiction....	2
Statement of the Case.....	3-20
In General .....	3
The Proceedings Below.....	4-5
The Invention, the Patent Application, and the Patent .....	5-14
The Infringement by Defendant.....	14-18
The Question Involved and the Manner in Which It Is Raised.....	18-20
Specification of Errors Relied Upon.....	20
Argument .....	21-36
Conclusion .....	36

### TABLE OF CASES AND STATUTES CITED.

#### *Cases.*

American Graphophone Co. v. Emerson Phonograph Co., 255 F. 574.....	25
Bates v. Coe, 98 U. S. 31.....	30
Gray Telephone Pay Station Co. v. Baird Mfg. Co., 174 F. 417.....	25
Kurtz et al. v. Bell Hat Lining Co., Inc., 280 Fed. Rep. 277 .....	34
McClain v. Ortmyer, 141 U. S. 419.....	33
New York Scaffolding Co. v. Whitney, 224 F. 452....	25
Old Town Ribbon & Carbon Co. v. Columbia R. & C. Mfg. Co., 159 F. (2d) 379.....	24
Parks v. Booth, 102 U. S. 96.....	31
Ric-Wil Co. v. E. B. Kaiser Co., 179 F. (2d) 401....	35

Robertson Rock Bit Co. v. Hughes Tool Co., 176 F. (2d) 783 .....	32
Ry-Lock Company v. Sears, Roebuck & Co., 227 F. (2d) 615 (1955).....	3
H. D. Smith & Co. v. Peck, Stow & Wilcox Co., 262 Fed. Rep. 415.....	34
In re Spencer, 47 F. (2d) 806.....	24
Stebler v. Riverside Heights Orange Growers' Ass'n., 205 F. 735.....	32
Steiner Sales Co. v. Schwartz Sales Co., 98 F. (2d) 999 .....	34
Town et al. v. Willis, 85 F. Supp. 483.....	35
Town et al. v. Willis, 182 Fed. 2nd 892.....	35
Williams Mfg. Co. v. United Shoe Mach. Corp., 121 F. (2d) 273.....	31

*Statutes.*

United States Code, Title 28, Section 1291.....	2
United States Code, Title 28, Section 1338.....	2
United States Code, Title 28, Section 1400(b).....	2
United States Code, Title 28, Section 2201.....	2
United States Code, Title 35, Section 102.....	23
United States Code, Title 35, Section 103.....	19
United States Code, Title 35, Section 271(b) and (c) ..	18
United States Code, Title 35, Section 282.....	4

In the  
**United States Court of Appeals**  
For the Ninth Circuit

---

**No. 15433**

**CONTAINER CORPORATION OF  
AMERICA,**  
*Plaintiff-Appellant,*

*vs.*

**MCS CORPORATION,**  
*Defendant-Appellee.*

Appeal from the United  
States District Court for  
the Southern District of  
California, Central Divi-  
sion.

---

Honorable  
**Ernest A. Tolin,**  
Judge.

---

**BRIEF FOR APPELLANT.**

---

This is an appeal by plaintiff from Judgment of the Dis-  
trict Court holding plaintiff's patent in suit invalid, dis-  
missing its Complaint, and sustaining a Counterclaim by  
defendant, with costs to defendant.

STATEMENT OF PLEADINGS AND FACTS RE  
JURISDICTION.

---

The Complaint in this case, filed February 25, 1954, is for infringement of plaintiff's United States Letters Patent No. 2,638,261, issued to it May 12, 1953, as assignee of William J. Poole (Tr.\* 3-4, Pl. Ex.\*\* 3), under Title 35, United States Code, and the District Court had original jurisdiction under Title 28, United States Code, Sec. 1338.

Defendant is a California corporation (Pl. Ex. 2, Tr. 41) with its place of business at 1120 North La Brea Avenue, Los Angeles, California, there conducting the business complained of under adopted names "Ree-Seal" and "Ree Seal Company" (Tr. 18, 43-44, Pl. Ex. 10, 11, 12). The United States District Court, Southern District of California, Central Division has jurisdiction of defendant under Title 28, United States Code, Section 1400 (b).

Jurisdiction, in both respects above, is admitted by defendant's Answer (Tr. 5).

The said Counterclaim by defendant (Tr. 11-12, 13) merely puts its Answer in the form of prayer for affirmative relief; it raises no further issue. It is alleged to arise under Section 2201 of Title 28 of the United States Code (Tr. 12), but plaintiff, in its Reply to Counterclaim, "denies any need for the said counterclaim because the issues presented by it are already joined by the Complaint and Answer" (Tr. 14).

This Court of Appeals has jurisdiction to review the judgment referred to, under 28, United States Code, 1291.

---

\* Printed Transcript of Record.

\*\* Plaintiff's Exhibit.

STATEMENT OF THE CASE.

---

We divide this portion of this brief into sub-headed sections, concluding with statements of the question involved and the manner in which it is raised.

**In General.**

Plaintiff is a Delaware Corporation (Pl. Ex. 1, Tr. 41) having its general office in Chicago, and its business is the manufacture and sale of numerous types of paperboard containers for various specific purposes (Tr. 49 *et seq.*).

The subject matter of the patent in suit is a "Frozen Food Carton with Plastic Lid", the application for the patent having been filed in the Patent Office on May 10, 1948 (Pl. Ex. 5). The development of the patented package, and the manufacture and sale of such packages by plaintiff, will be set forth presently.

Plaintiff's cause of action lies in defendant's manufacture (or causing to be manufactured) and sale of lids like plaintiff's, for use with the lower portions of used conventional waxed paper-board milk containers which the housewife would ordinarily discard.

Defendant began manufacture and sale of such bids in March of 1951 (Tr. 23), but they did not come to the attention of plaintiff until shortly before November 2, 1953, when plaintiff sent a letter to Ree-Seal (Pl. Ex. 13, Tr. 45) giving notice of infringement of the patent in suit, said letter having been received by defendant on or about November 5, 1953 (Tr. 18, 43-44).

### The Proceedings Below.

As previously stated, the Complaint was filed in February, 1954, followed by defendant's Answer and Counterclaim (Tr. 5-13) and plaintiff's Reply to Counterclaim (Tr. 14-15) in April.

In June of 1954, defendant moved for summary judgment, alleging invalidity of the patent for lack of invention and lack of invention over the prior art.\* That proceeding was briefed, heard, taken under advisement, and the motion denied on September 27, 1954.

In due course the case was set for trial.

In October 1955, under Title 35, United States Code, Sec. 282, defendant gave notice of seven patents upon which it would rely at the trial; also, that it would rely on testimony of William J. Poole (inventor, patent in suit) (Tr. 15-16).

On March 28, 1956, plaintiff served and filed certain Requests for Admissions of Fact (Pl. Ex. 7, Tr. 16-19, 43) and certain Interrogatories (Pl. Ex. 14, Tr. 19-21, 45) under Rules 36 and 33, respectively, of the Federal Rules of Civil Procedure. The Requests for Admissions of Fact were not answered by defendant, leaving it, under the Rule, that the facts stated stand admitted (Tr. 43-44); defendant's answers to the interrogatories are in evidence as Plaintiff's Exhibit 15 (Tr. 22-24, 46).

Memoranda prior to trial were duly filed by the parties, and trial was had May 3-4, 1956 (Tr. 39-192). Subsequent to trial, defendant submitted its Exhibits H and I, proffered during trial (Tr. 25-26).

Times were set for briefs, and briefs were filed, Brief

---

\* We assume that it is not inappropriate for us to mention this, though not part of the printed Transcript of Record on Appeal; it is in the original Transcript of Record on Appeal, listed by the Clerk (Tr. 37-39), and we mention it so as not to fail to do so.

for Plaintiff, Closing Brief for Defendant, and Reply Brief for Plaintiff. Oral Argument was on November 5, 1956.

On November 7, 1956, the Court below handed down its Notice of Decision, finding the subject matter of the patent in suit "wanting in invention" (Tr. 26-28). This was followed by Findings of Fact, Conclusions of Law, and Judgment entered November 20, 1956 (Tr. 28-31), the Judgment, as stated above, holding the patent in suit invalid, dismissing the Complaint, and sustaining defendant's Counterclaim, with costs to defendant (Tr. 30-31).

Plaintiff filed its Notice of Appeal December 17, 1956 (Tr. 31); and its Statement of Points January 2, 1957.

### **The Invention, the Patent Application, and the Patent.**

What follows under this and the next sub-heading is an abstract of the facts, from the Transcript of Record and the exhibits.

In early 1947, the inventor, Mr. Poole (Tr. 66) thought to provide a new and improved package in which to freeze and cold-store foods, prepared foods such as fruits and vegetables, and particularly foods which are packed by the housewife and frozen and stored either in her own deep freezer or cold compartment of her kitchen refrigerator, or at a so-called locker plant (Tr. 56 *et seq.*).

He was originally employed by the plaintiff corporation on May 1, 1940, started with a production training course there, and was shortly assigned to its package development laboratory on experimental work on frozen food packages; there he remained until April 1, 1942, when he left to enter the Marine Corps, and he returned to the company in November, 1945, to take charge of sales and development in its frozen food package department or division on January 1, 1946 (Tr. 46-49).

He was consequently familiar with the practical art, with

the frozen-food packages that the market offered, of both plaintiff and its competitors, with freezers and locker plants, and with the growing practice domestically of preparing and packaging foods for freezing (Tr. 49-55).

This, when, in early 1947, he essayed a new and improved package for the purpose, as above stated.

At that time, plaintiff was manufacturing and selling the type of frozen food container referred to by Mr. Poole on Pages 49, 50-52 of the Transcript, a rectangular paper-board container comprising four sides, a bottom, and a top with a circular opening in it, this opening being closed by a round metal plug inserted therein. Mr. Poole's description of that antecedent container was facilitated by reference to a metal can (Pl. Ex. 15-A) (Tr. 50-52, 54).

Mr. Poole's first step was to determine upon a full-open-top rectangular container body, made from a single paper-board blank cut to shape and scored for folding and glued to completion, exemplified by Plaintiff's Exhibit 16, which was "one of the initial experimental packages that was made in early 1947" (Tr. 57-59). The purpose of the "full open top" was to facilitate the filling of the carton, and, more important, the removal of the contents (Tr. 56-58), and other advantages thereof will be noted as we go along.

There was nothing new about this container body, *per se*, but the selection of this type is significant.

Then came the question of the lid, and firstly that of the material of which it was to be made. Experiments were made with paper-board, drawn or stamped metal, and molded materials such as plastic (Tr. 58). Paper-board, drawn or stamped sheet metal, and molded metal were discarded, and a polystyrene plastic, molded under heat and pressure was determined upon; this, because it could be molded to form, and for reasons of its stability through the temperature range in which it would be used, its transparency and its cost (Tr. 58-60).



The Crown Cork Specialty Corporation, of Decatur, Illinois, had been making the stamped metal closure plugs for the above-mentioned then-current Container frozen food cartons, and the matter of manufacture of the proposed plastic lids was taken up with Crown Cork's Chicago representative; and carton bodies like Plaintiff's Exhibit 16, and ideas and sketches as to how the lid should be made, were submitted to him, this still early in 1947 (Tr. 60-61).

The upshot of that was that Crown Cork's Chicago representative and Mr. Poole made a trip to Crown Cork at Decatur "to lay this problem before their engineering and production people," and they submitted "these samples and sketches to the people who would have to build the molds and live with the production problems involved" (Tr. 61).

Pursuant to understanding arrived at, Container received initial lid samples, in June of 1947 according to Mr. Poole's recollection, and placed an order for 3000 the following month (Tr. 62). These were made in a single-cavity sample-run mold (Tr. 64-65).

These 3000 lids were to go along with a like number of cartons such as Plaintiff's Exhibit 16, for distribution to selected locker plants for field test to ascertain consumer reaction (Tr. 62). According to the best of Mr. Poole's knowledge, this distribution began in August of 1947 (Tr. 62).

Mr. Poole testified (Tr. 63) that, naturally, upon receiving the lids at Container, they were inspected and checked, only to find a flaw in that "there had been no allowance made for the double thickness of board at the manufacturer's joint of the carton," *i. e.*, the "glue flap on one panel of the carton, which is glued down to the corresponding meeting panel at the other end of the blank,"—called "manufacturer's joint" because it is a joint necessarily there in the process of manufacture.

Mr. Poole stated (Tr. 63) that by using the lid in the manner that the ultimate consumer would use it, by placing it on the carton body and pressing it down, the closure would not be liquid-tight and, if enough pressure were exerted, the plastic would split or crack there.

He countered that by re-fashioning the lid to augment the recess width at that point, and consulted the Crown Cork Chicago representative to learn if the mold could be revised accordingly, and, upon report that that was feasible, a "production" mold, so revised was ordered (Tr. 64-65). A "production" mold is one with a plurality of cavities (Tr. 65).

That mold, to the best of Mr. Poole's knowledge, was ordered in September of 1947, and lids to be made from that mold were ordered in October or November of that year. One hundred thousand such lids were ordered and that number of complementary cartons were put into production at the Container plant at the same time (Tr. 65-66).

One hundred thousand was not regarded as a large number. As stated by Mr. Poole, the idea was to sell approximately 2000 units to each of fifty selected distributors, and "to use this as a complete field test, which was designed to either prove or disprove the merit of the package." These sales were in the early spring of 1948. The lid, Plaintiff's Exhibit 17, is one of the first samples off the production mold; Plaintiff's Exhibit 18 is the same as Plaintiff's Exhibit 17 with "patent-applied-for" marking added; these lids carried the arrow for indicating the position of the widened portion of the peripheral groove, for accommodating the manufacturer's joint of the carton (Tr. 66-69).

On May 10, 1948, the Poole patent application was filed, exactly illustrating and describing these cartons and lids. (We shall presently refer to the prosecution in the Patent Office.)

The said 100,000 units (carton and lid) were sold in 1948 (Tr. 69).

In 1949, approximately 13,500,000 such units were sold (Tr. 69-70).

In the latter part of 1949, a subsidiary modification (within the scope of the patent application) came into being. It is illustrated in Plaintiff's Exhibit 19, a print of a shop drawing dated October 27, 1949, and the modification lay in enlarging the peripheral groove or recess at all four corners of the lid, the enlargement taking a triangular shape instead of rectangular as previously (Tr. 68-69).

Plaintiff's Exhibit 20 and Exhibit 21 illustrate the new type carton and lid; in the former, the top of the glue flap of the manufacturer's joint is cut away at a 45-degree angle, and, in the latter, the receiving enlargement of the peripheral recess is correspondingly made triangular, thus being closed at the apex whether or not filled by the carton wall double thickness; the point is to make it unnecessary for the housewife, in applying the lid to the carton, to register a particular corner of the lid with a particular corner of carton, the result being the same in any of the four positions of the lid relative to the carton (Tr. 71-73).

Container began selling this new type in 1950, and, in that year, whether arrow type or new type, sold 11,000,000 units; 1951, 12,500,000, all new type; 1952, 16,600,000; 1953, 15,100,000 (Tr. 70).

The patent issued May 12, 1953, and plaintiff began patent-marking the carton element (printing) with its first production for 1954 sales; the lid element when new molds were in order (Tr. 71-72).

Thus, the history of the conception, development, reduction to practice, commercialization, and public acceptance of the invention at bar.

---

It is appropriate, now, to consider briefly the application for the patent in suit, referring to Plaintiff's Exhibit 5 (Tr. 42-43), the file wrapper and contents of the patent in suit, and Plaintiff's Exhibit 6 (Tr. 43), copies of the prior patent references cited by the Patent Office Examiner in the course of the prosecution.

The application illustrates and describes one of the one hundred thousand cartons and lids sold in the early part of 1948, exemplified by Plaintiff's Exhibits 16 and 17, and Plaintiff's Exhibit 5 reflects a normal prosecution, directed to the determination of allowable claims in view of the prior art.

The amendments to the specification were purely formal.

Fourteen claims were initially presented (May 10, 1948). On January 24, 1949, all of those claims were rejected, by the Examiner, on five prior art references. In reply, in July, the applicant cancelled all fourteen claims, and presented Claims 15 to 20, inclusive.

In his next Action, July 27, 1950, the Examiner stated that Claims 18 and 20 appeared to be allowable; but he rejected Claims 15, 16, 17 and 19 on three further references, including one now relied upon by defendant.

(Claims 18 and 20 became Claims 1 and 2, respectively, of the issued patent.)

In reply (January, 1951), the applicant amended the four rejected claims, and added two new claims, 21 and 22.

On October 22, 1951, the Examiner rejected Claims 15, 16, 17 and 19, as amended, on three further references, including another now relied upon by defendant, but stated that the two new claims, 21 and 22, appeared to be allowable.

(Claims 21 and 22 became Claims 3 and 4, respectively, of the issued patent.)



FROZEN FOOD CARTON WITH PLASTIC LID

Filed May 9, 1948

Fig. 1.

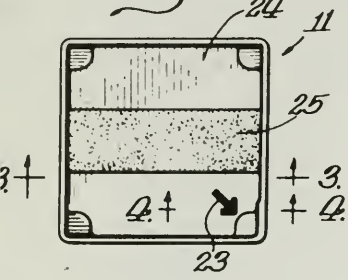

Fig. 3.

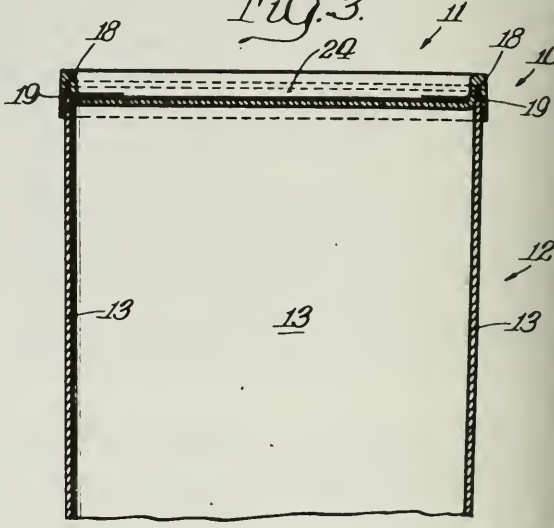

Fig. 2.

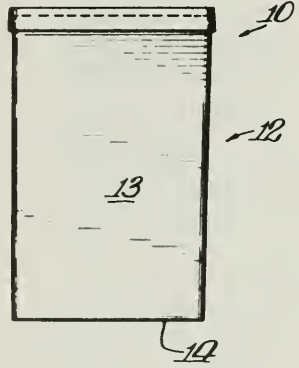

Fig. 4.

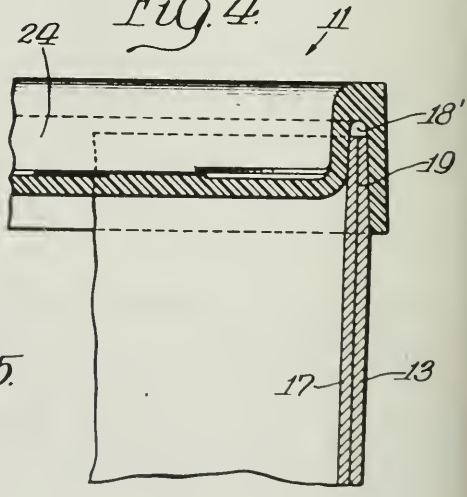
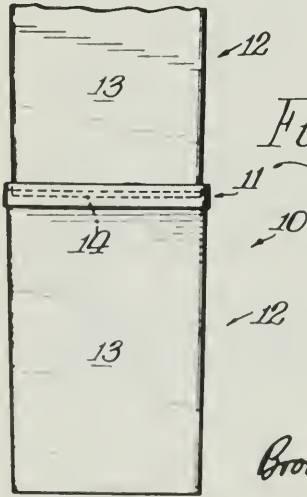

Fig. 5.



Inventor.  
William J. Poole

By  
Brown, Jackson, Boettcher & Diener  
Attys

In reply (February, 1952), the applicant amended Claims 15, 16 and 17 further, cancelled Claim 19, and added two new claims, 23 and 24.

On September 19, 1952, the Examiner stated that the two new claims, 23 and 24 appeared to be allowable, but he rejected Claims 15, 16 and 17, as further amended, on the same references, making that rejection final.

Whereupon, the applicant filed an appeal to the Board of Appeals in respect of rejected Claims 15, 16 and 17, and, in due course, filed the brief required in such proceeding.

On November 24, 1952, the Examiner handed down his Statement on the appeal, and, in due course thereafter, the appeal was set for hearing on October 8, 1953.

In March 1953, the applicant, deciding to forego the three claims in question, gave notice to the Patent Office accordingly by filing a cancellation of them, which, on March 30, 1953, resulted in an allowance of the application with its Claims 18, 20, 21, 22, 23 and 24.

Due payment of the final Government fee resulted in issue of the patent (Plaintiff's Exhibit 3) on May 12, 1953, with said claims, respectively renumbered 1, 2, 3, 4, 5 and 6.

---

A copy of the patent drawing is inserted here for reference and it will be seen that the various figures show a carton like Plaintiff's Exhibit 16 and a lid like Plaintiff's Exhibit 17 which is one of the first samples off the production mold from which the 100,000 run was made in the early spring of 1948 (see page 6, *supra*). (Referring to the circular markings at the four corners of Fig. 1, not referred to in the specification, they are the marks left by the sprues through which the fluid material is flowed into the mold.)

Consistently with the facts related by Mr. Poole, the patent points out the attributes of the carton *per se*—its construction from a single waxed paper-board blank with sidewall glue flap, its full-open top, its rectangular form, and its slight taper for nesting.

(The slight taper of the carton *per se* is not recited in any of the claims of the patent and is not involved against the accused assembly.)

Also, as in Mr. Poole's account, the patent points out the attributes of the lid,—its form with the under-side peripheral recess to receive and match the upper margin of the carton, the upward taper of its peripheral recess and the wedging action upon downward pressure, and the material of which it is made.

(Stacking of filled packages, as illustrated in Figure 5, is also made point of, but that entails slight taper of the carton *per se*, which, as above stated, is not involved here.)

As to the claims:

There are six claims. Claims 1 and 3 go to the combination of carton and lid, and Claims 2, 4, 5 and 6 go to the lid *per se*.

To exemplify the reading of the claims on the patent disclosure, we apply the first of each of these groups to the patent drawing by reference characters, as follows:

Claim 1:

A frozen food carton comprising, an open top paper-board body (12) having a lengthwise lap joint (17, Fig. 4) extending to its upper edge (19), and a plastic friction cover (11) having a downwardly opening peripheral recess (18, Fig. 3) tapering upwardly, said recess being of increased width (18', Fig. 4) for a portion of its length corresponding to said lap joint and of uniform width for the remainder of its length and



fitting tightly over the upper edge portion of the wall (13) of said body with the opposed surfaces of said recess contacting the inner and the outer surfaces of said wall for the major portion of the depth of said recess and compressing said wall between said opposed surfaces thereby providing a tight friction seal between said cover and said body.

Claim 2:

A reusable plastic cover (11) for a frozen food carton body having a lengthwise lap joint extending to its upper edge, said cover having a downwardly opening peripheral recess (18, Fig. 3) tapering upwardly, said recess being of increased width (18', Fig. 4) for a portion of its length corresponding to the lap joint of the carton body and of uniform width for the remainder of its length, for frictional engagement over the upper edge portion of the wall of the carton body.

Claim 3, the other claim to the combination of carton and lid, is like Claim 1, except that it requires the open-top paper-board body to be substantially rectangular in cross-section and the lap joint to be at a corner, and the lid to be correspondingly rectangular and to have the widened portion of its peripheral recess at a corner.

Claim 4, a lid claim, differs from Claim 2, in effect, as Claim 3 differs from Claim 1, *i. e.*, the lid is required to be substantially rectangular and to have the widened portion of its peripheral recess at a corner.

All first four claims require the lid to be of a plastic. Claim 5 is not restricted in that respect; in effect, it is like Claim 4, not limited in that respect, but, specifically directed to the rounded corners (see Fig. 1), which facilitate application to the carton.

Claim 6 is like Claim 4, except that it is not limited to a thin-walled peripherally-flanged construction, but would embrace a prismatic form.

All the units sold by plaintiff in 1948 and 1949 and into 1950 were, in all material respects, identical with the carton and lid assembly illustrated and described in the patent, and thus under all the claims of the patent.

Plaintiff's modified type, with the chamfered upper end of the carton glue-flap and the triangular enlargement of the peripheral recess at all four corners, represented by Plaintiff's Exhibits 20 and 21, which came into being in the latter part of 1949 and into vogue in 1950, come under at least Claims 3, 4, 5 and 6 of the patent.

### **The Infringement by Defendant.**

Plaintiff's cause of action lies in defendant's manufacture and sale of plastic lids identified, under "No. 1", in Plaintiff's requests for Admissions of Fact (Pl. Ex. 7, Tr. 16-17), which defendant did not answer and which, therefore, under the Rule, stand as admissions of fact (Tr. 43-44). The specimens are in evidence as Plaintiff's Exhibits 8 and 9 (Tr. 44).

Defendant's enterprise, here complained of, conducted under the adopted names "Ree-Seal" and "ReeSeal Company" (Pl. Ex. 7, No. 4, Tr. 18), was obviously born of the idea of selling lids like plaintiff's for use with used waxed paper-board milk containers which the housewife would ordinarily discard. This is evidenced by defendant's literature, Plaintiff's Exhibits 10 and 11 and defendant's advertisement in *Locker Management* for January, 1953, Plaintiff's Exhibit 12 (Tr. 44-45), all identified by Plaintiff's Exhibit 7, No. 2 and No. 3 (Tr. 17-18).

Defendant began the manufacture and sale of the accused lids in March of 1951 (Defendant's Answers, Pl. Ex. 15, to Plaintiff's Interrogatories 4 and 7, Pl. Ex. 14, see Tr. 23); but they did not come to the attention of plaintiff until shortly before November 2, 1953, when plaintiff sent



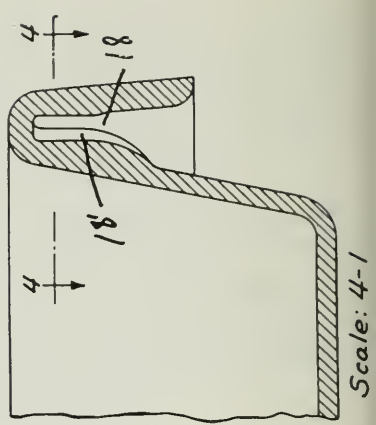
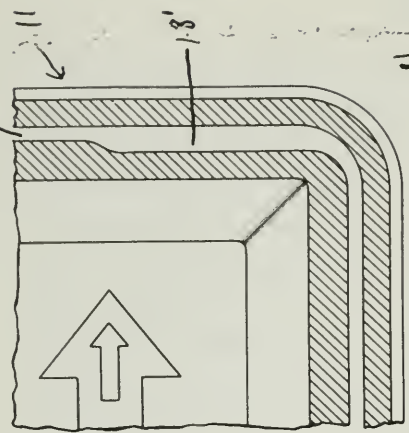
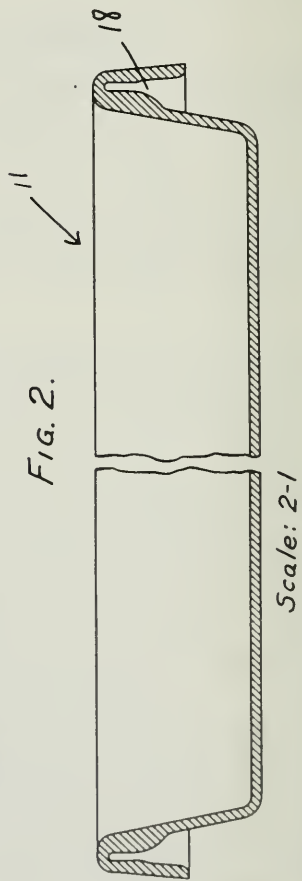
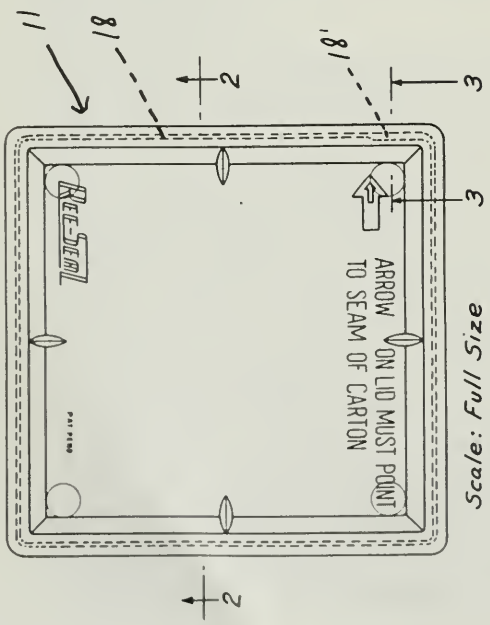

a letter to Ree-Seal (Pl. Ex. 13, Tr. 45), giving notice of infringement of the patent in suit, said letter having been received by defendant on or about November 5, 1953 (Pl. Ex. 7, No. 5, Tr. 18).

Defendant's lids are of two sizes, one to fit the horizontal cross-section of the half-gallon carton (top portion cut off), exemplified by Plaintiff's Exhibit 22B, and the other to fit the horizontal cross-section of the quart carton (top portion cut off).

Inserted here is a copy of Plaintiff's Exhibit 22A (See Tr. 122-123), which is a drawing of defendant's lid, Plaintiff's Exhibit 8. In the original, Fig. 1 is full size, but here the entire drawing is reduced to fit into this brief; the scales in the various figures are indicated.

That the structure is the same in all material respects as that of the lid of the patent in suit is self-evident.

The carton for which it is intended, Plaintiff's Exhibit 22B (Tr. 121) is the same as the carton of the patent, except for the slight taper of the latter which is optional in the patent claims.

The procedure instructed by defendant is set forth in its literature (Pl. Ex. 10, Tr. 17-18, 44-45—copy inserted here), Steps 1 and 2 of which set forth the initial preparation of the carton *per se* by cutting off the top portion of the milk carton; Step 3 is the rinsing of the carton and then allowing time to resume its condition as a waxed paper-board container (body minus top). Step 4 illustrates and describes the simple application of the lid to the carton, uniformly throughout assuming the widened portion of the peripheral recess to be aligned with the manufacturer's joint.

**SAVE** YOUR USED  
 • MILK CARTONS —  
 • THEY'RE VALUABLE

**REE-SEAL**  
LET THEM MAKE YOU

THE NEW VACUUM TIGHT LID — FITS ALL  
 STANDARD HALF GALLON MILK CARTONS,  
 MAKES THEM PERFECT FOR STORING OR  
 DEEP FREEZING ALL FOODS AND LIQUIDS.

• THE PERFECT  
 • SEAL FOR PAPER  
 • MILK CONTAINERS

**REE-SEAL**  
LET THEM MAKE YOU

AIR-TIGHT, WATER-TIGHT

Pat. Pending



**1**

Cut through 3 sides of carton scoring 4th side.



**2**

Turn carton over and cut scored side.

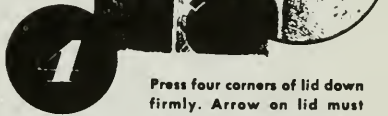

**1**

Press four corners of lid down firmly. Arrow on lid must point to seam on carton.



**5**

Store FROZEN FOODS in Freezer  
 Store DRIED FOODS in kitchen cabinets  
 Store LEFT OVER FOODS in refrigerator



**6**

Remove lid by raising one corner at a time.



**3**

Rinse carton in cool water. Allow carton to dry thoroughly before using.





Step 5 shows the storing of the packages in the freezer,—on their sides in this instance. Step 6 illustrates the opening of the package.

As we have above applied Claims 1 and 2 to the drawing of the patent in suit, we apply them here to this drawing of defendant's lid, using the same reference characters:

Claim 1:

A frozen food carton comprising, an open top paperboard body having a lengthwise lap joint extending to its upper edge and a plastic friction cover (11) having a downwardly opening peripheral recess (18) tapering upwardly, said recess being of increased width (18') for a portion of its length corresponding to said lap joint and of uniform width for the remainder of its length and fitting tightly over the upper edge portion of the wall of said body with the opposed surfaces of said recess contacting the inner and the outer surfaces of said wall for the major portion of the depth of said recess and compressing said wall between said opposed surfaces thereby providing a tight friction seal between said cover and said body.

Claim 2:

A reusable plastic cover (11) for a frozen food carton body having a lengthwise lap joint extending to its upper edge, said cover having a downwardly opening peripheral recess (18, Fig. 3) tapering upwardly, said recess being of increased width (18', Fig. 4) for a portion of its length corresponding to the lap joint of the carton body and of uniform width for the remainder of its length, for frictional engagement over the upper edge portion of the wall of the carton body.

As to Claims 3, 4, 5 and 6, the analysis on Pages 11 and 12, *supra*, show that they, too, apply to defendant's half-gallon lids and their intended cooperation with the half-gallon carton.

As to the quart size lid, Plaintiff's Exhibit 9, which is

adapted to the quart milk carton exemplified by Plaintiff's Exhibit 23A :

Here the carton structure (Pl. Ex. 23A) is somewhat different from the half-gallon size in that the lap-joint is in the middle of a side wall instead of at a corner, but the fundamental structure and the procedure is the same, as evidenced by Plaintiff's Exhibit 9 itself and defendant's literature, Plaintiff's Exhibit 11.

Since the enlargement of the peripheral recess in the lid, Plaintiff's Exhibit 9, is in the middle of a side wall instead of at a corner, and since Claims 3, 4, 5 and 6 require the lap-joint of the carton and/or the enlargement of the peripheral recess in the lid to be at a corner, they do not apply, but Claims 1 and 2 are not so limited and clearly apply as above pointed out in respect of the half-gallon size lid, Plaintiff's Exhibit 8.

Although defendant manufactures and sells only the lids, it is liable not only under the lid *per se* claims of the patent, but is equally liable under the carton and lid combination claims, this under Section 271(b) and (c) of United States Code, Title 35.

### **The Question Involved and the Manner in Which It Is Raised.**

Defendant, in its Answer, denied infringement, but it did not, at any time, adduce anything in support of that denial. In its brief below, on final hearing (Closing Brief for Defendant, listed in Certificate of Clerk, Tr. 37), defendant stated that there were "two primary issues", explaining that there can be no infringement of an invalid patent. That goes without saying, but it is not what is commonly understood by an issue of infringement; an issue of infringement is one of non-infringement, assuming the patent in suit to be valid in accordance with the presumption of law.

The issue here is validity of the patent.

There is no anticipation, nor any asserted; the subject matter of the patent stands as new.

*The question involved is whether its creation constituted an act of invention, or were the differences between it and the prior art "such that the subject matter as a whole would have been obvious at the time the invention was made to a person having ordinary skill in the art to which said subject matter pertains"* (Title 35, United States Code, Section 103).

That that is the single question involved is made clear by the Decision of the Court below (Tr. 26-28), which we shall refer to in the Argument to follow.

Now, as to the manner in which the question is raised:

Defendant adduced the following:

(1) Defendant's Exhibit B, containing copies of seven patents of which, as previously stated, defendant notified plaintiff under Title 35, United States Code, Sec. 282 (2);

(2) Defendant's Exhibit A, the file history of the Van Saun Patent No. 2,392,959, included in Defendant's Exhibit B.

(3) Defendant's Exhibit C and D, two argumentative sketches (Tr. 79-80).

(4) The adverse testimony of Mr. Poole, the inventor.

(5) The testimony of Mr. Robert C. Comstock, called by defendant as its expert.

(6) Defendant's Exhibit H, the File Wrapper and contents of the Hill Patent 2,623,685, included in Defendant's Exhibit B; and

(7) Defendant's Exhibit I, a certified copy of said Hill Patent 2,623,685, included in Defendant's Exhibit B.

The purpose of all this was to leave it that, when Mr. Poole essayed to produce a new package for a particular

use, and did so, he did none other than anyone of ordinary skill in the art would naturally have done at the time.

We treat this subject in the Argument to follow.

## SPECIFICATION OF ERRORS RELIED UPON.

---

In this brief, we proceed from the Statement of Points, filed in the District Court (Tr. 33-34), and adopted in this Court (Tr. 195), as follows:

1. The District Court, weighing the subject matter of the patent in suit for invention, erred in taking into account only the lap joint of the open-top carton and the widening of the under-side peripheral recess of the cover to accommodate the double thickness of the lap.

2. The District Court, weighing the subject matter of the patent in suit for invention, erred in not taking into account all the recitations in each of the claims of the patent in suit.

3. The District Court, weighing the subject matter of the patent in suit for invention, erred in not treating the same as a patentable combination of the elements as specified in the claims.

4. The District Court erred in finding the structure of the patent in suit wanting in invention and in finding that producing it involved no more than ordinary skill of the art.

5. The District Court erred in holding the patent in suit invalid and void, in dismissing the complaint, in sustaining defendant's counterclaim, and in awarding costs to defendant.

6. The District Court erred in not holding the patent in suit valid and infringed, in not granting the relief prayed for in the complaint, and in not dismissing the counterclaim, with costs to plaintiff.

ARGUMENT.

---

We first concern ourselves with Points 1, 2 and 3, which we repeat:

1. The District Court, weighing the subject matter of the patent in suit for invention, erred in taking into account only the lap joint of the open-top carton and the widening of the under-side peripheral recess of the cover to accommodate the double thickness of the lap.

2. The District Court, weighing the subject matter of the patent in suit for invention, erred in not taking into account all the recitations in each of the claims of the patent in suit.

3. The District Court, weighing the subject matter of the patent in suit for invention, erred in not treating the same as a patentable combination of the elements as specified in the claims.

It is clear, from the Notice of Decision (Tr. 26-28), that the Court below considered only the last step of the development of the package at bar, *i. e.*, the widening of the under-side groove of the cover to accommodate the lap joint of the paper-board carton, as the measure of "invention", and we respectfully submit that it erred fundamentally in that regard.

It is not the fact that the patented package was of the prior art except for the accommodation of the cover to a carton with a lap joint, yet it appears that the Court below so regarded it, which leads us to believe that the Court below gave weight to the Hill Patent 2,623,685 (last patent in Defendant's Exhibit B) to which it was not entitled under the law.

That Hill patent illustrates and describes a square paper-board carton (not lap joint) and a square plastic cover with an underside groove to receive the upper margin of

the carton. The feature of the patent is to make the skirt of the cover flexible to facilitate prying it off.

If that patent were prior art against the Poole patent in suit, Mr. Poole's contribution would be limited to the stiffening of the skirt and the widening of the underside groove to accommodate a lap-joint of the carton. There is no evidence here of utility and public acceptance of the Hill structure, against that of the Poole structure, but question of patentable measure of Poole over Hill need not be debated here because Hill is not prior art, under the law, and Poole's patent claims go to complete combinations which Hill does not and can not claim.

Defendant's Exhibit B, containing the Hill patent, was offered entitled "Prior Art Patents"; it was not objected to on the ground that the patent copies were not certified copies, but was objected to on the ground that it contained this Hill patent and that this Hill patent was not a "Prior Art" patent. Upon deletion of the words "Prior Art" from the title the exhibit was received (Tr. 65-67).

Plaintiff's point was and is that, although the application for the Hill patent was filed October 3, 1947, it did not go to issue until 1952, and therefore was not "prior art" against the Poole application for the patent in suit, which was filed on May 10, 1948.

This point was argued at some length at the trial (Tr. 127-135), but it was left for decision on final hearing (see also Tr. 189-190).

Let us make it clear that the objection to the Hill patent lies in its submission *as prior art* from which to measure the inventive quality of the subject matter of the patent in suit.

Defendant contended that the Hill patent is such prior art as to the patent in suit. We respectfully submit that, in so doing, defendant is mistaken as to the law.

The prior art, from which the inventive quality of something new is to be measured, is not to be confused with anticipation, which means *the same invention* earlier by someone else.

There are two "conditions for patentability" sections in the patent statutes, United States Code, Title 35.

Section 102 prescribes the fundamental requirement of novelty, *i. e.*, there must be no anticipation of the subject invention.

Section 103 has to do with patentable quality, *i. e.*, whether or not the thing found to be new over *the prior art* amounts to an invention.

"The prior art" is public knowledge at a given time, from which the inventor departs. That is abundantly clear from the body of law which has been long in the making.

When the Patent Office Examiner considers a patent application, he cites the prior art which he finds pertinent; but he does not take any co-pending patent application into account unless it discloses the same invention.

The Hill invention is not the Poole invention; it lies simply in the flexibility of the skirt 15 of its plastic cover to facilitate prying-off, which Poole did not disclose. Poole, on his disclosure, could not make the single claim of Hill's patent, nor could Hill, on his disclosure, make any claim of Poole's patent; had there been a common invention, interference proceedings would have been in order.

Incidentally, so far as this case is concerned, the filing date of the application for the Hill patent is October 3, 1947, and Mr. Poole had disclosed *his* invention to the personnel of the Crown Cork Specialty Corporation, of which Mr. Hill was president (Tr. 140), prior to that (Tr. 60-65). It is a reasonable deduction that Mr. Hill, learning of Mr. Poole's work, formulated an idea of his own about plastic lids for square full open top paper-board

cartons, and, with entire propriety, proceeded to patent it. Mr. Poole's testimony was not adduced to ante-date Mr. Hill's filing date; there was no occasion for that; it was adduced to relate to the Court the process of the making of the invention at bar—the steps, including the objective to serve a certain purpose, the selections of carton and cover material, the cover construction, the trial-and-error, and its ultimate reduction to practice precisely as shown in the patent drawing, its acceptance by the purchasing public.

Though Mr. Hill's application for patent was filed before Mr. Poole's, it did not become public until long after Poole filed.

It would be strange indeed if an inventor should, under the law, be charged with the burden of exhibiting patentable quality over something concealed against him and the public at the time of his creative act.

And such is not the law.

In *Old Town Ribbon & Carbon Co. v. Columbia R. & C. Mfg. Co.*, 159 F. (2d) 379 (C. C. A. 2nd), the Court said at page 381:

“Foster filed his application over twenty months before Lewis and Menihan filed theirs, but his patent did not issue until after they had filed, and his disclosure was therefore not prior art; if it is to invalidate their claims it must be because he was the ‘prior inventor’.”

In *re Spencer*, 47 F. (2d) 806, the Court of Customs and Patent Appeals said at page 807:

“The application of the appellant having been filed prior to the issuance of the Schwimmer patent, said patent cannot be cited here as a reference showing the prior art. *Bates v. Coe*, 98 U. S. 31, 25 L. Ed. 68; *Gray Tel. Pay Station v. Baird Mfg. Co.* (C. C. A.), 174 F. 417; *Johns-Pratt Co. v. E. H. Freeman Electric Co.* (D. C.), 201 F. 356, affirmed in *E. H. Freeman*



*Electric Co. v. Johns-Pratt Co.* (C. C. A.), 204 F. 288. We shall therefore disregard this reference in considering the matter.”

In *Gray Telephone Pay Station Co. v. Baird Mfg. Co.*, 174 F. 417 (C. C. A. 7th), the Court said at page 421:

“Defendant cites Gentry patent, No. 516,433, granted March 13, 1894, for a telephone toll station and Alexander patent, No. 544,077, granted August 6, 1895, for improvement in coin-signal apparatus for telephone pay stations. The application for the patent in suit was filed November 17, 1893. It thus appears that at the time the application for the patent in suit was filed these two alleged anticipating patents were not in the prior art, and cannot be availed of as anticipations. *Bates v. Coe*, 98 U. S. 31, 25 L. Ed. 68; *Anderson v. Collins*, 122 Fed. 451, 58 C. C. A. 669; *Eck v. Kutz*, 132 Fed. 758; Walker on Patents, § 70; Robinson on Patents, § 331, and note, 332, 334; *Barnes v. Sprinkler Co.*, 60 Fed. 605, 9 C. C. A. 154.”

In *American Graphophone Co. v. Emerson Phonograph Co.*, 255 F. 574 (D. C. S. D. New York), the Court said at page 578:

“Defendants offered in evidence the Clark and Johnson patent, No. 624,625, granted May 9, 1899, but applied for prior to the date of the Jones application. This is not prior art in this case. *Autosales Gum & Choc. Co. v. Ryede* (D. C.), 138 C. C. A. 648, 222 Fed. 956, affirmed 223 Fed. 1021, and cases cited.”

Since the Hill patent is neither for the same invention as Mr. Poole's, and since under the law it is not prior art against which to measure invention by Mr. Poole under the statute, it has no pertinency in this case.

Although quoting this Court (Tr. 27) in *New York Scaffolding Co. v. Whitney*, 224 F. 452, on patentability of a new and useful combination of old elements, the Court below, after pointing out that there must still be “invention” as distinguished from mere mechanical skill, states:

“The Court is convinced that any reasonably competent person skilled in the art, if presented with the problem of providing a cover for a lap-jointed carton, could have produced what Poole produced and, in so doing, would not have gone beyond the simple skills known and practiced in the art.”

That is a factor, to be sure, but the subject matter of the patent in suit is considerably more than that, as will be clear from the patent, its file history (Pl. Ex. 5), and the testimony of Mr. Poole, who assumed the stand as a fact witness to the features of the ultimate package for its intended purpose, which features are variously recited in the patent claims.

The carton is lap joint for economical manufacture, it is open top for facilitating filling and, more important, the removal of the contents, and is rectangular for compact storage; the cover must therefore also be rectangular, which means that it is incapable of twisting application to the container body, like the cover of a pill-box or baking powder can; it must be applicable by simple downward hand pressure. The cover is a one-piece plastic molding for economical manufacture, low co-efficient of expansion and contraction, and for re-use, its under-side peripheral recess tapered upwardly for tight frictional engagement with the carton wall margins by such simple downward hand pressure; and the enlargement of the underside recess to receive the lap joint of the carton insures uniformity on the downward hand pressure and avoids breaking. The file history shows that all of the above characteristics were taken into account in the allowance of the claims of the patent.

All the claims, like the claims of most patents are combination claims. Even Claims 2, 4, 5 and 6, which are for the lid only, are combination claims; they combine a plurality of elements which individually may be old, the nature of the carton body for which it is adapted being

stated or implied; Claims 1 and 3 include the carton body as an element.

We respectfully submit that all the claims of the patent are true combination claims, the elements cooperating to the end of a new and useful package.

This Court has contributed extensively to the body of law in this regard, and we simply submit our interpretation of the facts as established by the evidence.

---

It is now in order to consider the prior art contained in Defendant's Exhibit B, and the testimony of Mr. Comstock, defendant's expert, with reference thereto. Mr. Comstock, the only witness called on behalf of defendant, is a member of the Bar and an experienced patent practitioner, and his testimony leaves us with no course but to assume that we are as able as he to understand the patent in suit, to gauge its scope, and to compare or contrast its substance with that of the prior art.

The art has no depths which necessitate a technical expert; the facts can readily be understood by Court and counsel. Plaintiff produced no expert, so-called; Mr. Poole was an experiential witness; he testified on facts, no opinions.

Of the six patents, other than Hill (Hill is not prior art), in Defendant's Exhibit B, Drake 1,325,930 and Kurz 1,969,496 were references in the Patent Office in the Poole application and were disposed of there.

The Drake Patent is for the combination of a circular molded pulp fiber receptacle, having an unfinished or raw edge at its open end, and a circular cap of thin somewhat-yielding metal formed with a flared underside groove to receive such edge, the purpose being to force the two elements, we assume naturally by a downward twisting motion, to conform to each other.

The Kurz Patent shows a plastic beverage shaker, the body being of the tumbler type and the cover being circular dome-shape, fitting into the margin of the body.

It is understandable why these references were disposed of in the Patent Office.

It is also understandable why the other prior art patents in Defendant's Exhibit B were not cited by the Patent Office Examiner.

The Rutkowski Patent 2,155,022 shows a tubular wound-paper body with a circular metal bottom and a two-part circular metal cover forming a circular under-side groove to receive the margin of the body, one form (Fig. 7) showing the groove flared for wedging action. There is no lap-joint and the cover is presumably factory-applied, and, if by hand, by twisting manipulation.

The Moore Patent 2,381,508 is for a build-up shipping container. The body (called the shell) is rectangular and has a lap joint, and the top and bottom comprise *partially formed members which are built to the body in the process of completing the package*; neither is a completed unit like Mr. Poole's lid. They are partially formed blanks with uniform end flanges providing the beginnings of a groove, and a wooden block to fit in the depression formed by the flanges; and, in final closing of the container with its contents, the flanges are nailed through the body wall to the block, regardless of whether the wall, at that point, is of one thickness or two (see Figure 3).

The Van Saun Patent 2,392,959 (incidentally, a patent of plaintiff) is for a paperboard drum for waxes, asphalt, resins and like materials, which are packaged in hot liquid condition and then allowed to solidify in the drum. It has a circular body with a lap-joint, and has a circular top and bottom, like the cover of a pill box, stapled to the body on packing. It is for heavy use, and the top and bottom are

strengthened by an auxiliary disc which defendant asserted below to define an annular recess corresponding to the peripheral recess of the patent in suit; a far-fetched assertion, since the recess referred to has a depth of only the paper-board thickness of the disc, and a width greater than the body wall thickness, even where the body wall is double (lap-joint); there is no intention or desire for a tight friction fit and no peripheral groove of the character and function of the peripheral groove of the patent in suit.

In addition to the copy of the Van Saun patent in Defendant's Exhibit B, defendant offered, as its Exhibit A, a certified copy of the file wrapper and contents of that patent, and plaintiff objected to it as immaterial (Tr. 74); see colloquy, Tr. 74-78, 82-86, 168-169). The Court received the exhibit, subject to argument on final hearing; the subject was briefed but there was no specific ruling thereon thereafter. It is still plaintiff's position that the exhibit is immaterial.

The patent itself issued on January 15, 1946 and is definitely of the prior art with reference to the Poole invention, having issued more than one year prior to the filing of the Poole application (May 10, 1948). Whatever the Van Saun structure, it is spelled entirely by the patent itself, and the file history can neither add to nor detract from it.

So far as the merits of the case are concerned, it is immaterial to plaintiff whether the Van Saun file history is in or out, but there is no point in encumbering the evidence with it or burdening the Court about it.

The Van Saun drum utterly fails to meet the subject matter of the Poole patent in suit, as above pointed out, and the Poole subject matter is patentable over it.

The Merkle Patent 2,399,241 shows a rectangular container with a lap joint, but is of no consequence here because the cover is permanently secured and sealed to the

body by an adhesive and by heat and pressure, except for the pouring lip, to which the patent is directed and which is closed and sealed after filling. It is not a friction cover, and has no concern over the lap joint.

Defendant's Exhibits C and D, as previously pointed out, are merely argumentative sketches, obviously intended to measure the patent in suit by the widened portions of the under-side groove in the cover. As we have pointed out, that is an item in the patented structure, but the claimed combinations must be taken as a whole.

As to the testimony of Mr. Comstock, the direct examination is simply the presentation of an argument by dialogue, (1) treatment of the patents contained in Defendant's Exhibit B, (2) coupling of references to meet the claims of the patent in suit; and (3) assertion of no invention in the patent in suit:

## (1)

This is a matter of the facts, and we think we have made the necessary refutations above.

## (2)

The law frowns upon the invalidating of patent claims by the *ex post facto* manufacture of a "reference" from a plurality of independent sources.

In *Bates v. Coe*, 98 U. S. 31, the Supreme Court said, at page 48:

"Where the thing patented is an entirety, consisting of a single device or combination of old elements, incapable of division or separate use, the respondent cannot escape the charge of infringement by alleging or proving that a part of the entire thing is found in one prior patent or printed publication or machine, and another part in another prior exhibit, and still another part in a third one, and from the three or any

greater number of such exhibits draw the conclusion that the patentee is not the original and first inventor of the patented improvement.”

In *Parks v. Booth*, 102 U. S. 96, the Supreme Court said, at page 103:

“Most or all of the inventions described in those publications bear more or less resemblance to that claimed by the complainant, and it may be that if it were allowable to test the validity of the invention in question by comparing the same with the whole as if embodied in a single exhibit, the evidence might be sufficient to support the views of the respondents in respect to the defence under consideration. Were that allowable it might well be suggested that the screen is found in one, the box in another, and the means to produce the lateral shake in a third, and so on to the end; but it would still be true that neither the same combination in its entirety nor the same mode of operation is described in any one of the patents or printed publications given in evidence.”

In *Ry-Lock Company v. Sears, Roebuck & Co.*, 227 F. (2) 615 (1955), the Court of Appeals for the Ninth Circuit said, at page 618:

“Hence, a finding which, as here, picks out one element in one prior patent and another element in another prior patent as a demonstration of anticipation, is manifestly insufficient to overcome the presumption arising from the issuance of the patent, a presumption reemphasized by the existing Act.”

In *Williams Mfg. Co. v. United Shoe Mach. Corp.*, 121 F. (2d) 273, the Court of Appeals for the Sixth Circuit said, at page 278:

“\* \* \* It is not to be struck down by the familiar expedient of picking out old elements of the prior art and speculatively combining them when in practice they have never been combined, though the need for a machine of the type disclosed had long been recog-

nized. The claims of McFeely in suit are valid and infringed.”

In *Stebler v. Riverside Heights Orange Growers' Ass'n.*, 205 F. 735, the Court of Appeals for the Ninth Circuit said, at page 738:

“True, we may pick out one similarity in one of these devices, and one in another, and still one in another, and, by combining them all, anticipate the inventive idea expressed in the Strain patent, but the combination constituting the invention is not found in any one of them. As we had occasion to say in *Los Alamitos Sugar Co. v. Carroll*, 173 Fed. 280, 97 C. C. A. 446:

‘It is not sufficient to constitute an anticipation, that the devices relied upon might, by a process of modification, reorganization, or combination, be made to accomplish the function performed by the device of the patent.’ *Western Electric Co. v. Home Tel. Co.* (C. C.), 85 Fed. 649; *Topliff v. Topliff*, 145 U. S. 156, 12 Sup. Ct. 825, 36 L. Ed. 658; *Gunn v. Bridgeport Brass Co.* (C. C.), 148 Fed. 239; *Ryan v. Newark Co.* (C. C.), 96 Fed. 100; *Simonds R. M. Co. v. Hathorn Mfg. Co.* (C. C.), 90 Fed. 201-208; *Gormully & J. Co. v. Stanley Cycle Co.* (C. C.), 90 Fed. 279; *Merrow v. Shoemaker* (C. C.), 59 Fed. 120.’ ”

In *Robertson Rock Bit Co. v. Hughes Tool Co.*, 176 F. (2d) 783 (C. C. A. 5th), the Court said, at page 789:

“It will not do, as appellant tries to do, to cull from one and another of the prior patents elements of the combinations in suit. They must show not that some of the elements are present in the prior patents but that the combination is. The evidence as a whole is not sufficient to overcome the presumption attending their granting.”



## (3)

This comes under the fourth specification of errors, which we repeat:

4. The District Court erred in finding the structure of the patent in suit wanting in invention and in finding that producing it involved no more than ordinary skill of the art.

The defense of "no invention" is always resorted to when a definitive defense is not at hand or fails. Hence, it presents a question pondered by the Courts ever since the beginning of the patent system. Every case on this issue is a case of its own; it depends upon the evidence and how the facts impress the Chancellors. As Mr. Justice Brown said in *McClain v. Ortmyer*, 141 U. S. 419, at pages 426-427:

"To say that the act of invention is the production of something new and useful does not solve the difficulty of giving an accurate definition, since the question of what is new as distinguished from that which is a colorable variation of what is old, is usually the very question in issue. To say that it involves an operation of the intellect, is a product of intuition, of something akin to genius, as distinguished from mere mechanical skill, draws one somewhat nearer to an appreciation of the true distinction, but it does not adequately express the idea. The truth is the word cannot be defined in such manner as to afford any substantial aid in determining whether a particular device involves an exercise of the inventive faculty or not. In a given case we may be able to say that there is present invention of a very high order. In another we can see that there is lacking that impalpable something which distinguishes invention from simple mechanical skill. Courts, adopting fixed principles as a guide, have by a process of exclusion determined that certain variations in old devices do or do not involve invention; but whether the variation relied

upon in a particular case is anything more than ordinary mechanical skill is a question which cannot be answered by applying the test of any general definition."

No personnel of defendant appeared at the trial. The story of its activities was adduced entirely by plaintiff. We do not know if its accused lids were copied from plaintiff's lids (by 1950, millions of plaintiff's lids as illustrated in the Poole patent had gone out to the public), or were independently inspired (as might be inferred from the fact that the accused lids are marked "PAT. PEND.>").

In either case, its contention that the patent in suit is invalid for lack of invention is to be materially discounted.

The statement of Judge Hough, in *Kurtz et al. v. Bell Hat Lining Co., Inc.*, 280 Fed. Rep. 277, 281 (C. C. A. 2nd), has been frequently quoted in the decisions:

"The imitation of a thing patented by a defendant, who denies invention, has often been regarded, perhaps especially in this circuit, as conclusive evidence of what the defendant thinks of the patent and persuasive of what the rest of the world ought to think."

In *Steiner Sales Co. v. Schwartz Sales Co.*, 98 F. (2d) 999 (C. C. A., 10th), the Court said, p. 1005:

"The fact that the Steiner cabinets have enjoyed marked commercial success and that Schwartz has endeavored to share therein by appropriating the teachings of patents 1,426,121 and reissue 17,352 lends strong support to our conclusion that the conception of these devices constitutes patentable invention."

In *H. D. Smith & Co. v. Peck, Stow & Wilcox Co.*, 262 Fed. Rep. 415, the Court said, p. 417:

"This willingness of the purchasing public to pay is a practical demonstration of its substantial value. The appellant's conduct in copying the structure and shape of the appellee's structure is a strong indication that

it, too, appreciates the value of this advance in the art. We conclude that the combination constitutes invention, and that the patent is valid.”

From *Ric-Wil Co. v. E. B. Kaiser Co.*, 179 F. (2d) 401 C. of A., 7th, 1950), p. 404:

“Defendant’s imitation of the patent structure is another indication of invention, *Kurtz et al. v. Bell Hat Lining Co., Inc.*, 2 Cir., 280 F. 277, 281; *Fones v. American Specialty Co.*, D. C., 38 F. 2d 639, 642; *Gairing Tool Co. v. Eclipse Interchangeable Counterbore Co.*, 6 Cir., 48 F. 2d 73, 75; *Sandy MacGregor Co. et al. v. Vaco Grip Co.*, 6 Cir., 2 F. 2d 655, 656.”

In *Town et al. v. Willis*, 85 F. Supp. 483 (D. C. W. D., Mo., 1949), the Court said, p. 487:

“It would seem that defendant’s position in denying that the device is patentable is further weakened by the fact that he filed an application for a patent on his own device—the accused device—which is practically identical in shape, material and construction, and which performs the same function in the same manner.”

On the appeal, 182 Fed. 2nd 892, the Court of Appeals 8th) said (p. 895):

“Taking into consideration the presumption of validity which attends the grant of the patent, the age of the problem upon which Town was working, the reception which the patented device received from the public as evidenced by its commercial success, the conceded need for some such device, the inferences which reasonably may be drawn from the fact that the defendant imitated the device, *Charles Peckat Mfg. Co. v. Jacobs*, *supra*, page 801 of 178 F. 2d, and that he obviously regarded such a device as patentable (as is indicated by his application for a patent on the accused device, filed in December, 1944), we think that the findings of the District Court that the patent in suit was valid and that Claim 1 was infringed, were not clearly erroneous.”

We quote from the above cases only because facts in them are so closely akin to facts here.

### Conclusion.

Here, we quote again the remaining two specifications of errors:

5. The District Court erred in holding the patent in suit invalid and void, in dismissing the complaint, in sustaining defendant's counterclaim, and in awarding costs to defendant.

6. The District Court erred in not holding the patent in suit valid and infringed, in not granting the relief prayed for in the complaint, and in not dismissing the counterclaim, with costs to plaintiff.

The judgment of the Court below should be reversed, and plaintiff granted the relief prayed in its complaint.

Respectfully submitted,

BROWN, JACKSON, BOETTCHER & DIENNER,  
ARTHUR H. BOETTCHER,  
53 W. Jackson Blvd.,  
Chicago 4, Illinois,  
*Counsel for Appellant.*

J. CALVIN BROWN,  
704 S. Spring Street,  
Los Angeles 14, California,  
*Attorney for Appellant.*

No. 15434

---

---

United States  
Court of Appeals  
For the Ninth Circuit

—

AH PAH REDWOOD CO., a Corporation,  
Petitioner,  
vs.

COMMISSIONER OF INTERNAL REVENUE,  
Respondent.

—

Transcript of Record

**FILED**

MAY - 8 1957

Petition to ~~Review a Decision of the~~ Tax Court  
of the United States



No. 15434

---

---

United States  
Court of Appeals  
For the Ninth Circuit

—

AH PAH REDWOOD CO., a Corporation,  
Petitioner,

vs.

COMMISSIONER OF INTERNAL REVENUE,  
Respondent.

—

Transcript of Record

—

Petition to Review a Decision of the Tax Court  
of the United States





## INDEX

---

[Clerk's Note: When deemed likely to be of an important nature, errors or doubtful matters appearing in the original certified record are printed literally in *italic*; and, likewise, cancelled matter appearing in the original certified record is printed and cancelled herein accordingly. When possible, an omission from the text is indicated by printing in *italic* the two words between which the omission seems to occur.]

	PAGE
Answer .....	14
Appearances .....	1
Certificate of Clerk .....	83
Decision .....	28
Exhibits:	
No. 1—A—Agreement .....	57
2—B—Agreement .....	72
Findings of Fact and Opinion.....	16
Motion for Revision of Decision .....	76
Notice of Appeal .....	85
Notice of Filing Petition for Review .....	32
Order Enlarging Time .....	82
Petition .....	3
Petition for Review .....	29
Statement of Points on Which Appellant Intends to Rely on Appeal .....	86
Transcript of Proceedings .....	33

	INDEX	PAGE
Witnesses:		
Adkins, J. J.		
—direct	.....	38
—cross	.....	42
Carpenter, Charles E.		
—direct	.....	53
Herndon, James M.		
—direct	.....	46
—cross	.....	51

## APPEARANCES

KOERNER, YOUNG, McCOLLOCH &  
DEZENDORF,

JAMES C. DEZENDORF,

800 Pacific Bldg.,

Portland 4, Oregon,

For Petitioner.

CHARLES K. RICE,

Asst. U. S. Attorney General;

LEE A. JACKSON,

Attorney, Dept. of Justice,

Department of Justice,

Washington 25, D. C.,

For Respondent.



The Tax Court of the United States

Docket No. 50695

AH PAH REDWOOD CO., a California Corporation,  
tion,

Petitioner,

vs.

COMMISSIONER OF INTERNAL REVENUE,

Respondent.

PETITION

The above-named petitioner hereby petitions for a redetermination of the deficiency set forth by the Commissioner of Internal Revenue in his notice of deficiency (Office of the Director of Internal Revenue, Lincoln Bldg., 222 S. W. Fifth Ave., Portland 4, Oregon, A:R:90D:ENH) dated June 18, 1953, and, as a basis of its proceeding, alleges as follows:

I.

The petitioner is a corporation organized under the laws of California whose mailing address is 1101 S. W. Fifth Ave., Portland, Oregon. The returns for the period here involved were filed with the Director of Internal Revenue for the District of Oregon.

II.

The notice of deficiency, a copy of which is attached hereto and made a part of this petition by reference, is dated June 18, 1953.

## III.

The taxes in controversy are income taxes for the calendar years 1947 to 1950, both dates inclusive, as follows:

1947	Tax	None	Sec. 291 penalty	None
1948	Tax	\$ 2,654.84	Sec. 291 penalty	\$ 663.71
1949	Tax	35,649.37	Sec. 291 penalty	8,912.35
1950	Tax	(665.38)	Sec. 291 penalty	(166.35)
	Total.....	\$37,638.83		\$9,409.71

## IV.

The determination of tax set forth in said notice of deficiency is based upon the following errors:

1. The Commissioner erred in increasing petitioner's income in each taxable year above cited by a redistribution of the capital gain on the sale of timber.

2. The Commissioner erred in the computation of the basis for and unit value of timber severed from the company's timber tracts.

## V.

The facts upon which petitioner relies are as follows:

1. The timber owned by petitioner is in the nature of a capital asset and is therefore entitled to the treatment applicable to capital gains and losses.

2. The basis for the computation of the gain or loss on the severance of timber is erroneous due to a large under-run experienced by petitioner and

redetermination of the basis is necessary to determine the true basis.

Wherefore, petitioner prays that the Court may hear the proceeding and:

1. Determine that the Commissioner erred in increasing petitioner's taxable income in the years above stated by a redistribution of the capital gain on sale of timber.

2. Determine that the Commissioner erred in determining the basis of timber severed by petitioner.

3. Grant such other and further relief as the Court may deem proper.

/s/ WM. F. MEYER,  
Counsel for Petitioner.

U. S. Treasury Department  
Office of the Director of Internal Revenue  
Lincoln Bldg., 222 S. W. 5th Ave.  
Portland 4, Oregon

June 18, 1953.

Ah Pah Redwood Co.,  
1101 S. W. Fifth,  
Portland, Oregon.

Dear Sirs:

You are advised that the determination of your income tax liability for the taxable years December

31, 1947, 1948 and 1949, discloses a deficiency of \$38,304.21 in tax and \$9,576.06 in penalty and that the determination of your income tax liability for the taxable year ended December 31, 1950, discloses an overassessment of \$665.38 in tax and \$166.35 in penalty, as shown in the statement attached.

A copy of this letter and statement has been mailed to your representatives, Mr. Wm. F. Meyer and Mr. A. L. Lukens, 538 Mead Building, Portland, Oregon, in accordance with the authority contained in the power of attorney executed by you.

In accordance with the provisions of existing internal revenue laws, notice is hereby given of the deficiency or deficiencies mentioned.

Within 90 days from the date of the mailing of this letter you may file a petition with the Tax Court of the United States, at its principal address, Washington 4, D. C., for a redetermination of the deficiency. In counting the 90 days you may not exclude any day unless the 90th day is a Saturday, Sunday or legal holiday in the District of Columbia in which event that day is not counted as the 90th day. Otherwise Saturdays, Sundays and legal holidays are to be counted in computing the 90-day period.

Should you not desire to file a petition, you are requested to execute the enclosed form and forward it to Director of Internal Revenue, Audit Division,



Lincoln Building, 222 S. W. Fifth Avenue, Portland 4, Oregon. The signing and filing of this form will expedite the closing of your return by permitting an early assessment of the deficiency or deficiencies, and will prevent accumulation of interest, since the interest period terminates 30 days after receipt of the form, or on the date of assessment, or on the date of payment whichever is earlier.

Very truly yours,

T. COLEMAN ANDREWS,  
Commissioner.

By /s/ R. C. GRANQUIST,  
Director.

Enclosures :

Statement

Form 1276

Agreement Form

Claim Form 843

DLM

Ah Pah Redwood Co.  
1101 S. W. Fifth  
Portland, Oregon

Income tax liability for the taxable years ended December 31, 1947, 1948, 1949 and 1950.

Years	Income Tax	Sec. 291 Penalty	Income Tax	Sec. 291 Penalty	Income Tax	Sec. 291 Penalty
1947	\$ 343.22	\$ 85.81	\$ 343.22	\$ 85.81	0	0
1948	6,356.01	1,589.00	3,701.17	925.29	\$ 2,654.84	\$ 663.71
1949	52,421.71	13,105.43	16,772.34	4,193.08	35,649.37	8,912.35
1950	4,165.89	1,041.47	4,831.27	1,207.82	(665.38)	(166.35)
Totals	<u>\$63,286.83</u>	<u>\$15,821.71</u>	<u>\$25,648.00</u>	<u>\$6,412.00</u>	<u>\$37,638.83</u>	<u>\$9,409.71</u>

In making this determination of your income tax liability, careful consideration has been given to the report of examination attached to the letter dated April 22, 1953.

Inasmuch as you failed to make and file a return for the taxable years 1947, 1948, 1949 and 1950, within the time prescribed by law, the 25 per cent of the tax has been added thereto in accordance with the provisions of Section 291 (a) of the Internal Revenue Code.

After processing, the overassessment shown herein will be applied in accordance with the provisions of Section 322 (a) of the Internal Revenue Code, provided that you fully protect yourself against the running of the statute of limitations with respect to the apparent overassessment referred to in this letter, by filing with the Director of Internal Revenue for your district, a claim for refund on Form 843, a copy of which is enclosed, the basis

Adjustments to Income  
Year: 1947

Net income as disclosed by return, Form 1120.....	\$1,634.38
Unallowable deductions and additional income:	
(a) Ordinary income .....	2,826.19
Total .....	<u>\$4,460.57</u>
Nontaxable income and additional deductions;	
(b) Capital gain .....	\$2,826.19
Net income adjusted.....	<u>\$1,634.38</u>

Explanation of Adjustments

(a) It has been determined that the sale of timber held less than six months at a profit of \$2,826.19 is taxable as ordinary income instead of capital gain, your income is increased accordingly.

(b) Since the above adjustment was reported as a capital gain in the amount of \$2,826.19 your adjusted income is reduced by a like amount.

Computation of Tax

Net income adjusted.....		\$ 1,634.38
Normal tax: 15% of \$1,634.38....	\$ 245.16	
Surtax: 6% of \$1,634.38.....	98.06	
Income tax liability.....	\$ 343.22	
25% Delinquent Penalty.....		\$85.81
Tax and penalty previously assessed .....	343.22	\$85.81
Deficiency .....	None	None

Taxable Year Ended December 31, 1948  
Adjustments to Income

Net income as disclosed by return .....	\$16,526.81
Unallowable deductions and additional income:	
(a) Ordinary income from sale of property.....	14,891.96
(b) Interest income .....	10,912.24
Total .....	<u>\$42,331.01</u>

Taxable Year Ended December 31, 1948—(Continued)

Nontaxable income and additional deductions:

(c) Legal expense .....	\$ 15.00	
(d) Capital gain .....	14,891.96	14,906.96
		<hr/>
Net income adjusted.....		\$27,424.05

Explanation of Adjustments

(a) It has been determined that the profit of \$14,891.96 from the sale of timber to Coast Redwood Co. is reportable as ordinary income instead of capital gain as reported in your return, your net income is increased accordingly.

(b) It has been determined that your interest income was understated on your return in the amount of \$10,912.24 and your net income is increased by such amount.

(c) Legal expense was understated in your return by the amount of \$15.00, and your net income is reduced by this amount.

(d) Since the \$14,891.96 (adjustment (a) above) was reported in your return as a capital gain in error, your adjusted income is reduced by a like amount.

Computation of Tax—Alternative Method

Net income adjusted.....		\$ 27,424.05
Less: Excess of net long-term capital gain over net short-term capital loss .....		5,511.57
		<hr/>
Normal and surtax net income .....		\$ 21,912.48
Normal tax: 5,000.00x15% \$ 750.00		
15,000.00x17% \$ 2,550.00		
1,912.48x19% \$ 363.37	\$ 3,663.37	
Surtax: \$21,912.48x 6%	1,314.75	
	<hr/>	
Partial tax .....	\$ 4,978.12	Sec. 291
Plus: 25% of \$5,511.57.....	1,377.89	Penalty
	<hr/>	<hr/>

Computation of Tax—Alternative Method—(Continued)

Correct income tax liability and penalty .....	\$ 6,356.01	\$ 1,589.00
Income tax liability and penalty as disclosed by return, Account No. CP8-10011-52 .....	3,701.17	925.29
	<hr/>	<hr/>
Deficiency in income tax and penalty .....	\$ 2,654.84	663.71

Taxable Year Ended Dec. 31, 1949  
Adjustments to Income

Net income as disclosed by return	\$ 59,260.61
Unallowable deductions and additional income:	
(a) Ordinary income from sale of property.....	17,564.14
(b) Capital gain adjust- ment .....	127,535.80
(c) Interest income .....	7,345.81
	<hr/>
Total .....	\$211,706.36
Nontaxable income and additional deductions:	
(d) Legal expense .....	275.00
	<hr/>
Net income adjusted.....	\$211,431.36

Explanation of Adjustments

(a) It has been determined that your profit of \$17,564.14 (Sale Price \$82,972.27 less cost \$65,408.13) from the sale of timber to Coast Redwood Co. is reportable as ordinary income instead of capital gains, your income is increased accordingly. (Your return reported \$17,603.57 capital gain, a difference of \$39.43.)

(b) It has been determined that your capital gain on sale and repossession of

Foster Big Tree amounted to a total of	\$194,625.17	\$194,625.17
Less: reported on the Foster Big Tree	\$ 49,485.80	
and less reported on Coast Redwood Co.		
(see (a) above).....	17,603.57	67,089.37

resulting in a net capital adjustment as

above of .....		\$127,535.80
----------------	--	--------------

and increasing your income by such amount.

(c) It has been determined that your income from interest was understated in the amount of \$7,345.81, and your income has been increased accordingly.

(d) It has been determined that your legal expense was understated in your return by the amount of \$275.00, your net income is reduced by such amount.

#### Computation of Tax—Alternative Method

Net income adjusted.....		\$211,431.36
Less: Excess of net long-term capital gain over net short-term capital loss....		194,625.17
Normal and surtax net income .....		\$ 16,806.19
Normal tax: \$ 5,000.00x15% \$ 750.00		
11,806.19x17% 2,007.05	\$ 2,757.05	
Surtax: 16,806.19x 6%	1,008.37	
Partial tax .....	\$ 3,765.42	Sec. 291
Plus: 25% of \$194,625.17.....	48,656.29	Penalty
Correct income tax liability and penalty .....	\$52,421.71	\$ 13,105.43
Income tax liability and penalty as disclosed by return, Account No. CPS-10012-52 .....	16,772.34	4,193.08
Deficiency in income tax and penalty .....	\$35,649.37	\$ 8,912.35

Taxable Year Ended December 31, 1950

Adjustments to Income

Net income as disclosed by return	\$ 21,005.51
Unallowable deductions and additional income:	
(a) Ordinary income from sale of property.....	4,930.08
	<hr/>
Total .....	\$25,935.59
Nontaxable income and additional deductions:	
(b) Capital gain adjust- ment .....	7,823.01
	<hr/>
Net income adjusted.....	\$ 18,112.58

Explanation of Adjustments

(a) It has been determined that your profit of \$4,930.08 (sale price \$23,289.52 less cost \$18,359.44) from the sale of timber to Coast Redwood Co. is ordinary income instead of capital gains, your income is increased by such amount.

(b) It has been determined that your capital gain from sale of timber is \$24,094.89 instead of \$31,917.90, a difference of \$7,823.01, and your income has been reduced accordingly.

Computation of Tax

Net income adjusted.....		\$ 18,112.58
Normal tax: \$18,112.58x23%	\$4,165.89	Sec. 291 Penalty
	<hr/>	<hr/>
Total income tax liability and penalty .....	\$4,165.89	\$1,041.47
Income tax liability and penalty as disclosed by return,		
No. CP8-10013-52 .....	4,831.27	1,207.82
	<hr/>	<hr/>
Overassessment of income tax and penalty .....	\$ 665.38	\$ 166.35

Duly verified.

Received and filed September 16, 1953, T.C.U.S.

Served September 17, 1953.

[Title of Tax Court and Cause.]

## ANSWER

Comes Now the Commissioner of Internal Revenue, by his attorney, Kenneth W. Gemmill, Acting Chief Counsel, Internal Revenue Service, and for answer to the petition filed herein, admits, denies and alleges as follows:

1. Admits the allegations contained in paragraph I of the petition.

2. Admits the allegations contained in paragraph II of the petition.

3. Denies the allegations contained in paragraph III of the petition. Alleges that the deficiencies as determined by the Commissioner are in income tax and delinquency penalties for the taxable years 1948 and 1949, in the amounts as shown in the following tabulation, all of which are in dispute:

Year	Income tax	Delinquency Penalty
1948	\$ 2,654.84	\$ 663.71
1949	35,649.37	8,912.35

Specifically denies that there is in controversy, in this proceeding, any amount, whatsoever, of income tax or penalty for either of the taxable years 1947 or 1950.

4. Denies that he erred in his determination of the deficiencies in income tax and penalties as shown in the notice of deficiency from which the petitioner's appeal is taken. Specifically denies that



he erred in the manner and form as alleged in paragraph IV (1) and (2) of the petition.

5. Denies the allegations contained in paragraph V (1) and (2) of the petition.

6. Denies generally and specifically each and every material allegation contained in the petition not hereinbefore specifically admitted, qualified or denied.

Wherefore, it is prayed that the petitioner's appeal be denied and that the Commissioner's determination of deficiencies be approved.

/s/ KENNETH W. GEMMILL,  
Acting Chief Counsel,  
Internal Revenue Service.

Of Counsel:

WOOLVIN PATTEN,  
Acting Regional Counsel;

E. C. CROUTER,  
Acting Appellate Counsel;

JOHN H. PIGG,  
Attorney, Internal Revenue  
Service.

Filed November 10, 1953, T.C.U.S.

[Title of District Court and Cause.]

## FINDINGS OF FACT AND OPINION

1. Held, the amounts received by petitioner in 1948 and 1949 from Coast Redwood Co. for Timber cut by the latter in those years from the property of petitioner are properly taxable as ordinary income.

2. Where petitioner did not in fact ascertain at any time during 1948 and 1949 a discrepancy between its actual timber resources and prior estimates, even though such fact was at times readily ascertainable, a revision of petitioner's depletion allowance effective for the years 1948 and 1949 is not warranted under section 23 (m), I.R.C. of 1939.

JAMES C. DEZENDORF, ESQ.,

For the Petitioner.

WENDELL M. BASYE, ESQ.,

For the Respondent.

The respondent determined deficiencies in income tax of petitioner, and additions thereto, pursuant to section 291(a) of the Internal Revenue Code of 1939, for failure to file timely returns, for years and in amounts as follows:

Year	Deficiency	Addition to Tax
1948	\$ 2,654.84	\$ 663.71
1949	35,649.37	8,912.35

Respondent's imposition of the additions to tax is not contested. Nor is error assigned with respect to various adjustments made by respondent in his de-

termination. The issues framed by the pleadings and here to be resolved are:

(1) Whether the amounts received by petitioner in 1948 and 1949 from Coast Redwood Co. for timber cut by the latter from the property of petitioner are properly taxable as long-term capital gains.

(2) Whether petitioner's depletion allowance for the taxable years 1948 and 1949 is properly to be adjusted subsequent to the close thereof by revision of the estimated amount of units of timber standing on petitioner's property during such years.

#### Findings of Fact

The stipulation of facts filed by the parties, with exhibits attached, is adopted and, by this reference, made a part hereof.

The petitioner, Ah Pah Redwood Co., is a corporation organized under the laws of California, with its main office at Portland, Oregon. The returns for the periods here involved were filed with the then collector<sup>1</sup> of internal revenue for the district of Oregon. Such returns were filed on a calendar year basis.

Upon its organization in October, 1947, petitioner purchased all the right, title and interest of "the buyer" in a certain purchase agreement (herein-

---

<sup>1</sup>The stipulation, as well as the petition, reads "Director," but this is obviously erroneous inasmuch as such office did not come into being until after the taxable years.

after called the Sage Agreement) and all the timber and land covered thereby, dated December 13, 1946, between Sage Land & Lumber Company, Inc., (hereinafter called Sage), as seller, and Union Bond & Trust Company (hereinafter called Union), as buyer. The timber and land involved are located in Humboldt County, California, and the purchase price paid by petitioner was \$1,443,838.99. Shortly after the purchase of this tract (hereinafter called the Sage Tract), petitioner, in October, 1947, under an oral or implied contract with Coast Redwood Co. (hereinafter called Coast), allowed the latter to begin cutting timber from the Sage Tract and pay therefor \$5.00 per thousand feet as removed. On January 9, 1950, petitioner entered into a formal written agreement with Coast, pursuant to which petitioner agreed to sell all of the timber and land covered by the Sage Agreement to Coast.

In the years, 1948 and 1949, petitioner reported its income on the sales of timber to Coast as long-term capital gains. In so reporting its income on the timber thus sold to Coast, petitioner used the basis for depletion of \$3.941566 per thousand board feet. Respondent also used such basis in computing a portion of the deficiencies here in question. This basis for depletion was computed by both parties by dividing the amount of timber on the Sage Tract, as was shown on Schedule A of the Sage Agreement per the French cruise, which amount petitioner assumed to be the correct quantity thereof, into the total purchase price paid by petitioner for such

agreement. In 1952, petitioner first became aware of the fact that Schedule A of the Sage Agreement erroneously overstated the quantity of timber on the Sage Tract by a substantial amount. Upon an actual cruise made shortly after logging operations ceased in November of 1954, it was ascertained that such overstatement was approximately double the actual amount and that there was a "fall-down" of approximately 48 per cent.

In addition to other sales, petitioner sold 33,883,000 board feet of timber covered by the Sage Agreement to A. K. Wilson Lumber Company in 1950. This quantity of timber was assumed to be the above amount on the basis of the quantities shown in Schedule A to the Sage Agreement. Prior to petitioner's acquisition of the Sage Agreement, International Pacific Pulp and Paper Co. sold 16,022,060 board feet of the timber covered thereby to Coast in the years 1946 and 1947.

### OPINION

Van Fossan, Judge: The first issue is whether the amounts received by petitioner in 1948 and 1949 from Coast for timber cut in those years by the latter from the Sage Tract are properly taxable as capital gains, as urged by petitioner, or as ordinary income, as determined by respondent. The statutes involved are sections 117 (j) (1) and 117 (k) (2) of the Internal Revenue Code of 1939, as amended, the

pertinent provisions of both of which are set forth below.<sup>2</sup> It is petitioner's position that the only question to be resolved under this issue is whether or not its oral arrangement with Coast, whereby Coast commenced logging operations on the Sage Tract, as indicated in our findings above, in October, 1947, shortly after petitioner's acquisition thereof, from

---

<sup>2</sup>Sec. 117. Capital Gains and Losses.

\* \* \*

(j) Gains and Losses From Involuntary Conversion and From the Sale or Exchange of Certain Property Used in the Trade or Business.

(1) Definition of Property Used in the Trade or Business—For the purposes of this subsection, the term "property used in the trade or business" means property used in the trade or business, of a character which is subject to the allowance for depreciation provided in section 23(1), held for more than 6 months, and real property used in the trade or business, held for more than 6 months, which is not \* \* \* (B) property held by the taxpayer primarily for sale to customers in the ordinary course of his trade or business. Such term also includes timber with respect to which subsection (k) (1) or (2) is applicable \* \* \*

\* \* \*

(k) Gain or Loss Upon the Cutting of Timber.

\* \* \*

(2) In the case of the disposal of timber (held for more than six months prior to such disposal) by the owner thereof under any form or type of contract by virtue of which the owner retains an economic interest in such timber, the difference between the amount received for such timber and the adjusted depletion basis thereof shall be considered as though it were a gain or loss, as the case may be, upon the sale of such timber.

which logging operations the amounts in dispute were received, constituted a "disposal" by petitioner of all of the timber standing thereon within the meaning of section 117 (k) (2).

In line with this view, petitioner makes the argument on brief that such oral arrangement was ineffective to pass title to all of the standing timber in question in October, 1947, the date the oral agreement was made, because of the California Statute of Frauds (See §1091, West's Annotated California Codes (Civil); *Anderson vs. Palladine*, 178 P. 553; see, also, 34 Am. Jur. 498), and that it therefore could not and did not constitute a "disposal" of such timber within the ambit of the cited statute at any time prior to the execution of the written agreement in 1950. Further, petitioner advances the theory that while its oral agreement with Coast was not effective as a contract to sell standing timber, it did constitute a license to cut, which license ripened into a contract for the sale of logs upon the severance of each individual tree.

Whether or not petitioner's theory be valid, its application will not constitute a disposition of the issue framed in the pleadings. Thus to narrow the issue is to make the unwarranted assumption that the timber involved in the transaction at issue constituted a capital asset to petitioner at the time of such transaction, within the definition contained in section 117 (a) (1) of the Internal Revenue Code

of 1939,<sup>3</sup> or property used in petitioner's trade or business within the meaning of section 117(j) (1), *supra*. In this connection, respondent makes the point, which we feel to be well taken, that petitioner at no time engaged in any logging activities, but, rather, merely sold the Sage timber to others under arrangements whereby the vendees would do the logging; that these sales of timber were the only business activity entered into by petitioner; that it is thus to be considered as having been engaged in the trade or business of selling timber; and that the timber in dispute, whether or not it was standing, was held for sale to customers in the ordinary course of such business.

The facts found on this record lead to the conclusion that petitioner was engaged in the trade or business of selling timber and that the timber in controversy was held for sale to customers in the ordinary course thereof. Petitioner does not deny the nature of its business activity and the purpose for which the Sage timber was held. Nor does it claim that the timber comes within the definition of section 117 (a) (1), *supra*. In fact, petitioner bases its entire case upon the applicability of section

---

<sup>3</sup>Sec. 117. Capital Gains and Losses.

(a) Definition—as used in this chapter—

(1) Capital Assets—The term “capital assets” means property held by the taxpayer (whether or not connected with his trade or business), but does not include \* \* \* property held by the taxpayer primarily for sale to customers in the ordinary course of his trade or business \* \* \*



117 (j), supra. In this connection, petitioner's position is summed up in its statement on brief that section 117 (j) " \* \* \* includes timber to which Section 117 (k) (2) is applicable and allows capital gain treatment of income therefrom without regard to the nature of the taxpayer's business or the purpose for which the timber is held." [Emphasis supplied.]

The view thus expressed is in direct conflict with the plain wording of the statute relied upon. Section 117 (j), by its own language, specifically excludes from its operation all property held for sale to customers in the ordinary course of business. This being true, the gains derived from the sale of the Sage timber, regardless of the time of such sale, would not qualify for capital gains treatment under either section 117 (a) (1) or section 117 (j).

While there is no direct evidence of the precise terms of the oral cutting contract entered into between petitioner and Coast, such contract, for aught that is shown, looked immediately to the severance and removal of all timber standing upon the Sage Tract. Under the provisions of the Uniform Sales Act which was enacted in California in 1931 (See Title 1, Sales of Goods, Stats. 1931, c. 1070, p. 2234, §1; §§1721-1800, West's Annotated California Codes (Civil, supra), the sale of "things attached to or forming a part of the land," which category includes fructus naturales, or standing timber, pursuant to a contract according to the terms of which the trees are to be severed and removed as soon

as possible, is a sale of goods, i.e., personalty, and not of an interest in land. See §1796, *supra*; Brown, *The Law of Personal Property*, 2d ed., §164. Thus it is, that, in our opinion, petitioner's cutting contract with Coast was fully enforceable by the latter in the California courts and not invalid for noncompliance with the Statute of Frauds. See § 1091, *supra*; see, also, §§ 1723, 1724, *supra*. By being allowed access to the Sage Tract and by beginning its logging operations, Coast partly performed on its contract with petitioner and by such partial performance removed the contract from the application of the Statute of Frauds. *McGinn vs. Willey*, 25 Cal. App. 303, 141 P. 49; cf. *Forbes vs. City of Los Angeles*, 101 Cal App. 781, 282 P. 528; 101 A.L.R. 923; see §1724, *supra*.

Accordingly, it is our view that petitioner's oral agreement with Coast, under either rationale, constituted a disposition of the Sage timber within six months of the acquisition thereof in direct opposition to the specific statutory language defining capital gains. See section 117(k)(2), *supra*, and footnote 2.

The recent case, *L. D. Wilson*, 26 T.C.—(June 7, 1956), is clearly distinguishable from that now before us. There the issues framed were whether the partnership, of which the petitioners therein were members, could be considered the "owner" of the timber in question within the intentment of section 117 (k) (2), *supra*, and, if so, whether the timber cutting arrangement involved was sufficient to constitute a "disposal" of the timber within the scope

of the statute involved. We answered both questions in the affirmative.

In the instant case, albeit the existing oral cutting arrangement between petitioner and Coast constitutes a valid cutting contract for the disposition of the Sage timber, such contract does not meet the prerequisites of a "disposal" within the statutory purview, in that at the time it was entered into, petitioner had been the owner of the Sage timber for a period of less than 6 months. Nor, contrary to the instant case, could the partnership in *L. D. Wilson, supra*, on the facts there present, be considered as having been in the trade or business of selling stumpage to customers in the ordinary course of such business.

In view of all the foregoing, respondent's determination on this point is affirmed.

The second issue involves petitioner's allegation that an erroneous basis for depletion was applied by both petitioner and the respondent to timber cut from its property in the taxable years.

The facts adduced herein show that the amount of recoverable units of timber standing on the Sage Tract was substantially less than the original estimate which was used in computing petitioner's depletion allowance at \$3.941566 per thousand board feet. Petitioner first became aware of the error in 1952 and upon an actual cruise made shortly following the cessation of logging activities in November, 1954, the amount of "fall-down" was ascertained to be approximately 48 per cent.

Petitioner here seeks revision of its depletion allowance for the years 1948 and 1949, citing section 23 (m), Internal Revenue Code of 1939,<sup>4</sup> and our opinion in *Marion A. Burt Beck*, 15 T.C. 642, affd. 194 F. 2d 537, as authorizing such adjustment. Petitioner reasons that since the amount of "fall-down" in its timber resources was readily ascertainable at all times during the taxable years, a revision of its depletion allowance should be made effective for those years. We do not agree.

The Beck case does not stand for the proposition advanced by the petitioner. There the taxpayer was contesting a downward revision by respondent of her depletion allowance for the years there involved. However, the record made in that proceeding was adequate to warrant our finding as a fact that the taxpayer on the basis of facts known and reasonably ascertainable in the taxable years had discovered the discrepancy between the amount of units of ore actually recoverable and the prior estimates thereof. This being true, we sustained respondent's action, saying, in part:

---

<sup>4</sup>Sec. 23. Deductions From Gross Income.

In computing net income there shall be allowed as deductions:

\* \* \*

(m) Depletion \* \* \* In any case in which it is ascertained as a result of operations or of development work that the recoverable units are greater or less than the prior estimate thereof, then such prior estimate (but not the basis for depletion) shall be revised and the allowance under this subsection for subsequent taxable years shall be based upon such revised estimate. \* \* \*

\* \* \* The statute does not imply that the party to whom it would be an immediate tax-wise advantage to suppress the information of a need for adjustment, has any privilege not to come forward and make the necessary correction in the return. \* \* \*

The evidence here affords us no basis for making any finding that petitioner at any time in the taxable years knew or even suspected that its prior estimate of standing timber was erroneous. Albeit such error was readily ascertainable, it was not in fact ascertained at any time within either of the taxable years. In our view, therefore, the revision sought by petitioner does not qualify under the statutory provision that the allowance "for subsequent taxable years shall be based upon such revised estimate." Cf. *Petit Anse Co. vs. Commissioner*, 155 F. 2d 797, certiorari denied 329 U.S. 732. Respondent's determination on this issue is approved.

Reviewed by the Court.

Decision will be entered for the respondent.

Murdock, J., dissenting:

The legislative history of section 117(k) indicates clearly that Congress was trying to give capital gains treatment to timber owners when they disposed of their timber. See *Helga Carlen*, 20 T.C. 573. This taxpayer seems to come precisely within the terms of section 117(k)(2) and, therefore, is entitled to its benefits.

I also have doubt on the depletion issue. The facts in regard to the true content were reasonably ascertainable during the taxable year, and under such circumstances a reasonable allowance for depletion could be based on such ascertainable facts.

Filed and entered September 28, 1956.

Served September 28, 1956.

---

The Tax Court of the United States, Washington  
Docket No. 50695

AH PAH REDWOOD CO.,

Petitioner,

vs.

COMMISSIONER OF INTERNAL REVENUE,

Respondent.

### DECISION

Pursuant to the determination of the Court, as set forth in its Findings of Fact and Opinion, filed September 28, 1956, it is

Ordered and Decided: That there are deficiencies in income tax, and additions to tax, as follows:

Year	Deficiency	Addition to Tax Sec. 291(a)
1948	\$ 2,654.84	\$ 663.71
1949	35,649.37	8,912.35

EUGENE BLACK,

Judge.

Entered October 28, 1956.

Served October 28, 1956.

In the United States Court of Appeals  
for the Ninth Circuit

Tax Court Docket No. 50695

AH PAH REDWOOD CO., a California Corporation,  
Petitioner,

Petitioner,

vs.

COMMISSIONER OF INTERNAL REVENUE,  
Respondent.

PETITION FOR REVIEW

Ah Pah Redwood Co., the Petitioner in this cause, by James C. Dezendorf, counsel, hereby files its Petition for Review by the United States Court of Appeals for the Ninth Circuit of the decision entered by the Tax Court of the United States filed in this matter on September 28, 1956, 26 T.C. No. 149, determining deficiencies in Petitioner's federal income taxes for the calendar years 1948 and 1949 in the respective amounts of \$2,654.84 and \$35,649.37, resulting in additions to tax in the respective amounts of \$663.71 and \$8,912.35, and respectfully shows:

I.

Petitioner, Ah Pah Redwood Co., is a corporation duly organized and existing under and by virtue of the laws of the State of California, with its principal office being located at 1101 S.W. 5th Avenue, Portland, Oregon. The tax returns of Petitioner for the periods here involved were filed with the Collector of Internal Revenue for the District of Oregon, at his office in Portland, Oregon.

## II.

The controversy involves the proper determination of Petitioner's liability for federal income taxes for the calendar years 1948 and 1949.

The Petitioner, in October, 1947, acquired an interest in certain timber and land located in Humboldt County, California, from Union Bond & Trust Company. Under a purchase agreement dated December 13, 1946, Union Bond and Trust Company had contracted to purchase this timber and land from Sage Land and Lumber Company, Inc.

Shortly after the purchase of the land and timber above described, Petitioner entered into an oral or implied agreement with Coast Redwood Co., whereby the latter was permitted to enter upon the land and cut and remove the timber located thereon. Coast Redwood Co. was to pay purchaser \$5.00 per thousand board feet, as removed. All of the timber covered by the agreement with Coast Redwood Co. had been acquired by Petitioner from Union Bond and Trust Company under the agreement of October, 1947.

On January 9, 1950, Petitioner entered into a formal written agreement with Coast Redwood Co., pursuant to which Petitioner agreed to sell to Coast Redwood Co. all of the land and timber acquired by Petitioner from Union Bond and Trust Company in 1947.

For the years 1948 and 1949, Petitioner reported its income on sales of timber to Coast Redwood Co.



as long-term capital gains. On these sales, Petitioner used as a basis for depletion \$3.941566 per thousand board feet. This figure was obtained by using the amount of timber reputedly present on the tract as reflected in a timber cruise furnished Petitioner by Union Bond and Trust Company at the time the property was purchased. Until 1952, Petitioner assumed the amount of timber acquired was correctly stated in the cruise. In 1952, Petitioner realized that the figures relied upon had substantially overstated the amount of timber on the tract, and a new cruise completed in the winter of 1954-1955 indicated a "fall-down" of approximately 48 per cent.

The Commissioner of Internal Revenue held that gains realized by Petitioner from the sales of timber to Coast Redwood Co. should be taxed to Petitioner as ordinary income, and thereupon determined the deficiencies for the calendar years 1948 and 1949, as aforesaid.

### III.

Petitioner, Ah Pah Redwood Co., being aggrieved by the findings and conclusions contained in the findings and opinion of the Court, and by its decision entered pursuant thereto, desires to obtain a review thereof by the United States Court of Appeals for the Ninth Circuit.

/s/ JAMES C. DEZENDORF,  
Counsel for Petitioner.

Duly verified.

Received and filed December 18, 1956. T.C.U.S.

[Title of Court of Appeals and Cause.]

Tax Court Docket No. 50695

NOTICE OF FILING PETITION  
FOR REVIEW

To: Chief Counsel, Internal Revenue Service,  
Washington, D. C.

You are hereby notified that Petitioner, Ah Pah Redwood Co., on the 13th day of December, 1956, mailed for filing with the Clerk of the Tax Court of the United States at Washington, D. C., a Petition for Review by the United States Court of Appeals for the Ninth Circuit, of the decision of the Tax Court of the United States heretofore rendered in the above-entitled cause. A copy of the Petition for Review as filed is hereto attached and served upon you.

Dated at Portland, Oregon, this 13th day of December, 1956.

/s/ JAMES C. DEZENDORF,  
Counsel for Petitioner.

Affidavit of service by mail attached.

Received and filed December 18, 1956.

In the Tax Court of the United States

Docket No. 50695

AH PAH REDWOOD COMPANY,

Petitioner,

vs.

COMMISSIONER OF INTERNAL REVENUE,

Respondent.

Courtroom, U. S. Court of Appeals, U. S.  
Court House, Portland, Oregon

May 9, 1955, Monday

The above-entitled matter came on for hearing,  
pursuant to notice to the parties, at 10:09 o'clock  
a.m.

Before: Honorable Ernest H. Van Fossan,  
Judge Presiding.

Appearances:

MR. JAMES C. DEZENDORF,  
For the Petitioner.

MR. WENDELL M. BASYE,  
For the Respondent.

### PROCEEDINGS

The Clerk: Docket Number 50695, Ah Pah Red-  
wood Company.

Mr. Basye: Wendell M. Basye, for the Respondent.

Mr. Dezendorf: James C. Dezendorf, for the Petitioner.

The Clerk: How do you spell your last name?

Mr. Dezendorf: D-e-z-e-n-d-o-r-f.

The Court: What is the situation in this case?

Mr. Dezendorf: We are ready.

The Court: How long do you estimate that it would take to try the case?

Mr. Dezendorf: Not over a half a day, I wouldn't think; would you?

Mr. Basye: No; I wouldn't think so.

The Court: It will await assignment.

Mr. Basye: We would like to have the case assigned toward the end of the calendar, your Honor, on the basis that we haven't been approached at all on stipulation of facts of the case.

Mr. Dezendorf: That will be agreeable with us.

The Court: I will consider that.

(Whereupon, at 10:12 o'clock a.m., the hearing in the above-entitled matter was taken under consideration by the Court, and subsequently set for trial which was called for at 2:00 o'clock p.m., Tuesday, May 10, 1955.)

The Clerk: Docket Number 50695, Ah Pah Redwood [3\*] Company.

Would the attorneys please state their appearances?

---

\*Page numbering appearing at top of page of original Reporter's Transcript of Record.

Mr. Dezendorf: James C. Dezendorf, attorney for the Petitioner.

Mr. Basye: Wendell M. Basye, attorney for the Respondent.

The Clerk: William E.?

Mr. Basye: Wendell M.

The Clerk: Oh, Wendell M.

The Court: May I have your name again?

Mr. Dezendorf: Dezendorf—D-e-z-e-n-d-o-r-f.

The Court: Will you state the issues involved here?

Mr. Basye: Pursuant—if the Court please, pursuant to the provisions of Section 6861 of the Internal Revenue Code of 1954, the Respondent at this time asks leave to file with the Court, a Notice of Jeopardy Assessments, covering the deficiencies involved in this case.

The Court: That may be filed.

Mr. Dezendorf: If the Court please, the parties have entered into a stipulation which disposes of very many of the formal facts which Mr. Basye will present at the outset of his statement. There are only two basic questions involved in this proceeding, the first is whether the timber involved was disposed of within six months of the date of its acquisition, and the second is whether a proper completion basis or unit basis was applied to the timber that was [4] removed. We expect our evidence to show that the timber was not disposed within six months of the date of acquisition as is contended by the Government, because only an oral arrangement was in effect prior to the expiration of the six-month period,

and with respect to the completion basis, we expect to show that the Government's figures and the Petitioner's, too, were grossly inaccurate, because they were based upon a French cruise upon which the timber was purchased in the first place, which was compared with the timber that was sold and removed, and yet, while according to the French cruise, seventy million feet of timber should have remained when logging ceased, actually only thirty-seven million feet actually exists, so that there was approximately a fifty per cent fall-down in the cruise.

The Court: Mr. Basye, you may state the Government's position.

Mr. Basye: If the Court please, we feel that the issues as stated by the counsel for the Petitioner are not—we cannot quite narrow the case at the outset to those issues without further statement of facts. The position of the Government is, in accordance with the ninety-day letter, that the taxpayer, Petitioner in this case, was not entitled to treat sales of certain timber property or timber as a capital gain, and in view of the status of the petition filed by the taxpayer in this case, the assignment of errors in general, and the facts upon which the Petitioner relies are broad—very general—the allegations of error are broad, and until further facts can be submitted for the Court's consideration, we feel that the issues in the [5] case are first, did the Commissioner err in disallowing the capital gain treatment on the sales, and second, whether or not the cost or unit basis—or unit value of the timber was

in error. At this time, I would like to submit a stipulation of facts which the parties have agreed upon, together with Exhibit 1A, which purports to be an agreement between the Sage (phonetic) Land and Lumber Company, seller, and Union Bond and Trust Company, Exhibit 2B, which purports to be an agreement, between Ah Pah Redwood Company, as seller, and Coast Redwood Company as buyer.

The Court: The documents may be filed. They will be received.

Mr. Basye: The Respondent has no further statement of facts at this time.

The Court: You may proceed with the evidence.

Mr. Dezendorf: Mr. Adkins, will you step forward and be sworn, please?

J. J. ADKINS

a witness called on behalf of the Petitioner, first having been duly sworn, testified as follows:

The Clerk: Would you please state your name and address for the record?

The Witness: J. J. Adkins.

The Clerk: Is that A-d-k-i-n-s?

The Witness: Yes, mam.

The Court: What are the initials? [6]

The Witness: J. J.

Mr. Dezendorf: I wonder if I may have the exhibit that is on the table opposite the witness marked Petitioner's Exhibit 3?

The Court: What document is that?

Mr. Dezendorf: The map that is on the table, beside the witness.

(Testimony of J. J. Adkins.)

The Court: Hand it to the Clerk.

The Clerk: Maybe I had better go over there and mark it.

(Petitioner's Exhibit 3, witness Adkins, marked for identification.)

The Court: Is that marked for identification, Madam Clerk?

The Clerk: Identification.

The Court: Exhibit 3 for identification.

#### Direct Examination

By Mr. Dezendorf:

Q. Mr. Adkins, your name is J. J. Adkins?

A. Yes, sir.

Q. And where do you live, Mr. Adkins?

A. Beaver Creek, Oregon.

Q. Mr. Adkins, what, if any connection did you have with the Sage B timber which was owned by the Petitioner, Ah Pah Redwood Company in Northern California? [7]

A. I was general superintendent for the Company.

The Court: Speak a little louder, Mr. Witness.

A. I was general superintendent for the Company.

Q. As general superintendent, were the logging operations under your direction and control?

A. Yes, sir.



(Testimony of J. J. Adkins.)

Q. When did you undertake your duties in that capacity?

A. Well, I started working for the Company—I started in as superintendent for the Company in 1936.

Q. And when did you have anything to do with this timber in Northern California?

A. First started going down there in about '47, I believe.

Q. And did you have charge of the logging operations there from 1947 on?

A. I was just on the verge until 1949.

Q. And what did you assume—what position did you assume with respect to the timber in 1949?

A. Full charge of the whole operation.

Q. How long did that continue?

A. Until March of 1954.

Q. And by whom are you now employed, Mr. Adkins?

A. Myself.

Q. During the course of your operations in the Sage B Timber, did you become intimately familiar with the timber standing on it, and the line involved? [8]

A. Yes, sir.

Q. Have you had occasion to be on the grounds since March of 1954?

A. I was in there in November of 1954 and I was also in there in February of '55.

Q. Mr. Adkins, drawing your attention to the map on the table beside you which has been marked as "Petitioner's Exhibit 3," can you tell us what that is?

(Testimony of J. J. Adkins.)

A. That is a map of the operation, showing logged off land, the land that has timber standing on it, the land that has felled and bucked timber on it, and the land that has cold decks, or where it's cold decks.

Q. Now, does this map show all of the area which is comprised within the Sage B lands?

A. No; there was some land in twelve one, that is Township Twelve North and One East.

Q. And what is the status of the timber that was on the Twelve One East that you have just mentioned. Is that still standing, or is that— (Interrupted.)

A. No; that is all logged. That is the reason we—the map got so big we didn't use it.

Q. And the map which is Petitioner's Exhibit 3, shows all of the land on which there is any timber remaining, is that correct?      A. Yes, sir.

Q. Was that map prepared under your supervision and control?      A. Yes, sir. [9]

Q. Mr. Adkins, as of what date was—does that map speak, in other words, to what date has it been brought up to date?

A. That would be almost right up to date now. I would say within thirty days from now.

Q. When did logging operations on the area represented by the map cease?

A. In November of '54.

Q. And have there been any logging operations carried on since then?

A. No; no, there hasn't. There was some logging

(Testimony of J. J. Adkins.)

operations in there, but it involves something that isn't on there. With them two blank forties there.

Q. I see. We will offer the exhibit in evidence.

The Court: Any objection?

Mr. Basye: No objection.

The Court: It will be received, Exhibit No. 3.

(Petitioner's Exhibit 3, witness Adkins, received in evidence.)

Q. Now, Mr. Adkins, when the logging operations ceased in November of 1954, how much timber remained on the Sage B land according to the French cruise?

A. About seventy million or a little bit more.

Q. And at the same time, that is in November of 1954 when logging operations ceased, how much timber actually remained upon the ground? [10]

A. I don't think over about thirty-five, thirty-seven million.

Q. Mr. Adkins, when did you first suspect that there was a fall-down in the amount of timber being cut as compared with the French cruise?

A. Some time in the year of '52, and I don't remember just exactly what part of the year.

Q. When was it first possible to determine the actual amount of fall-down of the cruise, Mr. Adkins?

A. Not until he shut down last year, and they ran a complete line through there on the cutting boundaries.

Mr. Dezendorf: You may cross-examine.

(Testimony of J. J. Adkins.)

Cross-Examination

By Mr. Basye:

Q. Mr. Adkins, you stated that you were general superintendent for the company, I don't quite understand what company is involved—what company did you mean?

A. Coast Redwood Company and Union Bond and Trust Company.

Q. And it is with respect to those companies that you started your employment in 1936 I take it?

A. No; in 1936, Union Bond was in existence, but, of course, Coast Redwood wasn't. I don't remember. I believe that Coast Redwood was organized probably in about '45 or '46.

Q. You had no connection with the Ah Pah Redwood Company?

A. Yes; I did have to this extent, that I was in charge of the timber of this whole area of timber here, administering the logging of [11] it, looking after it, trying to get the line surveyed, and such things.

Q. Do you know of your own knowledge, Mr. Adkins, what agreement existed between Ah Pah Redwood Company and Coast Redwood Company, with respect to timber?

A. No; I wouldn't say that I could answer that question.

Q. Now, Mr. Adkins, with respect to the map that has been introduced in evidence as Petitioner's Exhibit 3. You state that you prepared the map?

(Testimony of J. J. Adkins.)

A. An engineer working for me did.

Q. Under your supervision?

A. That's right.

Q. And as I understand it, this map was kept cumulatively?

A. That's right.

Q. As timber was logged off of the tract, different markings were made upon the map?

A. Yes. And—— (Interrupted.)

Q. And—I'm sorry, go ahead.

A. Let me—now, the outside boundaries of that map are pretty accurate, but the inside boundaries—the survey on that was did by Sage, and it was pretty slow to get it surveyed, so we got the outside boundaries, so we didn't get on somebody else. The inside of it, you can't have it too accurate.

Q. Well, with respect to this map, it now shows the situation with respect to the timber as of November, 1954, is that correct?

A. That's right. [12]

Q. And that there were no other operations on the property after 1954?

A. That's right.

Q. Now, I believe you testified, Mr. Adkins, with respect to—it was your opinion that there was a certain amount of timber standing on the property on November, 1954, is that correct?

A. That's right.

Q. Would you tell me again how much timber was there, according to your opinion?

A. In my opinion?

Q. Yes, sir.

(Testimony of J. J. Adkins.)

A. About thirty-five or thirty-seven million.

Q. And you ascertained that at what time? When did you decide that there were thirty— (Interrupted.)

A. Say between November and February of this year.

Q. Of 1954 and 1955? A. Yes, sir.

Q. Now, Mr. Adkins, are you a cruiser?

A. Not a licensed cruiser; no.

Q. Did you make a scientific cruise to determine what timber was left on the property, or is this estimate with respect to what you kept on the map?

A. Yes, sir; I made a scientific—not only mine, but another man's opinion, because I was interested in buying the timber that was standing there. [13]

Q. And what was the basis for your determination?

A. I believe you will have to—I will have to have—I don't quite understand the question.

Q. I was wondering what you took into consideration in making your scientific estimate of the— (Interrupted.)

A. Oh, I see—I presume you are asking what quality timber and one thing another. Anything that I thought I could sell that was merchantable today.

Q. Have you ever been on the payroll of Ah Pah Redwood Company? A. No.

Q. Mr. Adkins, could sales be made of this timber by Ah Pah without your knowledge? In other words, if any timber was sold off of this particular tract by Ah Pah Redwood Company, would you nec-

(Testimony of J. J. Adkins.)

essarily have knowledge of it, because of your position with respect to Coast Redwood?

A. I think I would; yes.

Mr. Basye: No further questions.

Mr. Dezendorf: That's all, Mr. Adkins. Thank you.

(Witness excused.)

Mr. Dezendorf: Call Mr. Max Herndon.

JAMES M. HERNDON

a witness called on behalf of the Petitioner, first having been duly sworn, testified as follows:

The Clerk: Will you please state your name and address [14] for the record?

The Witness: James M. Herndon.

The Clerk: H-e-r-n-d-o-n?

The Witness: Yes, mam.

The Clerk: James M.?

The Witness: Right.

Mr. Dezendorf: May I have this marked as Petitioner's Exhibit 4, please?

The Clerk: Are you going to use that map over there any more?

Mr. Dezendorf: No.

The Clerk: I wonder if I may have it?

Mr. Dezendorf: Surely. (Map handed.)

The Clerk: Petitioner's Exhibit 4 for identification.

(Petitioner's Exhibit 4, witness Herndon, marked for identification.)

(Testimony of James M. Herndon.)

Direct Examination

By Mr. Dezendorf:

Q. Mr. Herndon, what is your business or occupation?      A. Certified Public Accountant.

Q. Speak up so we can all hear you.

A. Okay.

Q. And do you practice alone or with someone else?      A. I am a member of a firm.

Q. And what is the name of that firm? [15]

A. Yergen and Meyer.

Q. And where do you office in connection with your practice?      A. Head office is in Portland.

Q. And are you in charge of one of the branch offices?

A. Yes; I am in charge of the Medford Office.

Q. Mr. Herndon, I am showing you what has been marked as "Petitioner's Exhibit 4," and I will ask you to tell us what that is?

A. Well, this is a schedule of timber that has been either sold or removed from the Sage B Tract as prepared from the information that has been made available to me.

Q. Now, will you just explain that Exhibit to us a little fuller, Mr. Herndon, so that we will fully understand it, in connection with your testimony concerning it?

A. Well, in the years, originally this contract was contract between Union Bond and Trust Company and Sage Land and Lumber Company, and in



(Testimony of James M. Herndon.)

1946 and '47, there were certain amounts of timber severed—sixteen million feet and some odd—they were severed while the contract was owned by—wait a minute. The contract was owned by International Pacific Pulp and Paper Company, which had acquired it from Union Bond and Trust Company, and during 1946 and '47, while International Pacific Pulp and Paper Company owned the timber, they allowed Coast Redwood Company to sever sixteen and some odd million feet from the tract. Then, in, I think it is October of 1947, the timber was—and the contract were transferred to the Ah Pah Redwood [16] Company, which is a wholly owned subsidiary of International Pacific Pulp and Paper.

Mr. Basye: I object, your Honor, to the witness' answering those questions before he is properly qualified to show that he had knowledge of these various transactions that he is testifying to, on the grounds that so far, he has only stated that he was a public accountant, and certain information was furnished to him.

The Court: I think a little further qualification would be helpful.

Mr. Dezendorf: Well, if the Court please, all that he has mentioned so far are the facts that are included in the stipulation.

The Court: Proceed. We are not going to argue about it.

Q. Yes, sir. Mr. Herndon, relating now to the 1947 item by Ah Pah on the Exhibit, where did you procure the information which is there contained?

(Testimony of James M. Herndon.)

A. From this ledger I have on my lap.

Q. And the ledger that you have on your lap, is that the original ledger of Ah Pah Redwood Company?      A. That's right.

Q. And the other figures, the 1948 by Ah Pah on through to how far on the ledger which is before you?

A. Through June 30th of 1954. [17]

Q. Now, I call your attention to one item of eighteen million five hundred and seventy-five thousand, and the second one, where did you procure the information with respect to it?

A. One of those entries was in the ledger itself, and the other one was—came to light while we were having—during this examination.

Q. And that is included in the stipulation, is it not?      A. That's right.

Q. Now, Mr. Herndon, what does the figure total, one hundred and sixty-one thousand nine hundred and ninety-nine—one hundred and sixty-one million nine hundred and ninety-nine thousand four hundred and eighty-six represent in the middle of the Exhibit?

A. Well, that represents the total timber that was either sold or removed by cutting during the period from the original date of the contract, I guess, to—through November of 1954.

Q. Now, what—where did you get the information that is basis of the next portion of the Exhibit that you have prepared?

(Testimony of James M. Herndon.)

A. Well, I have here a copy of a contract which I think has already been filed with the Court. It is a copy of the Sage Land and Lumber agreement with Union Bond and Trust Company, and amended to that or appended to it, are some three pages of the forty-acre tracts that were in the Sage Land and Lumber Company contract. And on that schedule has been marked by Mr. Wilson, the portions that are still virgin timber, and the portions that are partially logged. And from those cruises, or footages by forty-acre tracts, I have added [18] those up and determined that there were fifty-eight million nine hundred and ninety-three thousand left per the French cruise, and then, in the—for want of better information, for—I had to estimate that the partially logged portions contained approximately fifty per cent, and that would be another eleven million six hundred and forty-four thousand or a total of seventy million six hundred and thirty-seven thousand feet of timber remaining according to the French cruise.

Q. Now, may I interrupt you there for a moment, Mr. Herndon, were you informed that fifty per cent of the forties which were partially—strike that. Were you informed that of the forty-acre plots which were partially logged off, that one-half of the timber remained?

A. No; there were quite a number of them, probably twenty or so, forty-acre tracts, and they were in various stages of cutting; some were almost entirely logged, some were almost entirely standing, so for—in order to develop some figures on this, we

(Testimony of James M. Herndon.)

used the fifty per cent average on the partially logged tract.

Q. Now, will you explain to us the figures and the items represented on the bottom part of the Exhibit?

A. Well, the total timber per the original contract for the original cruise was three hundred and eighty-two million feet, and some odd, and from that we deduct what we can determine as remaining per the French cruise, and we arrive at a total of three hundred and eleven million six hundred and ninety-six thousand feet that should have been logged or sold off of the tract. [19]

Q. And what, if anything, have you done further with respect to the actual amount of timber sold and removed from the property?

A. Well, by deducting the actual amount logged and sold, we arrive at a figure of a hundred and forty-nine thousand six hundred and ninety-six thousand five hundred and fourteen feet of timber that could be classed as fall-down. In other words, it was not in the—the cruises did not cut out by that amount of footage.

Q. And what percentage did that determine to be?

A. Forty-eight point oh three per cent.

Mr. Dezendorf: You may cross-examine. Oh, pardon me. I will offer the Exhibit Number 4.

Mr. Basye: No objection.

The Court: It will be received, Exhibit Number 4.

(Testimony of James M. Herndon.)

(Petitioner's Exhibit Number 4, witness Herndon, received in evidence.)

Mr. Dezendorf: You may cross-examine.

Cross-Examination

By Mr. Basye:

Q. Mr. Herndon, this Exhibit that has been submitted as Petitioner's Exhibit 4, was prepared by you, is that correct? A. That's correct.

Q. When was it so prepared?

A. It was last Saturday.

Q. The basis upon which this Exhibit—Petitioner's Exhibit 4 was prepared, was from information that you received, from, [20] I believe you testified, Mr. Wilson? A. A portion of it was.

Q. Will you please further identify Mr. Wilson for us?

A. That's Mr. A. K. Wilson, who is the President of the Ah Pah Redwood Company.

The Court: Didn't hear you.

A. Mr. A. K. Wilson, who is the President of the Ah Pah Redwood Company.

Q. Have you worked for Mr. A. K. Wilson in any other capacity other than by being employed by Ah Pah Redwood? A. Yes, sir, I have.

Q. Is Mr. Wilson the President of Coast Redwood Company? A. To my knowledge, he is.

Q. Is Mr. Wilson the President of Union Bond and Trust Company? A. He is.

(Testimony of James M. Herndon.)

Q. Is Mr. Wilson the President of International Pacific Pulp and Paper Company?

A. He is.

Q. Do you know who is the President of the A. K. Wilson Lumber Company?

A. Mr. Wilson.

Q. And do you know whether Mr. A. K. Wilson is a partner in the A. K. Wilson Timber Company?

A. He is. [21]

Mr. Basye: I have no further questions.

Mr. Dezendorf: No further questions.

The Court: You are excused.

(Witness excused.)

Mr. Dezendorf: Petitioners rest.

(Petitioners rest.)

The Court: Will you please tell me where they got the name "Ah Pah," what does that mean?

Mr. Dezendorf: Well, it is an Indian name. It doesn't really mean anything, but it is associated in that Northern California country there, and that is the reason the name was adopted for the name of the corporate vehicle to hold the timber.

The Court: Petitioner rests?

Mr. Dezendorf: Yes.

Mr. Basye: The Respondent would like to call Mr. Charles Carpenter.

CHARLES E. CARPENTER

a witness called on behalf of the Respondent, first having been duly sworn, testified as follows:

The Clerk: Will you please state your name and address for the record?

The Witness: Charles E. Carpenter, 1404 N. E. 58th, Portland.

Direct Examination

By Mr. Basye: [22]

Q. Will you tell the Court, Mr. Carpenter, your occupation? A. Internal Revenue Agent.

Q. In connection with your occupation, Mr. Carpenter, are you familiar with the income tax returns filed by Ah Pah Redwood Company, for the tax years 1948 and 1949?

A. I was at one time.

Q. What is the basis of your familiarity with them?

A. I made an examination of those returns.

Q. In connection with such examination, what did it entail, as far as work is concerned on your part?

A. Well, it took a considerable amount of work.

Q. What was the nature of that work?

A. Well, auditing of all of the records up to that period.

Q. These records included what, Mr. Carpenter?

A. Well, the general ledger, receipts and disbursements, and this examination details jointly with other affiliated companies, in order to reconcile the

(Testimony of Charles E. Carpenter.)

various organizations together was what took more of the detail and made work of this examination, as this—this Company standing alone, its records cannot be difficult to examine.

Q. Did this examination entail contacting for information or for conversation, any of the officers of Ah Pah Redwood Company?      A. It did.

Q. Which officers?

A. Mr. A. K. Wilson. [23]

Q. And he was the President of Ah Pah Redwood, is that right?      A. That's right.

Q. In connection with your examination, did you find, or was any information made available to you with respect to an alleged under-run of the timber property on Sage B timber tract?

Mr. Dezendorf: If the Court please, I would have to object to that question for the reason and upon the ground that it is based upon a finding—whatever he found would be the best evidence, and not his conclusion as to what it was. If it was based upon a conversation with Mr. Wilson, I think we are entitled to know where and when the conversation occurred.

Q. I will rephrase the question. In connection with your examination, Mr. Carpenter, did you make a report?      A. Yes.

Q. At the time you conducted your examination, you made notes and made a report?

A. That's right.

Q. Do you have in the courtroom a copy of your report?      A. I do.



(Testimony of Charles E. Carpenter.)

Q. I hand you herewith, what purports to be an Internal Revenue Agent's report, with respect to Ah Pah Redwood Company, the date of the original being January 12th, 1953, could you identify this report?

(Report handed.)

A. That is a copy of my original report, yes. A copy made by our office. [24]

The Court: I can't hear you.

A. A copy made by our office.

Q. And in preparing this report, did you make any reference to an alleged under-run in the Sage B Timber Tract, in question in this proceedings?

Mr. Dezendorf: If the Court please, I would object to that, for the reason and upon the ground that whether he made reference to it or not has no material bearing on any issue in this case. The fact might have been mentioned or discussed, not mentioned in his report; whatever is in his report, it speaks as the best evidence rather than his testimony concerning it.

The Court: He may answer.

Q. You may answer.

A. Could I have the question again, then?

Q. I believe I asked you whether you made reference in your report to any alleged under-run that had taken place on the Sage B Timber Tract?

A. Yes, in discussing with Mr. Wilson this case, Mr. Wilson agreed to all of the adjustments, but

(Testimony of Charles E. Carpenter.)

couldn't agree—couldn't sign what we call an eight seventy agreement form, because at that time, he said that he was—thought there would be a vast under-run in this tract of timber, and that he was not free to make any determination of that under-run at that time, but that when and if he could put the figures together to determine that, he was sure that it would prove on a tax basis that he should be entitled to an under-run, and [25] that would wipe out the other adjustments substantiating the tax liability.

Q. And you stated that this—that the time this report was prepared, the date was January 1st, 1953?

A. That's right.

Mr. Basye: You may inquire.

Mr. Dezendorf: No questions.

The Court: You are excused.

(Witness excused.)

Mr. Basye: The Respondent rests, your Honor.

(Respondent rests.)

The Court: Any rebuttal?

Mr. Dezendorf: No rebuttal.

The Court: How much time do you wish for briefs?

Mr. Basye: If the Court please, I would like to suggest sixty days for simultaneous briefs, sir.

Mr. Dezendorf: That would be agreeable.

The Court: Sixty days will be allowed for simultaneous briefs; thirty days thereafter for replies.

The case is closed.

(Whereupon, at 2:40 o'clock p.m., the hearing in the above-entitled petition was closed.)

Filed June 1, 1955, T.C.U.S. [26]

---

EXHIBIT No. 1-A

[Penciled in top margin]: This Copy was Typed by Al Carlson on Oct. 24, 1952.

Purchase Agreement

This Agreement entered into this 13th day of December, 1946, between Sage Land and Lumber Company, Inc., a corporation, organized under the laws of the State of New York, hereinafter called "Seller," and Union Bond & Trust Company, a corporation organized under the laws of the State of Oregon, hereinafter called "Buyer";

Witnesseth

Now, Therefore, in consideration of the premises and of the performance of the provisions of this Agreement, the parties hereto agree as follows:

1. Seller agrees to sell and Buyer agrees to purchase and take from Seller at the times and upon the conditions hereinafter set forth the lands situated in the County of Humboldt, State of California, described in Schedule "A" attached hereto and made a part hereof, said lands being described by tracts,

numbered separately in said Schedule. Said Schedule contains the estimated area of each separate tract and an estimate of the number of board feet of the redwood and Douglas fir timber contained therein, and except as otherwise provided in this Agreement, the area of such tract and the estimates of timber contained therein, as shown by said Schedule, shall, for all purposes herein, be conclusive and binding on the parties hereto.

2. The total purchase price is \$1,146,998.00, except as it may be modified by the provisions hereof.

3. The purchase price shall be paid in the following manner:

(a) \$50,000 on or before the execution of this Agreement. (Such \$50,000 has already been paid.)

(b) Minimum payments on July 1st of each year commencing with July 1st, 1947, to and including July 1, 1953, each of which minimum payments shall consist of \$100,000.00 in cash and a promissory note of Buyer payable to Seller or order, in the principal amount of \$56,714.00 payable July 1, 1954, with interest thereon at the rate of 4% per annum payable annually.

(c) In addition, Buyer shall pay Seller, prior to Buyer's removal of any timber from any numbered tract in Schedule "A" hereof, an amount equal to the total amount of M feet of redwood timber stated to be thereon in Schedule "A" hereof on the basis of \$3.00 per M feet, which such payment shall be credited against the next minimum cash payment

due under the provisions of paragraph 3 (b) hereof, and Buyer shall have no right to remove any timber from any tract described in Schedule "A" hereof unless Buyer has paid for said tract as provided in this paragraph.

(d) There is no balance as total of cash payments and notes is the purchase price.

The total purchase price to be paid hereunder shall not be reduced by reason of damage or destruction of any timber on the property sold hereunder which occurs subsequent to the date of this Agreement by reason of fire or other cause.

4. At any time prior to October 1, 1949, Buyer may select any tract or tracts described in Schedule "A" to be recruised. As such selections are made, but in no event later than October 1, 1949, Buyer shall name a cruiser and instruct him to proceed with the cruise. If the cruiser named by Buyer is acceptable to Seller, the total amount of redwood timber shown by such recruise shall be substituted in such tract or tracts for the amounts shown in Schedule "A" hereof and such substituted amount shall be final and be deemed thereafter to be actual amounts for all purposes of this Agreement. Such adjustment shall be made in the cash portion of the minimum annual payment next due. If the cruiser named by Buyer is not acceptable to Seller, Seller shall name a cruiser to make a joint cruise with Buyer's cruiser and the joint cruise shall then be final for all purposes herein. In the event the two cruisers cannot agree, they shall select a third

cruiser and the three cruisers shall make a joint cruise of all redwood timber then uncruised and the results thereof shall be final for all purposes herein.

5. Buyer stipulates that it has had access to the property of Seller covered by this Agreement, before the execution thereof, and that it is familiar with the land and topography thereof and the timber thereon and that the quality of said timber is fully known to it and that it is not making this Agreement by reason of any representation by Seller. It also stipulates that it shall not make any claim of any kind based on the quality or the kind thereof which it has the right to cut and remove under this Agreement, and Buyer likewise stipulates that it will not make any claim of any kind based upon the alleged shortage in the amount of timber which it has the right to cut and remove hereunder.

6. Seller shall have the right at all reasonable times, upon reasonable notice, to inspect the books and records and accounts of Buyer relating to its operations hereunder.

7. Seller agrees that in advance of Buyer logging on any of the property covered hereby, and, in any event prior to April 1, 1949, Seller will mark the exterior boundaries of the property covered hereby. Seller agrees that, without cost to Buyer, it will obtain right-of-ways for Buyer over and across the lands owned by Ward Redwood Company and Blue Creek Redwood Company in Humboldt and Del Norte Counties adjacent to or blocking access

to lands covered by this Agreement, and Seller shall obtain for Buyer the right to the use of any now existing roads on such lands owned by said two companies.

8. Whenever, and from time to time, lots or 40-acre pieces covered hereby have been paid for by Buyer pursuant to paragraph 3 (c) hereof, the Seller, upon request of Buyer, shall deliver to Buyer a grant deed covering such lots or 40-acre pieces. The minimum payments under paragraph 3 hereof shall not give Buyer credits under this paragraph.

9. When Buyer has paid the purchase price as provided in paragraph 3, Seller shall deliver to Buyer a grant deed to the property. Buyer may at any time pay the entire purchase price hereof, in which event the Seller, upon Buyer's request, will give Buyer a grant deed to the property covered hereby.

10. Whenever a deed is delivered to Buyer for any or all of the property covered hereby, Buyer agrees to pay Seller the taxes on such property so deeded, prorated to the date of such deed. Buyer shall pay any increase in taxes on any timber or logs covered hereby, which increase is the result of Buyer's operations hereunder.

11. This Agreement is subject to:

(a) An Agreement between Seller and California Barrel Company, Ltd., dated June 22, 1942, as amended by Agreements dated June 29, 1942, October 27, 1944, and October 31, 1944.

(b) An Agreement between Seller and Arrow Mill Company, dated June 15, 1943, as amended by Agreements dated April 26, 1944, and November 30, 1944, relating to Sections 11, 12, 13 and 14 of Township 12 North, Range 1 East, Humboldt Base, Meridian, Humboldt County.

(c) An Agreement between Seller and Arrow Mill Company, dated June 15, 1943, as amended by Agreements dated April 26, 1944, and November 30, 1944, relating to Section 7 of Township 12 North, Range 2 East, Humboldt Base and Meridian, Humboldt County.

(d) An Agreement between Seller and Arrow Mill Company, dated June 30, 1945, relating to Sections 8, 9, 15, 16, 17 and 18, Township 12 North, Range 2 East, Humboldt Base and Meridian, Humboldt County, all of the above agreements have been exhibited to and examined by Buyer.

(e) An Agreement between Seller and California Veneer Company dated October 4, 1944, relating to the South half of the Southeast quarter and the South half of the Southwest quarter of Section 13, the North half of the Northeast quarter and the North half of the Northwest quarter of Section 24, all in Township 12 North, Range 1 East, Humboldt Base and Meridian, Humboldt County, expiring November 10, 1947.

Seller warrants that there have been no extensions, modifications or changes in the terms of said Agreements other than above indicated. No exten-



sions, modifications or changes shall be made in said Agreements without the written approval of Buyer first had and obtained. All sums hereafter becoming due Seller under said Agreements for timber other than Douglas Fir and Spruce cut under the terms of said Agreements shall be credited to the next minimum payment becoming due.

Seller will, within ten days from receipt of written request from Buyer, give any notice which Seller has the right to give under the terms of any of said Agreements. If Seller fails to give such notice within the time prescribed, Buyer may either in its own name or the name of Seller give such notice.

In the event of failure to comply with the provisions of such notice within twenty days after the giving thereof, Buyer shall have the right in its name or in the name of Seller to enforce compliance with said notice and Agreements and take whatever action Seller would have the right to take under the terms of said Agreements, and to have credited upon the next minimum annual payment becoming due any money which may be due for damage to the property and timber purchased herein.

If Buyer gives such notice, it shall indemnify Seller in the event such notice is wrongfully given.

12. All operations conducted hereunder shall be conducted in accordance with all laws in force for fire prevention and control. Buyer agrees that good forestry practice shall be followed to the fullest possible extent.

13. Buyer agrees to do everything reasonably practical to protect the timber from fire, and in this regard:

(a) Buyer agrees to burn, under control and during favorable weather conditions, the slash and debris caused by its logging operations and thereby reduce the danger of fires getting beyond control and damaging standing timber.

(b) If Buyer uses steam donkey engines, Buyer agrees that all brush in the neighborhood of such engines shall be cleared to a sufficient distance to prevent any sparks or fire from the donkey engines setting fire to any neighborhood timber as provided by law.

(c) Buyer agrees to keep all logging camps and other structures used in connection with the operations hereunder, and the ground in their vicinity, in a clean, sanitary condition, and rubbish shall be removed and burned or buried and, when camps or other establishments are moved from one location to another, Buyer shall burn or otherwise effectively dispose of all debris and abandoned structures.

14. Buyer agrees to indemnify and save Seller harmless from any and all liability arising out of the cutting, felling, damaging or injuring of timber on property owned by a third party and arising from or relating to operations hereunder and from any and all liability of any kind or character whatsoever to third parties arising out of or relating to fires commenced or authorized to be commenced by

Buyer, its agents or licensees, or required by law or any public authority and connected with or relating to operations hereunder, and to indemnify and save harmless Seller from any and all liability of any kind or character whatsoever arising from or relating to the operations hereunder.

15. Buyer shall at all times observe and comply with, and cause its agents and employees to observe and comply with, all existing laws, ordinances and regulations pertaining to industrial accidents, public liability, Social Security, Fair Labor Standards Act, and Public Contract Act, as required by the laws of the State of California and the United States of America.

16. Any and all payments required to be made by Buyer hereunder, and all statements required hereunder, shall be delivered to Seller at its office at the Crocker Building, San Francisco, California, or at such other place as may from time to time be directed by Seller in writing.

17. Any notice to be given under this Agreement, or any communication to be made hereunder between the parties hereto shall be deemed to be given or made upon the deposit of the same in the United States mails by registered mail to be delivered to addressee only with postage thereon prepaid, duly addressed to the other party as follows:

Sage Land & Lumber Company, Inc.,  
Crocker Building,  
San Francisco, California;

Union Bond and Trust Co.,  
923 S.W. 5th Avenue,  
Portland, Oregon.

Either party shall have the right to give written notice to the other of a change in address, and after such written notification, such changed address shall be deemed for all purposes to be substituted in this Agreement for the address given above.

18. This Agreement shall be personal to Buyer and may not be assigned by Buyer without the written consent of Seller, except to A. K. Wilson or a Corporation controlled by A. K. Wilson, or his family. Upon such assignment or subsequent re-assignment and upon the assumption by the assignee of the Buyer's obligations herein contained, the assignor shall be relieved of the duty to perform such obligations. In the event of an assignment to a Corporation controlled by A. K. Wilson or his family, such assignment can be made only upon the written consent of Seller or, without such consent, if such Corporation has not less than \$100,000 paid in capital.

19. In the event that Buyer shall default in the payment of any sum of money required to be paid hereunder on any date whereon the same is due and payable, and such default shall continue for a period of 30 days, or in the event that Buyer shall default in any one or more of the provisions or Agreements herein contained other than for the payment of money, and such default shall continue for 30 days after notice thereof, then Seller may give to Buyer

30 days' notice of its intention to terminate this Agreement and thereupon, at the expiration of 30 days after receipt of such notice, this Agreement shall be void and of no effect and Buyer shall peaceably withdraw from said land and surrender the same to Seller, and Seller shall have and enjoy the said land as of its former estate, free and discharged of this Agreement, but Buyer shall nevertheless, remain liable to Seller as provided in paragraph 20 hereof. This covenant shall be deemed to run with the land, shall inure to the benefit of Seller, its successors or assigns, and shall bind Buyer and its Successors.

20. In the event that this contract shall be terminated because of the Buyer's default as provided for in paragraph 19, Buyer shall, nevertheless, remain liable to Seller pursuant to paragraph 14 hereof. It is agreed that all sums theretofore paid to Seller by Buyer shall be deemed liquidated damages for the breach of this Agreement, it being understood that it is impractical or extremely difficult, if not impossible, to ascertain the actual damage which Seller will sustain in the event of Buyer's default. In the event of such default and subsequent cancellations of this Agreement, the obligation of Buyer to make further payments shall cease.

21. Buyer shall be permitted to construct all roads desirable or necessary for the operations hereunder. Buyer shall have the right, upon request of Seller, to use any roads constructed upon lands of Seller constructed by others, providing access to the

property covered hereby, and Buyer agrees to pay its proportionate share of the maintenance and repair of such roads, in relation to its use thereof, provided that Buyer has first approved such expenditure in writing, and such approval will be given if such expenditures are reasonably necessary for the maintenance and repair of such roads.

22. If any dispute or disagreement shall arise in connection with the interpretation of this Agreement or the performance or non-performance thereof, or the existence or non-existence of any fact, and such dispute and disagreement shall not be settled in writing within 30 days after it shall have arisen, then it shall be settled by arbitration. One arbitrator shall be chosen by the party initiating arbitration, another arbitrator by the other party, and a third disinterested arbitrator by the first two arbitrators. The decision of the arbitrators shall be enforceable under the laws of the State of California.

Either party may initiate arbitration by giving the other written notice of its request for arbitration within 60 days after such dispute or disagreement has arisen, which notice shall state the matter to be arbitrated and the name and address of the arbitrator chosen by the party initiating arbitration. The party to whom such notice is given shall, within 30 days thereafter, choose its arbitrator and within said thirty days give written notice to the party initiating arbitration, stating the name and address of the second arbitrator. The two arbitrators so

chosen shall, within 30 days thereafter, select a third disinterested arbitrator. If the party requested to choose the second arbitrator fails to do so within the time specified, the arbitrator first appointed shall be sole arbitrator. In the event the two arbitrators do not select a third within 30 days after chosen, then the third shall be appointed by the judge of the Superior Court of the County in which the dispute arose. The party at fault shall pay the cost and expenses of the arbitration and if both parties are at fault, the expenses and cost of the arbitration shall be divided equally regardless of the extent of the fault of either party. If the arbitrators determine that neither party is at fault, the party initiating arbitration shall pay the cost and expense thereof.

Both parties shall have 30 days from and after receipt of notice of final determination of the controversy to perform this agreement in accordance with the award.

In any event, any award to be effective hereunder must be made within 120 days after notice of request for arbitration is given, unless the parties mutually agree to an extension.

23. In the event that Buyer is forced to suspend operations for more than thirty days by reason of fire, flood, strike, Acts of God, or other causes beyond its control, the provisions of this Agreement pertaining to minimum annual payments shall be suspended for the period of time that Buyer is unable to operate provided that no one extension shall be for more than six months and that there

shall be not more than a total of twelve months' suspension during the life of this Agreement. At any time Buyer's operations are suspended for more than thirty days, it shall immediately give Seller written notice thereof.

24. Time is of the essence of this Agreement.

25. The acceptance of Seller of one or more payments from Buyer after the date when such payment or payments becomes due shall not be considered or construed to be a waiver of the right of Seller to insist that any or all future payments be made within the time specified therefor and shall not be construed as a waiver of the right of the Seller to terminate this Agreement under paragraph 19 hereof, or a waiver of the provision that time is of the essence of this Agreement.

26. Seller reserves unto itself, its successors or assigns, right-of-way over the Ah Pah access road as now built and as hereafter built from the Redwood Highway to the Ah Pah Ranch at the mouth of Ah Pah Creek.

27. Seller reserves right-of-ways over property herein covered for two purposes as follows:

(a) To consummate reciprocal rights of way agreements with Ward Redwood Company and Blue Creek Redwood Company to permit access to property owned by Seller, Ward Redwood Company and Blue Creek Redwood Company, and

(b) To permit access to lands owned by Seller in the event this Agreement is terminated by reason of Buyer's default.



In the event of termination of this Agreement, Seller gives to Buyer right-of-ways over land owned by Seller to permit access to lands owned by Buyer.

28. Each and every provision of this Agreement shall inure to and be binding upon the successors and assigns of the Seller and the successors and assigns of the Buyer.

29. This Agreement supersedes all previous accompanying, contemporaneous or collateral agreements, options, stipulations, and understandings oral or written between the parties or their predecessors relating to the timber and property sold hereunder and is the only, and the entire agreement relating thereto between the parties hereto.

In Witness Whereof, the parties hereto have executed this Agreement as of the day and year first above written.

SAGE LAND & LUMBER COM-  
PANY, INC.,  
Seller,

/s/ E. O. HOLTER, JR.,  
President.

UNION BOND & TRUST COM-  
PANY,  
Buyer,

/s/ A. K. WILSON,  
President.

Duly verified.

## EXHIBIT No. 2-B

[Pencilled in top margin]: Extra copy with only part of page agreement attached.

## Agreement

This agreement made and entered into this 9th day of January, 1950, by and between Ah Pah Redwood Co., a California corporation, hereinafter called "Seller," and Coast Redwood Co., Incorporated, a California corporation, hereinafter called "Buyer."

## Witnesseth

Whereas, Seller has heretofore purchased the agreement dated December 13, 1946, between the Sage Land & Lumber Company, Inc., as Sellers, and the Union Bond & Trust Company, as Buyer and all rights thereunder, which agreement is known as the Sage "B" agreement, and Seller is now the full and complete owners thereof, and

Whereas, the Buyer has been logging in the district where the land covered by said agreement of December 13, 1946, is located, and have been logging the northwesterly part of the land covered by said agreement paying therefor \$5.00 per M. feet Board measure as stumpage for all the logs removed from said land as said logs have been removed, and

Whereas, the Seller hereunder has previously entered into two agreements with Walter Foster each for the sale of a part of the timber covered by said Sage "B" agreement, and

Whereas, the said two agreements entered into with Walter Foster which were later assigned to the Big Tree Timber Co., became in default and have been properly cancelled and terminated\* pursuant to the terms thereof, and

Whereas, it is desirable for the Seller to sell all of the land and timber being purchased under said Sage "B" agreement so as to receive stumpage payments therefor which will be of assistance in making the payments required to be made under said Sage "B" agreement, and also to liquidate their investment in said agreement, and

Whereas the Buyer is willing to enter into such an agreement and have sufficient logging equipment and facilities to successfully conduct such an undertaking, and

Whereas, the Buyer is operating a sawmill in the same County in which the timber is located, and

Whereas it appears to be to the best interest of those two corporations that this formal agreement be entered into.

Now, Therefore, in consideration of the premises and of the performance of the provisions of this agreement, the parties hereto agree as follows:

1. Seller agrees to sell and Buyer agrees to purchase and take from the Seller, at the times and upon the terms and conditions hereinafter set forth,

---

[\*Underscored material appeared as an alteration on the original—initialed by A. K. W. and M.E.W.]

all the land and timber covered by said Sage "B" agreement situated in the County of Humboldt, State of California, more particularly described in Schedule "A" attached hereto and made a part hereof.

2. Buyer agrees to pay \$5.00 per 1,000 feet B. M. Humboldt scale for such lands and timber and are hereby given the option to pay therefor either on the basis of \$5.00 per 1,000 feet B. M. Humboldt scale on a pay-as-cut basis as the timber is removed from the land and/or pay for said land and timber on a cruise basis, or on a combination of either of such basis. When the land and timber are to be paid for on a cruise basis the payment for each tract as shown on Schedule "A" hereof is to be paid for at the rate of \$5.00 per 1,000 feet Board Measure for what timber is shown by schedule "A" hereunto attached to be on such tract. In any event, whenever Seller is entitled under the terms of said Sage "B" agreement to receive any deed or deeds to any of the land covered by the Sage "B" agreement, such land shall be forthwith deeded to Buyer or their nominee. When the logging has been completed on certain tracts of the land covered by the Sage "B" agreement and the remainder of the tracts covered by said Sage "B" agreement have been paid for on a cruise basis to the end that the land has either all been logged or all of the tracts described in Schedule "A" of said Sage "B" contract shall have been paid for, the Buyer hereunder shall be entitled to and shall forthwith receive a deed to all of the land covered under the Sage "B" agreement.

Time is of the essence of this agreement and when the payments are made on a stumpage basis, said payments are to be made on the 10th day of each month for all logs removed during the preceding calendar month.

3. It is understood that should the Buyer find it convenient or expedient to sell some of the tracts described in Schedule "A" of said Sage "B" agreement to a third party, Seller will forthwith secure from Sage Land & Lumber Co., a deed to said tracts as listed in Schedule "A" that are paid for and forthwith deliver to buyer or their nominee, a deed to the tracts so paid for. Buyer may sell one or more of said tracts on a cruise basis either for cash or on terms and upon payment being received by Seller therefor at the rate of \$5.00 per M. feet Board Measure, a deed therefor is to be issued to buyer or their nominee.

4. It is understood and agreed that all the terms and provisions of the Sage "B" agreement in respect to logging, shall be complied with and that all work shall be done in a good and workmanlike manner in keeping with good logging practices.

5. This agreement shall inure to the benefit of the successors and assigns of both Seller and Buyer.

In Witness Whereof, the parties hereto have executed this agreement the day and year first above written.

[Seal]                      AH PAH REDWOOD CO.,

By /s/ A. K. WELSH,  
President;

By /s/ M. E. WILSON,  
Secretary.

[Seal] COAST REDWOOD CO.,  
INCORPORATED;

By /s/ A. K. WELSH,  
President;

By /s/ M. E. WILSON,  
Secretary.

---

[Title of Tax Court and Cause.]

### MOTION FOR REVISION

Comes now your Petitioner, Ah Pah Redwood Co., acting by and through its attorney of record, James C. Dezendorf, and moves the Court for revision of its decision filed on September 28, 1956, in the above-entitled matter. The motion is based upon the following grounds:

#### I.

The opinion filed by the Court contains the following language:

“Whether or not petitioner’s theory be valid, its application will not constitute a disposition of the issue framed in the pleadings. Thus to narrow the issue is to make the unwarranted assumption that the timber involved in the transaction at issue constituted a capital asset to petitioner at the time of such transaction, within the definition contained in section 117 (a) (1) of the Internal Revenue Code

of 1939, or property used in petitioner's trade or business within the meaning of section 117 (j) (1), supra. In this connection, respondent makes the point, which we feel to be well taken, that petitioner at no time engaged in any logging activities, but, rather, merely sold the Sage timber to others under arrangements whereby the vendees would do the logging; that these sales of timber were the only business activity entered into by petitioner; that it is thus to be considered as having been engaged in the trade or business of selling timber; and that the timber in dispute, whether or not it was standing, was held for sale to customers in the ordinary course of such business.

“The facts found on this record lead to the conclusion that petitioner was engaged in the trade or business of selling timber and that the timber in controversy was held for sale to customers in the ordinary course thereof. Petitioner does not deny the nature of its business activity and the purpose for which the Sage timber was held. Nor does it claim that the timber comes within the definition of section 117 (a) (1), supra. In fact, petitioner bases its entire case upon the applicability of section 117 (j), supra. In this connection, petitioner's position is summed up in its statement on brief that section 117 (j) ‘\* \* \* includes timber to which section 117 (k) (2) is applicable and allows capital gain treatment of income therefrom without regard to the nature of the taxpayer's business or the purpose for which the timber is held.’ [Emphasis supplied.]

“The view thus expressed is in direct conflict with the plain wording of the statute relied upon. Section 117 (j), by its own language, specifically excludes from its operation all property held for sale to customers in the ordinary course of business. This being true, the gains derived from the sale of the Sage timber, regardless of the time of such sale, would not qualify for capital gains treatment under either section 117 (a) (1) or section 117 (j).”

The facts contained in the record are based upon a stipulation entered into between the parties, and adopted by the Court as a part of its opinion, and the testimony of three witnesses at the hearing of the cause, together with four exhibits introduced by Petitioner. The record contains no evidence to support a finding that Petitioner was engaged in the trade or business of selling timber and that the timber in controversy in this proceeding was held primarily for sale to customers in the ordinary course of business.

The law, as set forth in 26 USCA § 7453 and Tax Court Rule 31 (a), provides that the rules of evidence applicable to trials without a jury in the United States District Court for the District of Columbia shall apply to proceedings before the Tax Court of the United States.

The Tax Court may not make a finding of fact, and rest thereon a conclusion of law, when no evidence to support that fact is in the record.

In 39 Am. Jur. 146 (New Trial § 138), it is said:



“Where a cause has been tried by the court, its decision or finding has the same effect as the verdict of a jury, and if contrary to or not sustained by the evidence, a new trial may be granted. The question to be resolved by the appellate court is whether the trial judge, as a reasonable individual, acting as trier of the facts, could have found from the evidence such a verdict.”

To the same effect see *Parsons v. Federal Realty Corp.*, 105 Fla. 105, 143 So. 912, 88 ALR 275.

Upon the grounds herein set forth and the authorities cited in support thereof, your Petitioner therefore respectfully moves this Court to reconsider and revise its decision previously filed by deleting from said opinion the language quoted herein.

II.

The record of the case fails to disclose that Regulation 29.117-7 was cited to the Court during the hearing held or in the briefs filed by the parties to this cause. During the years in question, that regulation read, in part, as follows:

“Reg. 111, Sec. 29.117-7. Gains and losses from involuntary conversions and from the sale or exchange of certain property used in the trade or business. \* \* \*”

Section 117 (j) provides that the recognized gains and losses

\* \* \*

“(c) From timber held for more than six months which is considered to have been sold under the provisions of section 117 (k) (2), and with respect to taxable years beginning after December 31, 1943, from timber owned or held under a contract right to cut for more than six months prior to the beginning of the taxable year which is considered to have been sold or exchanged under the provisions of section 117 (k) (1), regardless of whether such timber would be properly includible in the inventory of the taxpayer if on hand at the close of the taxable year or whether such timber was held by the taxpayer primarily for sale to customers in the ordinary course of his trade or business,

shall be treated as gains and losses from the sale or exchange of capital assets held for more than 6 months if the aggregate of such gains exceeds the aggregate of such losses. If the aggregate of such gains does not exceed the aggregate of such losses, such gains and losses shall not be treated as gains and losses from the sale or exchange of capital assets.” [Emphasis supplied.]

On January 6, 1953, the Commissioner of Internal Revenue caused a modification to be made in the above-cited regulation, to reflect amendments to section 117 (j), Internal Revenue Code of 1939, effected by the Internal Revenue Act of 1951. The statutory amendment broadened the term “trade or business” to include unharvested crops, certain livestock, and coal. No change was made in the statute with regard to timber. The regulation, as modified,

omitted the language above cited. However, there is no ground for belief, nor has the Commissioner of Internal Revenue ever indicated, any change in the interpretation of the law as set forth in the previous regulation, nor has he so contended in this case, save for an implied reference in Respondent's brief filed subsequent to the trial of this cause (Resp. Br., pp. 13, 14).

Petitioner relied upon the above-quoted announcement and unchanged policy in presenting its case to this Court, and it is upon this basis that Petitioner now respectfully moves the Court to revise its opinion by deleting from its opinion previously filed the language quoted in ground I hereof, and substituting therefor the following:

“Petitioner is entitled to capital gains treatment of income derived from the disposal of timber, under the provisions of section 117 (j) and section 117 (k) (2), without regard to the nature of Petitioner's business or the purpose for which the timber is held, provided Petitioner satisfies the requirements set forth in the statutes cited.”

Wherefore, Petitioner respectfully moves this Court for revision of its opinion filed September 28, 1956, in the following particulars:

1. Deleting therefrom the language set forth in ground I hereof;
2. Substituting therefor the language set forth in ground II hereof;

3. Granting such other and further revision of its opinion as to the Court shall seem just and proper.

An opportunity to present oral argument is requested.

/s/ JAMES C. DEZENDORF,  
Attorney for Petitioner.

Received and filed October 29, 1956, T.C.U.S.

Entered November 5, 1956.

Served November 5, 1956.

---

[Title of Tax Court and Cause.]

### ORDER ENLARGING TIME

For cause, it is

Ordered: That the time for filing the record on review and docketing the petition for review in the United States Court of Appeals for the Ninth Circuit is extended to March 18, 1957.

/s/ J. E. MURDOCH,  
Judge.

Dated: Washington, D. C., January 17, 1957.

Served January 18, 1957.

Entered January 18, 1957.

[Title of Tax Court and Cause.]

CERTIFICATE

I, Howard P. Locke, Clerk of the Tax Court of the United States, do hereby certify that the foregoing documents, 1 to 12, inclusive, constitute and are all of the original papers on file in my office as called for by the "Designation of Contents of Record on Review" (including exhibits 1-A and 2-B, a part of the stipulation of facts), (but excluding documents requested in item 10, no action beyond ordering of briefs having been taken) in the case before the Tax Court of the United States docketed at the above number and in which the petitioner in the Tax Court has initiated an appeal as above numbered and entitled, together with a true copy of the docket entries in said Tax Court case, as the same appear in the official docket book in my office.

In testimony whereof, I hereunto set my hand and affix the seal of the Tax Court of the United States, at Washington, in the District of Columbia, this 29th day of January, 1957.

/s/ HOWARD P. LOCKE,  
Clerk, Tax Court of the  
United States.

[Endorsed]: No. 15,434. United States Court of Appeals for the Ninth Circuit. Ah Pah Redwood Co., a Corporation, Petitioner, vs. Commissioner of Internal Revenue, Respondent. Transcript of Record. Petition to Review a Decision of the Tax Court of the United States.

Filed February 11, 1957.

/s/ PAUL P. O'BRIEN,  
Clerk of the United States Court of Appeals for the  
Ninth Circuit.

In the United States Court of Appeals  
for the Ninth Circuit

No. 15,434

AH PAH REDWOOD CO., a California Corporation,  
tion,

Appellant,

vs.

COMMISSIONER OF INTERNAL REVENUE,  
Respondent.

NOTICE OF APPEAL

Notice is hereby given that Ah Pah Redwood Co., Appellant above named, hereby appeals to the United States Court of Appeals for the Ninth Circuit from the findings and conclusions contained in the opinion of the Tax Court of the United States and the decision entered therein in this matter on September 28, 1956, and pursuant to Rule 29 of this Court has this day filed with the Clerk of the Tax Court of the United States a Petition for Review, a copy of which is attached hereto as Exhibit A.

/s/ JAMES C. DEZENDORF,  
Attorney for Appellant.

[Endorsed]: Filed December 15, 1956, U.S.C.A.

[Title of Court of Appeals and Cause.]

STATEMENT OF POINTS ON WHICH  
APPELLANT INTENDS TO RELY ON  
APPEAL

Points

The points on which Appellant Ah Pah Redwood Co. intends to rely on appeal are as follows:

I.

The Tax Court erred in its opinion, wherein it made the following statement:

“The facts found on this record lead to the conclusion that petitioner was engaged in the trade or business of selling timber and that the timber in controversy was held for sale to customers in the ordinary course thereof. \* \* \*”

Error is predicated on the ground that the record shows no stipulated fact or evidence upon which such a conclusion can be based.

II.

The Tax Court erred in its opinion, wherein it made the following statement:

“\* \* \* In this connection, petitioner’s position is summed up in its statement on brief that Section 117 (j) ‘\* \* \* includes timber to which Section 117 (k) (2) is applicable and allows capital gain treatment of income therefrom without regard to the nature of the taxpayer’s business or the purpose for which the timber is held.’ [Emphasis supplied.]

“The view thus expressed is in direct conflict with the plain wording of the statute relied



upon. Section 117 (j), by its own language, specifically excludes from its operation all property held for sale to customers in the ordinary course of business. This being true, the gains derived from the sale of the Sage timber, regardless of the time of such sale, would not qualify for capital gains treatment under either Section 117 (a) (1) or Section 117 (j).”

Error is based upon the long-established interpretation of 1939 IRC Sec. 117 (j), both by Congress and by the Commissioner of Internal Revenue, and based upon the regulations promulgated by the Commissioner of Internal Revenue and in effect during the years involved in this controversy.

### III.

The Tax Court erred in its opinion, wherein it stated:

“While there is no direct evidence of the precise terms of the oral cutting contract entered into between petitioner and Coast, such contract, for aught that is shown, looked immediately to the severance and removal of all timber standing upon the Sage Tract.”

The Court erred in its determination in that the so-called oral contract between Appellant Ah Pah Redwood Co. and Coast Redwood Co. is an oral license to enter and to cut timber, revocable at will, and does not constitute a disposal of timber under the terms of 1939 IRC Sec. 117 and the regulations promulgated thereunder until such time as the licensee actually cuts and removes the timber.

## IV.

The Tax Court erred in its opinion, wherein it stated:

“The evidence here affords us no basis for making any finding that petitioner at any time in the taxable years knew or even suspected that its prior estimate of standing timber was erroneous. Albeit such error was readily ascertainable, it was not in fact ascertained at any time within either of the taxable years. In our view, therefore, the revision sought by petitioner does not qualify under the statutory provision that the allowance ‘for subsequent taxable years shall be based upon such revised estimate.’ ”

The Court failed to distinguish between adjustment of the depletion unit in subsequent years and the revaluation of the property for determination of the depletion basis, because of misrepresentation, fraud or gross error. The contention of Appellant is based upon the theory that property must be revalued for basis purposes because of gross error, misrepresentation or fraud as provided in 1939 IRC Sec. 23 (m) and regulations promulgated thereunder.

Respectfully submitted,

KOERNER, YOUNG, McCOLLOCH & DEZENDORF,

/s/ JAMES C. DEZENDORF,

/s/ [Indistinguishable].

Duly verified.

[Endorsed]: Filed February 19, 1957, U.S.C.A.

No. 15434

In the

**United States Court of Appeals  
For the Ninth Circuit**

AH PAH REDWOOD CO., A California Corporation,  
*Petitioner,*

vs.

COMMISSIONER OF INTERNAL REVENUE,  
*Respondent.*

---

**APPELLANT'S BRIEF**

---

Petition to Review a Decision of the  
Tax Court of the United States

---

HONORABLE ERNEST H. VAN FOSSAN, Judge

---

KOERNER, YOUNG, McCOLLOCH & DEZENDORF  
JAMES C. DEZENDORF  
MARSHALL C. CHENEY, JR.

Eighth Floor, Pacific Bldg., Portland 4, Oregon  
*Attorneys for Petitioner, Ah Pah Redwood Co.*

CHARLES K. RICE,  
*Asst. U. S. Attorney General;*

LEE A. JACKSON,  
Attorney, Dept. of Justice  
Department of Justice  
Washington 25, D. C.

*Attorneys for Respondent, Commissioner of Internal Revenue*

---

**FILED**

MAY 31 1957

PAUL P. O'BRIEN, CLERK



## SUBJECT INDEX

	PAGE
Jurisdiction .....	1
Statement of the Case .....	2
Specifications of Error .....	5
Argument .....	6
I. The Tax Court erred in its finding that amounts received by appellant in 1948 and 1949 from Coast Redwood Co. for timber cut from the property of appellant are taxable as ordinary income .....	6
A. The record does not permit a finding that appellant was engaged in the trade or business of selling timber or that the timber in controversy was held primarily for sale to customers in the ordinary course thereof .....	6
B. The law (1939 IRC § 117(j) and regulations in effect during 1948 and 1949 require that appellant treat the amounts received as long term capital gains .....	11
C. The oral contract between appellant and Coast was not a disposal of timber on the date thereof under the then existing laws and regulations .....	24
II. The Tax Court erred in its determination that appellant's depletion allowance for the taxable years 1948 and 1949 is not adjustable to correctly reflect the units of timber standing on appellant's property during those years .....	30
A. The depletion allowance for 1948 and 1949 is adjustable because of gross error, misrepresentation or fraud .....	30
Conclusion .....	36
Appendix .....	39

## TABLE OF CASES

	PAGE
Anderson v. Moothart, 198 Or. 354, 256 P. 2d 257 (1953).....	28
Bomberger v. McKelvey, 35 Cal. 2d 607, 220 P. 2d 729 (1950)..	29
Broads v. Mead, 159 Cal. 765, 116 P. 46 (1911) .....	29
Commissioner of Internal Revenue v. Brown Shoe Company, 175 F. 2d 305 (8th Circ. 1949) Rev'd on other grounds, 339 US 583, 94 L. Ed. 1081, 70 S.Ct. 820 (1950) .....	9
District of Columbia v. Seven Up Washington, 214 F. 2d 197 (CA, D.C., 1954), cert. den. 347 U.S. 989, 98 L. Ed. 1123, 74 S. Ct. 851 (1954) .....	9
Estate of Tarrant, 38 Cal. 2d 42, 237 P. 2d 505, 28 ALR 2d 419 (1951) .....	8
Gullicksen v. Shadoan, 124 Mont. 56, 218 P. 2d 714 (1950).....	26
Joseph Milling Co. v. First Bank of Joseph, 109 Or. 1, 216 P. 560, 29 ALR 358 (1923) .....	8
George B. Markle, 17 T C 1593 (1952) .....	7
Nee v. Main Street Bank, 174 F. 2d 425 (8th Circ. 1949) Cert. Den. 338 U.S. 823, 94 L. Ed. 500, 70 S. Ct. 69 (1949).....	9
Parsons v. Federal Realty Corp., 105 Fla. 105, 143 So. 912, 88 ALR 275 (1931) .....	10
Rust-Owen Lbr. Co. v. Commissioner, 74 F. 2d 18 (7th Circ. 1934) .....	33
Seaside Improvement Co. v. Commissioner, 105 F. 2d 990 (2d Circ., 1939) .....	7
Sorenson v. Jacobson, 125 Mont. 148, 232 P. 2d 332, 26 ALR 2d 1186 (1951) .....	26
Springfield Plywood Corp., 15 T C 697 (1950) .....	24
Sheldon Tauber, 24 T C 179 (1955) .....	7
Weaver v. Henslee, 120 F. Sup. 707 (USDC, Md. Tenn., 1954)	7

## STATUTES AND OTHER AUTHORITIES

	PAGE
3 Am. Jur. 463, Appeal and Error § 899 .....	8
39 Am. Jur. 146, New Trial § 138 .....	10
33 Am. Jur. 398, Licenses § 91 .....	28
89 CJS 471, Trial § 638 .....	10
26 USCA § 631(b) .....	21, 37
26 USCA § 7453 .....	9, 39
26 USCA § 1231(b) .....	18
1939 IRC § 117(j)(1) .....	5, 11
1939 IRC § 117(k)(2) .....	11, 13, 24, 28, 29, 36
1939 IRC § 117(j)(1) (amended) .....	15
1939 IRC § 117(k)(2) (amended) .....	4, 15
1939 IRC § 23(m) .....	30
Reg. 111, § 29.117-7 .....	12
Reg. 111, § 29.117-8(b) .....	14, 18
Reg. 111, § 29.117-7 (revised) .....	16
Reg. 1.631-2(a) .....	21
Reg. 111, § 29.23(m)-22 .....	31
Proposed Reg. 1.1231-1 .....	19
Rev. Rule 57-90, 1957-10 IRB 17 .....	22, 37
Rule 52(a) Fed. Rules of Civ. Procedure .....	9, 39
Tax Court Rule 31(a) .....	9, 39
House of Representatives Report No. 1079, 78th Congress, February 4, 1944, 1944 CB 1059, 1068 .....	14, 41
Senate Report No. 627, 78th Congress, December 22, 1943, 1944 CB 993, 1015 .....	14, 40
Title 26 U. S. Code § 7481-7483 .....	2





No. 15434

In the  
**United States Court of Appeals**  
**For the Ninth Circuit**

---

AH PAH REDWOOD CO., A California Corporation, *Petitioner*,  
vs.  
COMMISSIONER OF INTERNAL REVENUE, *Respondent*.

---

**APPELLANT'S BRIEF**

---

Petition to Review a Decision of the  
Tax Court of the United States

---

HONORABLE ERNEST H. VAN FOSSAN, Judge

---

**JURISDICTION**

Appellant Ah Pah Redwood Co. is a corporation organized and existing under and by virtue of the laws of the State of California, with its principal office and place of business located in Portland, Oregon. Respondent determined deficiencies in income tax of appellant, and additions thereto, for the years 1948 and 1949, pursuant to Sec. 291(a) of the Internal Revenue Code of 1939. Appellant filed its petition with the Tax Court of the United States, and being aggrieved by the adverse decision rendered therein on October 28, 1956 (R 28),

filed its Petition for Review (R 29) with that Court on December 18, 1956.

Jurisdiction of this Court is based upon Title 26 US Code, Sec. 7481-7483.

### **STATEMENT OF THE CASE**

Appellant, upon its organization in October, 1947, purchased all right, title and interest of "the buyer" in timber and lands covered by a certain purchase agreement (R 17). The agreement, dated December 13, 1946, defines Sage Land and Lumber Co., Inc. as "the seller," and Union Bond & Trust Co. as "the buyer." The timber and land are located in Humboldt County, California. The purchase price paid by appellant to "the buyer" was \$1,443,838.99. Hereafter this timber will be referred to as the Sage timber (Ex. 1-A; R 57).

Shortly after the Sage timber was acquired, appellant entered into an oral or implied agreement with Coast Redwood Co. (hereafter referred to as Coast), whereby the latter was permitted to enter upon the property to cut timber, and agreed to pay for such timber at the rate of \$5.00 per thousand board feet as removed (R 18).

On January 9, 1950, appellant executed a formal written agreement with Coast, pursuant to which ap-

pellant sold all the then remaining Sage timber to Coast (Exhibit 2-B, R 72).

In the years 1948 and 1949, appellant reported profits on sales of timber to Coast as long-term capital gains (R 18). In so reporting this income, petitioner used a basis for depletion of \$3.941566 per thousand board feet (R 18). Respondent also used such basis in computing a portion of the deficiencies here in question. Both parties computed the basis for depletion by dividing the amount of timber on the Sage Tract, as shown on Schedule A of the Sage Agreement per the French cruise (Ex. 1-A, R 57), which amount appellant assumed to be the correct quantity thereof, into the total purchase price paid by appellant for such timber (R 18). In 1952, appellant first realized that Schedule A of the Sage Agreement erroneously overstated the quantity of timber on the Sage Tract by a substantial amount. When appellant made an actual cruise shortly after logging operations ceased in November of 1954, the overstatement was found to be approximately double the actual amount of timber on the property, or a "fall-down" of approximately 48 per cent (R 19).

In addition to other sales, appellant sold 33,883,000 board feet of timber covered by the Sage Agreement to A. K. Wilson Lumber Co. in 1950. This quantity of timber was assumed to be the above amount on the

basis of the quantities shown in Schedule A to the Sage Agreement. Prior to appellant's acquisition of the Sage Agreement, International Pacific Pulp & Paper Co. sold 16,022,060 board feet of the timber covered thereby to Coast in the years 1946 and 1947 (R 19).

On June 18, 1953, respondent issued its 90 day letter to appellant, listing deficiencies in the following amounts:

<i>Year</i>	<i>Deficiency</i>	<i>Addition to Tax</i>
1948	\$ 2,654.84	\$ 663.71
1949	35,649.37	8,912.35

Respondent's deficiencies are based upon the theory that amounts received by appellant from Coast for timber cut and removed by Coast during the years in question were ordinary income rather than long term capital gain, since the oral or implied agreement of the fall of 1947 constituted a "disposal" of the timber under the provisions of 1939 IRC Sec. 117 (k) (2).

Appellant duly filed its petition with the Tax Court of the United States on September 16, 1953, protesting the deficiencies issued by the Commissioner (R 3). In that petition, appellant also sought adjustment of its basis for depletion allowance for the years in question because of the "underrun" of approximately 48 per cent of the timber originally estimated to be upon the Sage Tract.

On May 9 and 10, 1955, trial was had before the Tax Court of the United States, and on September 28, 1956, the Tax Court filed its opinion (R 16-28). A decision was entered on Sunday, October 28, 1956 (R 28), and on Monday, October 29, 1956, appellant filed a Motion for Revision with the Tax Court of the United States (R 76). No action having been taken thereon, on December 18, 1956, appellant filed with the Tax Court its Petition for Review of the case by this tribunal (R 29).

### **SPECIFICATIONS OF ERROR**

I. The Tax Court erred in its finding that amounts received by appellant in 1948 and 1949 from Coast for timber cut from the property of appellant are taxable as ordinary income.

- A. The record does not permit a finding that appellant was engaged in the trade or business of selling timber or that the timber in controversy was held primarily for sale to customers in the ordinary course thereof.
- B. The law (1939 IRC §117(j)) and regulations in effect during 1948 and 1949 require that appellant treat the amounts received as long term capital gains.

C. The oral contract between appellant and Coast was not a "disposal" of timber on the date thereof under the then existing laws and regulations.

II. The Tax Court erred in its determination that appellant's depletion allowance for the taxable years 1948 and 1949 is not adjustable to correctly reflect the units of timber standing on appellant's property during those years.

A. The depletion allowance for 1948 and 1949 is adjustable because of gross error, misrepresentation or fraud.

## ARGUMENT

### I.

THE TAX COURT ERRED IN ITS FINDING THAT AMOUNTS RECEIVED BY APPELLANT IN 1948 AND 1949 FROM COAST FOR TIMBER CUT FROM THE PROPERTY OF APPELLANT ARE TAXABLE AS ORDINARY INCOME.

**A. The record does not permit a finding that appellant was engaged in the trade or business of selling timber, or that the timber in controversy was held primarily for sale to customers in the ordinary course thereof.**

The record of this case shows nothing relating to the trade or business of appellant. The only business

transactions referred to are those dealing with the Sage timber. The nature of appellant's business has never been raised by the Commissioner.

Although a presumption arises in the Tax Court in favor of action taken by the Commissioner in assessing taxes, such a presumption does not and cannot arise with respect to contentions never raised by the Commissioner at any time prior to or during trial.

The presumption of correctness of the Commissioner's determination does not apply where he abandons the theory of his deficiency notice and seeks an increased deficiency on a different ground. *Seaside Improvement Co. v. Commissioner*, 105 F. 2d 990 (2d Circ, 1939); *Sheldon Tauber*, 24 TC 179 (1955).

Where the Commissioner changes the theory upon which he bases the deficiency subsequent to issuing the assessment notice, there is no presumption in favor of the Commissioner, and he must carry the burden of proof. *George B. Markle*, 17 TC 1593 (1952).

In *Weaver v. Henslee*, 120 F. Supp. 707, at page 710 (USDC, MD, Tenn., 1954), the Court said:

“Property is not held for sale to customers unless the taxpayer has customers and holds the property for the purpose of selling it to those customers rather than for some other purpose, such as to receive income from the property, or for a rise in the mar-

ket value of the property or for use in his own business. *Houston Deepwater Land Co. v. Scofield*, D.C., 110 F. Supp. 394; *Williamson v. Bowers*, D.C.S.C., 120 F. Supp. 704; *Kemon*, 16 TC 1026; *Latimer-Looney Chevrolet, Inc.*, 19 TC 120.”

Conclusions of law cannot be based upon findings of fact not supported by the evidence. 3 Am. Jur. 463 (Appeal & Error, § 899).

In *Estate of Tarrant*, 38 Cal. 2d 42, 237 P. 2d 505, at page 509, 28 ALR 2d 419 (1951), the Court, in speaking of findings made by the trial court, said:

“\* \* \* While it is true that ‘the findings of the trial court will not be disturbed on appeal if the record discloses substantial evidence to support them’, as was the case in *California Employment Commission v. Bethesda Foundation*, 54 Cal. App. 2d 348, 350, 129 P. 2d 874, 876, where the issue involved was the charitable status of the corporation in question, such rule has no pertinency where the evidence without conflict clearly establishes the impropriety of the inferences drawn by the court from the uncontroverted facts.”

In *Joseph Milling Co. v. First Bank of Joseph*, 109 Or. 1, at page 7, 216 Pac. 560, 29 ALR 358 (1923), the court said:

“Of course, if the record is devoid of any evidence to support an essential fact, a judgment can-



not be permitted to stand (*Tillamook County Bank v. International Lumber Co.*, 106 Or. 339, 211 Pac. 183); \* \* \*

The law, as set forth in 26 USCA § 7453<sub>1</sub>, and Tax Court Rule 31 (a)<sub>2</sub>, provides that the rules of evidence applicable to trials without a jury in the United States District Court for the District of Columbia shall apply to proceedings before the Tax Court of the United States.

The Tax Court may not make a finding of fact, and rest thereon a conclusion of law, when no evidence to support that fact is in the record.

Rule 52 (a) of the Federal Rules of Civil Procedure<sub>3</sub> applies to cases tried before the Tax Court. *Commissioner of Internal Revenue v. Brown Shoe Co.*, 175 F. 2d 305 (8th Circ., 1949) reversed on other grounds, 339 US 583, 94 L. Ed 1081, 70 S. Ct. 820 (1950).

Findings of fact not substantiated by the record are subject to attack on appeal. *Nee v. Main Street Bank*, 174 F. 2d 425 (8th Circ., 1949) cert. den. 338 US 823, 70 S. Ct. 69, 94 L. Ed. 500 (1949); *District of Columbia v. Seven Up Washington*, 214 F. 2d 197 (C.A.D.C., 1954) cert. den. 347 US 989, 98 L. Ed. 1123, 74 S. Ct. 851 (1954).

Numbered Footnotes refer to Appendix.

In 39 Am. Jur. 146 (New Trial § 138), it is said:

“Where a cause has been tried by the court, its decision or finding has the same effect as the verdict of a jury, and if contrary to or not sustained by the evidence, a new trial may be granted. The question to be resolved by the appellate court is whether the trial judge, as a reasonable individual, acting as trier of the facts, could have found from the evidence such a verdict.”

To the same effect see *Parsons v. Federal Realty Corp.*, 105 Fla. 105, 143 So. 912, 88 ALR 275 (1931).

In 89 CJS 471 (Trial § 638) it is said:

“In general, the amendment or correction of findings of fact and conclusions of law by the trial court rests in its sound discretion. Hence, while the trial court may properly amend or correct its findings of fact and conclusions of law where the evidence is sufficient to support the amendment made, and should amend them as far as necessary to make them conform to the facts admitted, provided the nonconformity is material, or where they fail to follow the evidence and do not speak the truth to the detriment of the party complaining, *generally speaking, it is required to amend or strike them only when they are not supported by the evidence or are outside the issues litigated.*” (Emphasis supplied)

Here, there is no basis whatever to support a finding regarding the nature of the business engaged in

by appellant. Nothing in the record indicates that appellant was or is engaged primarily in the sale of timber to customers in the ordinary course of its business. The nature of appellant's business and its purpose in holding the timber was never in issue, and no evidence was presented with respect thereto.

The finding of the Tax Court that appellant held the Sage timber primarily for sale to customers in the ordinary course of business is without foundation in the record. Such finding cannot be permitted to stand. Appellant is entitled to reversal of the decision of the Tax Court, insofar as it was based upon such finding.

**B. The law (1939 IRC Sec. 117(j)) and regulations in effect during 1948 and 1949 require that appellant treat the amounts received as long-term capital gains.**

The statutory language pertaining to the tax treatment of the disposal of timber is clear. 1939 IRC §117 (j) (1) reads in part as follows:

*“Such term (‘property used in the trade or business’) also includes timber with respect to which subsection (k) (1) or (2) is applicable.”* (Emphasis supplied)

The language of 1939 IRC § 117(j) (1) and § 117 (k) (2) must be interpreted to carry out Congressional

intent. When that intent is determined, it controls the meaning of the statutory language. The best source of knowledge of Congressional intent is found in pronouncements of persons and the responsible agency who had contact with Congress at the time of the enactment of the statute.

The language contained in the regulations promulgated by the Commissioner of Internal Revenue in 1944, shortly after the above statute was enacted, and in effect during 1948 and 1949, is explicit. It sets forth in plain, concise words the intended meaning of the statute.

Reg. 111, § 29.117-7 reads in part as follows:

*“Gains and losses from involuntary conversions and from the sale or exchange of certain property used in the trade or business. Section 117 (j) provides that the recognized gains and losses*

\* \* \* \* \*

*“(c) From timber held for more than six months which is considered to have been sold under the provisions of section 117(k) (2), and with respect to taxable years beginning after December 31, 1943, from timber owned or held under a contract right to cut for more than six months prior to the beginning of the taxable year which is considered to have been sold or exchanged under the provisions of section 117 (k) (1), regardless of whether such timber would be properly includible in the inventory of the taxpayer if on hand at the close of the taxable year or whether such timber was held by the*

*taxpayer primarily for sale to customers in the ordinary course of his trade or business,*

“shall be treated as gains and losses from the sale or exchange of capital assets held for more than 6 months if the aggregate of such gains exceeds the aggregate of such losses. If the aggregate of such gains does not exceed the aggregate of such losses, such gains and losses shall not be treated as gains and losses from the sale or exchange of capital assets.

\* \* \* \* \*

“Section 117 (j) does not apply to gains and losses on the sale, exchange, or involuntary conversion of any property which would properly be includible in the inventory of the taxpayer if on hand at the close of the taxable year or which is held by the taxpayer primarily for sale to customers in the ordinary course of his trade or business, \* \* \* but not including as such property timber which is considered to have been sold or exchanged as provided in section 117 (k) (1) or which has been sold as provided in section 117 (k) (2) \* \* \*.”  
(Emphasis supplied)

The provisions of 1939 IRC § 117 (k) (2) in effect during the years in question are as follows:

“(2) In the case of the disposal of timber (held for more than six months prior to such disposal) by the owner thereof under any form or type of contract by virtue of which the owner retains an economic interest in such timber, the difference between the amount received for such timber and the adjusted depletion basis thereof shall be considered as though it were a gain or loss, as the case may be, upon the sale of such timber.”

The language of the regulation then in effect is specific. Reg. 111, § 29.117—8 (b) provides as follows:

“If the taxpayer owned the timber for a period of more than six months prior to the date of such contract, for the purposes of section 117 (j) such timber shall be considered to be property used in the trade or business for the taxable year for which it is considered to have been sold, along with other property of the taxpayer used in the trade or business as defined in section 117 (j) (1). Whether gain or loss resulting from the disposition of the timber which is considered to have been sold will be deemed to be gain or loss resulting from the sale of a capital asset held for more than six months will depend upon the application of section 117 (j) in the case of the taxpayer.”

The language of the statutes and regulations in effect during 1948 and 1949 clearly establishes the rule that timber is to be considered a capital asset used in trade or business, even though it may be held primarily for sale to customers in the ordinary course of trade or business.

The interpretation placed upon the statutes by the regulations issued in 1944 effectively declares and carries out the intent of Congress. Also, see Senate Report No. 627, 78th Congress, December 22, 1943, 1944 CB 993, 1015<sub>4</sub>; House of Representatives Report No. 1079, 78th Congress, February 4, 1944, 1944 CB 1059, 1068<sub>5</sub>.

In 1951, Congress amended § 117 (j) (1) and § 117 (k) (2) of the Internal Revenue Code of 1939. However, these amendments did not in any way change the above quoted sections as they apply to timber. As amended, the sections read in part as follows:

*“(j) Gains and Losses From Involuntary Conversion and From the Sale or Exchange of Certain Property used in the Trade or Business.*

*“(1) Definition of property used in the trade or business. \* \* \* Such term (‘property used in the trade or business’) also includes timber or coal with respect to which subsection (k) (1) or (2) is applicable and unharvested crops to which paragraph (3) is applicable.”*

*“(k) Gain or Loss in the Case of Timber or Coal.*

\* \* \* \* \*

*“(2) In the case of the disposal of timber or coal (including lignite), held for more than 6 months prior to such disposal, by the owner thereof under any form or type of contract by virtue of which the owner retains an economic interest in such timber or coal, the difference between the amount received for such timber or coal and the adjusted depletion basis thereof shall be considered as though it were a gain or loss, as the case may be, upon the sale of such timber or coal.”*

In 1953, the Commissioner of Internal Revenue issued new regulations to implement the statutory amendments of 1951. Although these regulations de-

leted certain references regarding timber held primarily for sale to customers in the ordinary course of business, they still recognized the intent of Congress in the original enactment of these statutes and the correct interpretation of them reflected by the regulations issued by the Commissioner in 1944.

Reg. 111, § 29.117-7, as revised, provides in part as follows:

*“Gains and Losses from Involuntary Conversions and from the Sale or Exchange of Certain Property used in the Trade or Business.”*

(a) *in general*—(1) Section 117 (j) provides that the recognized gains and losses described below shall be treated as gains and losses from the sale or exchange of capital assets held for more than six months if the aggregate of such gains exceeds the aggregate of such losses. If the aggregate of such gains does not exceed the aggregate of such losses, such gains and losses shall not be treated as gains and losses from the sale or exchange of capital assets. The gains and losses referred to above are the following:

“(i) Gains and losses from the sale, exchange, or involuntary conversion of ‘section 117 (j) property’, as defined below, held for more than six months.

“(ii) Gains and losses from the involuntary conversion of capital assets held for more than six months.

“(iii) Gains and losses upon cutting or disposal of timber, or disposal of coal, to the extent provided in section 29.117-8.



“(iv) Gains and losses from the sale, exchange, or involuntary conversion of livestock, regardless of age, held by the taxpayer for draft, breeding, or dairy purposes, and held by him for more than six months from the date of acquisition (twelve months or more from the date of acquisition in the case of a taxable year beginning after December 31, 1950). (See (c) below.)

“(v) Gains and losses from the sale, exchange, or involuntary conversion in a taxable year beginning after December 31, 1950, of an unharvested crop under the conditions specified in (d) hereof.

\* \* \* \* \*

“(3) For the purpose of this section, the term ‘section 117 (j) property’ means property used in the trade or business of the taxpayer at the time of its sale, exchange, or involuntary conversion, which is of a character subject to the allowance for depreciation provided in section 23 (1) or which is real property, except any such property which is within one of the following categories:

“(i) Property of a kind which would properly be includible in the inventory of the taxpayer if on hand at the close of the taxable year, or which is held by the taxpayer primarily for sale to customers in the ordinary course of trade or business.

“(ii) In the case of taxable years beginning after September 23, 1950, a copyright, a literary, musical, or artistic composition, or similar property, held by a taxpayer described in section 117 (a) (1) (C).

“(iii) Livestock held for draft, breeding, or dairy purposes. (See, however, (1) (iv) above.)

“(iv) In the case of a taxable year beginning after December 31, 1950, poultry.”

The provisions defining “section 117 (j) property” relate *only* to the term as used in subparagraph (a) (1) (i) of the regulation, and that term is used only in a separate subparagraph from the subparagraph referring to timber. Thus, the subparagraph referring to “section 117 (j) property” has no application to the subparagraph relating to timber. This is borne out by the language of Reg. 111, § 29.117-8 (b), as it pertains to timber, which was unchanged when the revised regulations were issued.

The enactment of the 1954 Revenue Code further clarified the law, as it had always been understood, by placing timber and coal in a separate subsection in defining “property used in trade or business.” The general rule regarding property used in trade or business, containing the exceptions regarding inventories and property held primarily for sale to customers, is in a separate subsection of equal standing. It is apparent from this separation, previously accomplished by separate sentences in the same subparagraph, that Congress intended to completely clarify the rule that timber and coal should not be subject to the exceptions applicable to other types of property covered by the general rule in determining what constitutes “property used in trade or business.” 26 USCA § 1231 (b) provides as follows:

*“Definition of Property Used in the Trade or Business.—*For purposes of this section—

“(1) *General Rule*—The term ‘property used in the trade or business’ means property used in the trade or business, of a character which is subject to the allowance for depreciation provided in section 167, held for more than 6 months, and real property used in the trade or business, held for more than 6 months, which is not—

“(A) property of a kind which would properly be includible in the inventory of the taxpayer if on hand at the close of the taxable year,

“(B) property held by the taxpayer primarily for sale to customers in the ordinary course of his trade or business, or

“(C) a copyright, a literary, musical, or artistic composition, or similar property, held by a taxpayer described in paragraph (3) of section 1221.

“(2) *Timber or Coal.* Such term includes timber and coal with respect to which section 631 applies.”

This same clarification is carried out in the proposed regulations issued on July 18, 1956. Proposed Reg. 1.1231-1 provides in part as follows:

“Capital assets subject to section 1231 treatment include only capital assets involuntarily converted. The noncapital assets subject to section 1231 treatment are (1) depreciable business property and business real property held for more than 6 months, other than stock in trade and certain copyrights and artistic property; (2) timber and coal, if disposed

of in a manner coming within the provisions of section 631; and (3) certain livestock and unharvested crops. See paragraph (c) of this section.

\* \* \* \* \*

“(c) *Transactions to which section applies.*

“Section 1231 applies to recognized gains and losses from the following:

“(1) The sale, exchange, or involuntary conversion of property held for more than 6 months and used in the taxpayer’s trade or business, which is either real property or is of a character subject to the allowance for depreciation under Section 167 (even though fully depreciated), and which is not—

“(i) Property of a kind which would properly be includible in the inventory of the taxpayer if on hand at the close of the taxable year, or property held by the taxpayer primarily for sale to customers in the ordinary course of business;

“(ii) A copyright, a literary, musical, or artistic composition, or similar property, held by a taxpayer described in section 1221 (3); or

“(iii) Livestock held for draft, breeding, or dairy purposes, except to the extent included under subparagraph (4), or poultry.

“(2) The involuntary conversion of capital assets held for more than 6 months.

“(3) *The cutting or disposal of timber, or the disposal of coal, to the extent considered arising from a sale or exchange by reason of the provisions of section 631 and the regulations thereunder.*

“(4) The sale, exchange, or involuntary conversion of livestock if the requirements of § 1.1231-2 are met.

“(5) The sale, exchange, or involuntary conversion of unharvested crops on land which is (i) used in the taxpayer’s trade or business and held for more than 6 months, and (ii) sold or exchanged at the same time and to the same person. See paragraph (f) of this section.

“For purposes of section 1231, the phrase ‘property used in the trade or business’ means property described in this paragraph (other than property described in subparagraph (2) ).” (Emphasis supplied)

26 USCA § 631 (b) is a re-enactment of 1939 IRC § 117 (k) (2), with the added provision that the date of disposal of the timber shall be deemed to be the date such timber is cut.

Proposed regulations published on November 2, 1956, make even clearer provision for the capital gains treatment to be afforded timber. Reg. 1.631-2 (a) provides as follows:

“(a) *In general.* (1) If an owner disposes of timber held for more than six months before such disposal, under any form or type of contract whereby he retains an economic interest in such timber, the disposal shall be considered to be a sale of such timber. The difference between the amounts realized from disposal of such timber in any taxable year and the adjusted basis for depletion thereof shall be considered to be a gain or loss upon the sale of such timber for such year.

“Such adjusted basis shall be computed in the same manner as provided in section 611 and the regulations thereunder with respect to the allowance for depletion. See paragraph (e) (2) of this section for definition of ‘owner’.

“(2) In the case of such a disposal, the provisions of section 1231 apply and such timber shall be considered to be property used in the trade or business for the taxable year in which it is considered to have been sold, along with other property of the taxpayer used in the trade or business as defined in section 1231 (b).”

Throughout the entire history of these statutes, there has been no deviation from the clearly manifested intent of Congress that owners of timber are entitled to capital gains treatment of profits realized on sales made by them under cutting contracts wherein the owner retains an economic interest, *regardless* of whether the timber is held primarily for sale to customers in the ordinary course of business, provided the six-months holding period is satisfied.

Because of the opinion rendered in this case by the Tax Court of the United States, the Internal Revenue Service, on March 11, 1957, issued Revenue Ruling 57-90, 1957-10 I.R.B. 17, which reads:

“Section 631—*Gain or Loss in the Case of Timber or coal.*

“In the case of the disposal of timber, held for more than six months prior to such disposal, by the owner thereof under any form or type of contract by virtue of which the owner retains an economic interest in such timber, pursuant to the provisions of section 631 (b) of the Internal Revenue Code of 1954, *the gain or loss on such disposal is subject to the tax treatment provided by section 1231 regardless of the nature of the taxpayer’s business or the purpose for which the timber is held.* To the extent that the opinion in *Ah Pah Redwood Co. v. Commissioner*, 26 TC 1197, may be inconsistent with the foregoing, it does not represent the position of the Internal Revenue Service.” (Emphasis supplied)

The Tax Court’s opinion in the present case constitutes a direct contradiction of the manifest intent of Congress as expressed continually in the law itself. In addition, it directly contravenes the published regulations and rulings of the Commissioner of Internal Revenue.

Not only is appellant supported by the clearly manifested Congressional intent outlined herein, but it is entitled to rely upon the express statements published by the Commissioner of Internal Revenue in his regulations and rulings. Appellant urges that the decision of the Tax Court must be reversed.

**C. The oral contract between appellant and Coast was not a disposal of timber on the date thereof under the then existing laws and regulations.**

The deficiencies are based upon the theory that the profits realized by appellant in the years 1948 and 1949 from the Sage timber removed by Coast were ordinary income, the timber having been disposed of by the oral or implied agreement of 1947. The basic question presented is whether the oral or implied contract between appellant and Coast in October, 1947 (R 18), constituted a "disposal" of the timber covered by the Sage Agreement, under the provisions of Sec. 117 (k) (2) of the Internal Revenue Code of 1939. That statute provides as follows:

"(2) In the case of the disposal of timber (held for more than six months prior to such disposal) by the owner thereof under any form or type of contract by virtue of which the owner retains an economic interest in such timber, the difference between the amount received for such timber and the adjusted depletion basis thereof shall be considered as though it were a gain or loss, as the case may be, upon the sale of such timber."

In *Springfield Plywood Corporation v. Commissioner*, 15 TC 697 (1950), the taxpayer purchased timber in January, 1943, and entered into a written cutting contract in May, 1943, which was held to constitute a



“disposal” of the timber on that date. The decision turned on the court’s finding that:

*“In our view, the timber involved was all sold on May 14, 1943, and only payment, as agreed, was delayed. However, as above seen, even without sale, in our opinion within the statute and within a reasonable and valid regulation, disposal took place on that date.”* (Emphasis supplied)

In the present case, there is no evidence that the timber was “disposed of” prior to the execution by appellant and Coast of their written agreement in 1950 (Exhibit 2-B; R 72). The oral agreement here may be distinguished from the written agreement in the *Springfield Plywood Corporation* case in the following particulars:

(a) The agreement did not obligate Coast to pay for timber which it did not remove.

(b) Appellant bore the fire risk through 1948 and 1949.

(c) Appellant sold 33,883,000 board feet to A. K. Wilson Lumber Co. in 1950 (R 19).

Here, the oral or implied agreement contemplated only *an oral license to cut timber as desired, with Coast required to pay only for logs removed, as removed, at a fixed price* (R 18).

In *Sorensen v. Jacobson*, 125 Mont. 148, 232 P. 2d 332, at page 335, 26 ALR 2d 1186 (1951), the Court, in speaking of a parol license to enter, cut and remove timber, said:

“By the weight of authority such a parol or simple contract for the sale of growing timber, to be cut and removed from the land by the purchaser, is not to be construed as intended by the parties to convey any interest in land, but as an executory contract for the sale of the timber after it shall have been severed from the soil. Such a contract implies a license to enter the lands of the licensor for the purpose of severing the timber and removing the same. The severing of the trees constituted part performance of the contract, the logs becoming the personal property of the licensee. Such partly performed contract does not come within the provisions of the Statute of Frauds. (RCM 1947, § 13-606; *Stillinger v. Kelly*, 66 Mont. 441, 443, 214 P. 66; Restatement, Contracts, § 200 (c).

\* \* \* \* \*

“It is also well settled that, while the license to enter upon the land and cut timber thereon is irrevocable as to that part of the timber which has been severed from the land, yet while the contract remains executory it is revocable at the will of the owner of the land.”

In *Gullicksen v. Shadoan*, 124 Mont. 56, 218 P. 2d 714 (1950), at page 719, the Court said:

“We have read all the cases cited herein and while the questions are not free from difficulty and

there being eminent authority to the contrary, we believe the weight of authority and the better reasoning is expressed and set forth in *Emerson v. Shores*, 95 Me. 237, 49 A. 1051, 1052, 85 Am. St. Rep. 404, being a very similar case, where the court said:

“It has accordingly become settled law under the decisions of this court, and by the great weight of authority elsewhere, that parol or simple contracts for the sale of growing wood or timber, to be cut and removed from the land by the purchaser, are not to be construed as intended by the parties to convey any interest in land, but as executory contracts for the sale of the timber after it shall have been severed from the soil and converted into chattel property, together with a license to enter upon the land for the purpose of cutting and removing it.

\* \* \* \* \*

“*It is equally well settled that, while the license to enter and cut timber, thus created by parol or simple contracts, is irrevocable as to that part of the timber which has been severed from the land in execution of the contract; yet, while it remains executory as to the wood or timber not yet severed from the land, it is revocable not only at the will of the owner, but by his death, or by his conveyance of the land without reservation.*”

“*Buker v. Bowden*, 83 Me. 67, 69, 21 A. 748; *Banton v. Shorey*, 77 Me. 48; *Russell v. Richards*, 10 Me. 429, 25 Am. Dec. 254; *Folsom v. Moore*, 19 Me. 252; *Brown v. Dodge*, 32 Me. 167; *Drake v. Wells*, 11 Allen 141 (93 Mass. 141). *Giles v. Simonds*, 15 Gray 441, 77 Am. Dec. 373; *Douglas v. Shumway*, 13 Gray 498; *White v. Foster*, 102 Mass. 375; *Fletcher v. Livingston*, 153 Mass. 388, 26 N.E. 1001; *Cook v. Stearns*, 11 Mass. 533; 13 Am. & Eng. Enc. Law (1st Ed.), p. 555.” (Emphasis supplied)

The question then is whether an oral license to enter and cut timber constitutes a "disposal" within the terms of 1939 IRC § 117 (k) (2).

A license in real property may be defined as a personal, unassignable and ordinarily revocable privilege which may be created by parol to do one or more acts on the land without possessing any interest therein. A license is an authority to do a lawful act which without it would be unlawful, and while it remains unrevoked, a license justifies the acts which it authorizes to be done. This is true even of a bare parol license given without consideration. 33 Am. Jur. 398 (Licenses § 91).

A case similar on its facts is *Anderson v. Moothart*, 198 Or. 354, at page 357, 256 P. 2d 257 (1953). In that case the Court said:

"The agreement between the parties in this suit was oral, but, whether written or oral, the result would be the same, for the defendants were not purchasing the timber as it stood but only as it was severed from the real property and became personalty, to be paid for at the rate of \$2.00, and then later \$3.50 per one thousand board feet *as scaled*. *Coquille Mill & Tug Co. v. Robert Dollar Company*, 132 Or. 453, 469, 285 P. 244. Such an agreement creates only a license to enter upon the lands of the licensor for the purpose of cutting and removing the timber. *Coquille Mill & Tug Co. v. Robert Dollar Company*, *supra*; *Elliott v. Boyd*, 40 Or. 326, 67 P. 202; *Sorensen v. Jacobsen*, (Mont.) 232 P. 2d 332.

And while the agreement remains executory it is revocable at any time at the will of the licensor, unless such valuable and permanent improvements had been made in reliance thereon that it would amount to the perpetration of a fraud if the license were revoked. 1 Thompson on Real Property, Perm. Ed., § 115, p. 163; *Beckman v. Brickley*, 144 Wash. 558, 258 P. 488; *David v. Brokaw*, 121 Or. 591, 256 P. 186.” (Emphasis supplied)

The rule with regard to parol licenses is the same in California. *Broads v. Mead*, 159 Cal. 765, 116 Pac. 46 (1911).

In the case of *Bomberger v. McKelvey*, 35 Cal. 2d 607, 220 P. 2d 729, at page 736, the California Supreme Court said:

“A mere license to enter or use premises may be revoked at any time by the licensor. See *County of Alameda v. Ross*, 32 Cal. App. 2d 135, 143, 89 P. 2d 460; 16 Cal. Jur. 285; 33 Am. Jur. 404.”

The authorities are uniform in stating that an oral license to enter, cut and remove timber, is revocable by the grantor at any time as to timber remaining uncut. Therefore, there *cannot* be a “disposal” of the timber at the time the license is granted, insofar as 1939 IRC § 117 (k) (2) is concerned.

Appellant having granted a parol license, there is no “disposal” until such time as the licensee has actu-

ally cut and removed the timber from the property. Appellant is entitled to long-term capital gains treatment of the profits arising from timber removed by Coast from the Sage tract at any time subsequent to April, 1948. The decision of the Tax Court must be reversed and remanded, with directions to accept appellant's returns as correctly reporting the income received from Coast during 1948 and 1949 as long term capital gains.

## II.

THE TAX COURT ERRED IN ITS DETERMINATION THAT APPELLANT'S DEPLETION ALLOWANCE FOR THE TAXABLE YEARS 1948 AND 1949 IS NOT ADJUSTABLE TO CORRECTLY REFLECT THE UNITS OF TIMBER STANDING ON APPELLANT'S PROPERTY DURING THOSE YEARS.

**A. The depletion allowance for 1948 and 1949 is adjustable because of gross error, misrepresentation or fraud.**

The statute in effect during the years in question was Sec. 23 (m) of the Internal Revenue Code of 1939. That section provides as follows:

“In the case of mines, oil and gas wells, other natural deposits, and timber, a reasonable allowance for depletion and for depreciation of improvements, according to the peculiar conditions in each

case; such reasonable allowance in all cases to be made under rules and regulations to be prescribed by the Commissioner, with the approval of the Secretary. In any case in which it is ascertained as a result of operations or of development work that the recoverable units are greater or less than the prior estimate thereof, then such prior estimate (but not the basis for depletion) shall be revised and the allowance under this subsection for subsequent taxable years shall be based upon such revised estimate.”

The applicable regulation was Reg. 111, § 29.23 (m) -22. It provided:

*“Revaluation of timber not allowed.* No revaluation of a timber property whose value as of any specific date has been determined and approved will be made or allowed during the continuance of the ownership under which the value was so determined and approved, *except in the case of misrepresentation or fraud or gross error as to any facts known on the date as of which the valuation was made.* Revaluation on account of misrepresentation or fraud or such gross error will be made only with the written approval of the Commissioner. The depletion unit should be changed when a revision of the remaining number of units of recoverable timber in the property has been made in accordance with section 29.23 (m) -26.”

The statute and regulation are clear; a revision of the basis for depletion will be allowed only when mis-

representation or fraud or gross error exists with regard to facts known on the date the valuation was made.

The record discloses that when the depletion unit of \$3.941566 per thousand board feet was computed, both appellant and respondent believed that the amount of timber on the Sage Tract was that shown on Schedule A of Exhibit 1-A (R 18-19). The depletion allowance was computed on this figure.

According to Witness Adkins (R 41), the actual amount of timber remaining on the Sage lands in the fall of 1954 was 37 million board feet. If the amount of timber shown by Schedule A of Exhibit 1-A had been correct, there should have been remaining 220 million board feet. Since the total amount of timber on the lands according to Exhibit 1-A was originally 382 million board feet, there was therefore an underrun of approximately 48 per cent.

The Tax Court failed to distinguish between adjustment of the depletion deduction in years subsequent to the year of discovery of an error in the amount of timber present on the tract and revaluation of the depletion basis as of the date of the acquisition of the timber with resulting adjustments of depletion deductions in all open years subsequent to the date of acquisition. Appellant seeks the latter, basing its claim upon misrepresen-



tation, fraud or gross error as provided by statute and established by the record. A falldown of 48 per cent must and clearly does constitute misrepresentation or fraud or gross error, or possibly all three, within the meaning of the statute.

In *Rust-Owen Lumber Co. v. Commissioner*, 74 Fed. 2d 18 (7th Cir., 1934), the court considered the problem of depletion basis to be permitted to a taxpayer with regard to cutting of timber. In determining that the taxpayer should be permitted to revalue its timber as of the original date of valuation, and should be allowed to claim increased depletion allowances, the court said (at page 21):

“The Commissioner contends that when subsequent operations disclosed an increase in quantity of timber it was his duty to correct the quantity of reserve to reflect the increase, in order to correctly determine the percentage of annual depletion so that the recovery of the entire capital might coincide with the conclusion of the cutting. This is quite true, but he further insists that it was also his duty, at the same time, to revise the unit value, or the value per thousand feet of the timber. In this we think the Commissioner is in error. *His conclusion in this respect could be true only in case the amount of capital investment were based on cost, rather than actual value.* We hold that petitioner’s capital investment must be the entire actual footage of the pine at the rate of \$14 per thousand feet, plus the entire actual footage of the other timber at the rate of \$4 per thousand feet. It is true that article 230 of the Treasury Regulations provides that the unit

market value of timber will subsequently be changed if from any cause such unit market value if continued as a basis of depletion shall, upon evidence satisfactory to the Commissioner, be found inadequate or excessive for the extinguishment of the fair market value as of March 1, 1913. With that regulation, reasonably used for the purposes of carrying out the provisions of the statute, we have no complaint, *but it can not be used to limit the rights plainly granted by the statute* (*Morrill v. Jones*, 106 U.S. 466, 1 S. Ct. 423, 27 L. Ed. 267), even though the statute be re-enacted after the promulgation of the regulation.

\* \* \* \* \*

“It is contended by the Commissioner, however, that even though the estimate of the quantity of timber on March 1, 1913 was less than the actual amount, the remaining reserve can not be corrected and the unexhausted value apportioned to the corrected quantity, thus obtaining revised depletion rates, because under the treasury regulations, the timber reserve may not be revalued during the same ownership except for fraud, misrepresentation, or gross error. In this case the ownership remained the same and it is admitted that there was neither fraud nor misrepresentation; but that there was gross error in estimating the timber reserve as of 1913, is alleged by petitioner and denied by the Commissioner.

“The final cut of the timber disclosed that there was gross error in prior estimates of the timber reserve. The overrun amounted to more than 45,000,000 feet, which at its actual value would increase the capital investment by more than \$300,000, and if reflected in the depletion account would increase petitioner’s total depletion deductions for

1927, 1928 and 1929, over those allowed by the Commissioner, by almost \$260,000. The tax involved is more than \$36,000. These figures seem to us to be more than trivial in their import and convince us that there was gross error in the prior estimates within the meaning of the Statute and the treasury regulations.”

Certainly the term “gross error” should apply to a transaction wherein the appellant acquired only half of what it bargained for. That there existed a misrepresentation of material fact cannot be questioned. It is equally apparent that the so-called “underrun” did exist during the years in question.

Appellant’s returns for the years 1948 and 1949 are open for review by virtue of this proceeding, and the Tax Court has the power and the duty to determine the deficiency, if any, of appellant. The adjustment to appellant’s depletion basis and depletion allowance for the years 1948 and 1949 should be allowed. The decision must be reversed and remanded with directions to recompute the depletion basis and therefore the depletion allowances of appellant for the years in question.

## CONCLUSION

Appellant, throughout the years in question, used the Sage timber in a manner normal and customary for timber and logging companies. Having acquired the timber, it licensed Coast to remove it, at such time and in such amounts as the licensee might desire. The price to be paid for the timber, when and if removed, was fixed and certain. Appellant's returns reflected this method of operation. It reported as long-term capital gains the profits realized on the timber removed during the years in question.

The evidence in the case is undisputed and clear. The timber was sold from time to time as cut. All timber held by appellant for more than six months prior to sale is entitled to long-term capital gains treatment under the provisions of 1939 IRC Sec. 117 (k) (2).

The authorities presented clearly support appellant's contention and further establish that appellant is entitled to recomputation and adjustment of its depletion basis and depletion allowance. The refusal of the Tax Court to allow such recomputation is arbitrary and without basis in law.

To permit the decision of the Tax Court to stand will jeopardize the business methods developed by timber

owners since the first enactment of 26 USCA Sec. 631 (1939 IRC Sec. 117 (k) ). Timber owners will be forced to sacrifice established methods of operation in order to reduce their vulnerability to similar rulings made upon issues not raised before the Tax Court.

The record of this case, and the authorities cited herein, make imperative an express ruling that an owner of timber otherwise complying with IRC Sec. 631 is entitled to capital gains treatment on timber sold *regardless* of the nature of his business or the purpose for which the timber is held.

The Commissioner of Internal Revenue by his ruling of March 11, 1957 (Rev. Rul. 57-90, 1957-10 I.R.B. 17) specifically granted relief to all other timber owners. Appellant's relief under the ruling must come from this court.

Appellant is entitled to a decision directing the acceptance of appellant's returns for 1948 and 1949 as filed insofar as they report amounts received from Coast as long-term capital gains. Furthermore, the Court must direct that the depletion basis of the Sage timber be revalued as of the date of its acquisition by appellant, and, based upon such revaluation, must further direct

the adjustment of appellant's depletion allowance for the years 1948 and 1949.

Appellant is clearly entitled to the relief it seeks. The judgment of the Tax Court of the United States must be reversed.

Respectfully submitted,  
KOERNER, YOUNG, McCOLLOCH  
& DEZENDORF  
JAMES C. DEZENDORF  
MARSHALL C. CHENEY, JR.  
*Attorneys for Petitioner.*

## APPENDIX

1. 26 USCA § 7453.—Rules of practice, procedure, and evidence.

“The proceedings of the Tax Court and its divisions shall be conducted in accordance with such rules of practice and procedure (other than rules of evidence) as the Tax Court may prescribe and in accordance with the rules of evidence applicable in trials without a jury in the United States District Court of the District of Columbia. Aug. 16, 1954, 9:45 a.m., E.D.T., c. 736, 68A Stat. 884.”

2. Tax Court Rule 31. Evidence and the submission of evidence. (a) Rules applicable.—“The proceedings of the Court and its Divisions will be conducted in accordance with the rules of evidence applicable in trials without a jury in the United States District Court for the District of Columbia.”

3. Rule 52 (a)—Federal Rules of Civil Procedure:

“*Effect.* In all actions tried upon the facts without a jury or with an advisory jury, the court shall find the facts specially and state separately its conclusions of law thereon and direct the entry of the appropriate judgment; and in granting or refusing interlocutory injunctions the court shall similarly set forth the findings of fact and conclusions of law which constitute the grounds of its action. Requests for findings are not necessary for purposes of review. Findings of fact shall not be set aside unless clearly erroneous, and due regard shall be given to the opportunity of the trial court to judge the credibility of the witnesses. The findings of a master, to the extent that the court adopts them, shall be considered as the findings of the court. If an opinion or memorandum of decision is filed, it will be sufficient if the findings of fact and conclusions of law appear therein. Findings of fact and conclusions of law are unnecessary on decisions of motions under Rules 12 or

56 or any other motion except as provided in Rule 41 (b). As amended Dec. 27, 1946, effective March 19, 1948.”

4. 1944 C.B. 993, 1015 read as follows:

“If the taxpayer so elects upon his return, the cutting of timber during the year by the taxpayer who owns or has a contract right to cut such timber is treated as a sale or exchange of the timber cut during the year and such cut timber is considered property used in a trade or business of the taxpayer for the purpose of section 117 (j) of the Internal Revenue Code provided the taxpayer has owned such timber or held such contract right for a period of more than six months prior to the beginning of such year. Where such an election is made, gain or loss to the taxpayer is recognized in an amount equal to the difference between the adjusted basis for depletion of such timber in the hands of the taxpayer and the fair market value of such timber. The fair market value is determined as of the first day of the taxable year in which the timber is cut.

“The election which is made is binding on the taxpayer with respect to all timber which he owns or which he has a contract right to cut and is also made binding for all subsequent years unless the Commissioner, upon the showing of undue hardship, permits the taxpayer to revoke his election.

“If an owner of timber disposes of it under a contract by virtue of which he retains an economic interest in such timber, the amount received by such owner is to be treated in a similar manner.”

\* \* \* \* \*

“Under section 117 (k) (2) as added by this section, in the case of timber which has been disposed of by the owner, who has held it for more than six months prior to such disposal, under any form or type of contract by virtue of which the owner retains an economic



interest in such timber, the difference between the amount received for such timber and the adjusted basis for depletion of such timber in the hands of the owner, shall be considered as though it were a gain or loss, as the case may be, upon the sale of such timber. *Such timber shall be considered 'property used in the trade or business' of the owner within the meaning, and for the purposes, of Section 117 (j).*

“Subsection (b) of this section amends section 117 (j) (1) of the Code by including within the definition of ‘property used in the trade or business,’ timber as provided in section 117 (k). Thus gain or loss arising from the cutting of timber with respect to which an election has been made under section 117 (k) (1), and from timber which has been disposed of, as provided in section 117 (k) (2), shall be considered, or shall not be considered, as gains or losses from the sales or exchanges of capital assets under the provisions of section 117 (j), depending upon the operation of such section in the case of the taxpayer.” (Emphasis supplied)

5. 1944 C.B. 1059, 1068 reads as follows:

“Under section 117 (k) (2), as added by this amendment, if a taxpayer who has owned timber for more than six months disposes of such timber under any form or type of contract by virtue of which the owner retains an economic interest in such timber, the difference between the amount received for such timber and the adjusted basis for depletion of such timber in the hands of the owner shall be considered as though it were a gain or loss, as the case may be, upon the sale of such timber. *Such timber shall be considered 'property used in the trade or business' of the owner for the purposes of section 117 (j).*

“Section 117 (j) (1) of the Code is amended by including within the definition of ‘property used in the trade or business,’ timber as provided in section 117 (k).” (Emphasis supplied)



No. 15434

---

---

In the United States Court of Appeals  
for the Ninth Circuit

---

AH PAH REDWOOD CO., A CORPORATION, PETITIONER

v.

COMMISSIONER OF INTERNAL REVENUE, RESPONDENT

---

On Petition for Review of the Decision of the  
Tax Court of the United States

---

BRIEF FOR THE RESPONDENT

---

CHARLES K. RICE  
*Assistant Attorney General*

ROBERT N. ANDERSON  
WALTER R. GELLES  
*Attorneys*  
*Department of Justice*  
*Washington 25, D.C.*

---

---

FILED

JUL - 1 1957



## INDEX

	Page
Opinion below .....	1
Jurisdiction .....	1
Questions presented .....	3
Statute and Regulations involved.....	3
Statement .....	3
Summary of argument.....	5
Argument:	
I. Taxpayer did not hold the timber for a period more than six months prior to disposal and is thus not entitled to capital gains treatment	8
II. The revised estimate of board feet of timber, made in 1954, cannot be applied retroactively to adjust taxpayer's depletion allowance for 1948 and 1949.....	16
Conclusion .....	25
Appendix .....	26

## CITATIONS

### Cases:

<i>Ah Pah Redwood Co. v. Commissioner</i> , 26 T.C. 1197 .....	1, 9
<i>Anderson v. Helvering</i> , 310 U.S. 404.....	17
<i>Bates v. Babcock</i> , 95 Cal. 479, 30 Pac. 605.....	11
<i>Beck v. Commissioner</i> , 15 T.C. 642, affirmed, 194 F. 2d 537.....	19, 20
<i>Boeing v. United States</i> , 98 F. Supp. 581.....	8
<i>Brewster v. Gage</i> , 280 U.S. 327.....	13
<i>Burnet v. Harmel</i> , 287 U.S. 103.....	10
<i>Camp v. Commissioner</i> , 21 B.T.A. 962.....	11
<i>Charlotte Union Bus Station v. Commissioner</i> , 209 F. 2d 586.....	11
<i>Commissioner v. Boeing</i> , 106 F. 2d 305, certiorari denied, 308 U.S. 619.....	9
<i>Commissioner v. Wheeler</i> , 324 U.S. 542, rehearing denied, 325 U.S. 892.....	13
<i>Finch, Joseph S., &amp; Co. v. Commissioner</i> , 23 B.T.A. 1153 .....	11
<i>Helvering v. Elbe Oil Land Co.</i> , 303 U.S. 372.....	17
<i>Helvering v. Reynolds Co.</i> , 306 U.S. 110.....	16
<i>Helvering v. Winmill</i> , 305 U.S. 79.....	16

II

Cases—Continued

Page

<i>Jordan v. Federal Farm Mortgage Corp.</i> , 152 F. 2d 642 .....	2
<i>Kehota Mining Co. v. Lewellyn</i> , 28 F. 2d 994, affirmed, 30 F. 2d 817.....	20
<i>Keyser v. Farr</i> , 105 U.S. 265.....	2
<i>Maletis v. United States</i> , 200 F. 2d 97.....	21
<i>Marbelite Corp. v. Commissioner</i> , 77 F. 2d 713....	11
<i>McCahill v. Helvering</i> , 75 F. 2d 725.....	20, 22
<i>Miller v. United States</i> , 114 F. 2d 267.....	2
<i>O'Brien v. O'Brien</i> , 197 Cal. 577, 241 Pac. 861.....	11
<i>Petit Anse Co. v. Commissioner</i> , 155 F. 2d 797....	19, 22
<i>Robison v. Hanley</i> , 136 C.A. 2d 820, 289 P. 2d 560 .....	11
<i>Rust-Owen Lumber Co. v. Commissioner</i> , 74 F. 2d 18 .....	24
<i>Secretary of Banking of Pennsylvania v. Alker</i> , 183 F. 2d 429.....	2
<i>Springfield Plywood Corp. v. Commissioner</i> , 15 T.C. 697 .....	6, 13
<i>Switzer v. Marzall</i> , 94 F. Supp. 721.....	2
<i>Theatres, J. J., Inc. v. Twentieth Century-Fox Film Corp.</i> , 112 F. Supp. 674.....	2
<i>Thompson v. Harry C. Erb., Inc.</i> , 240 F. 2d 452....	2
<i>United States v. Armature Exchange</i> , 116 F. 2d 969, certiorari denied, 313 U.S. 573.....	16
<i>Universal Battery Co. v. United States</i> , 281 U.S. 580 .....	13
<i>Walleck v. Hudspeth</i> , 128 F. 2d 343.....	2
<i>Watson v. Commissioner</i> , 345 U.S. 544, rehearing denied, 345 U.S. 1003.....	10
<i>Willey v. Commissioner</i> , decided December 7, 1950, affirmed, 199 F. 2d 375.....	9

Statute:

Internal Revenue Code of 1939:

Sec. 22 (26 U.S.C. 1952 ed., Sec. 22).....	26
Sec. 23 (26 U.S.C. 1952 ed., Sec. 23).....	26
Sec. 113 (26 U.S.C. 1952 ed., Sec. 113).....	27
Sec. 114 (26 U.S.C. 1952 ed., Sec. 114).....	28
Sec. 117 (26 U.S.C. 1952 ed., Sec. 117).....	28

III

Page

Miscellaneous:

97 Cong. Record, Part 10:

P. 13435 .....	15
P. 13628 .....	16
Rev. Rul. 57-90, 1957-10 Int. Rev. Bull. 9.....	9
S. Rep. No. 665, 72d Cong., 1st Sess., p. 16 (1939-1 Cum. Bull. (Part 2) 496, 507-508).....	18
S. Rep. No. 781, Part 2, 82d Cong., 1st Sess., p. 44 (1951-2 Cum. Bull. 545, 575).....	15
Treasury Regulations 111:	
Sec. 29.23(m)-1 .....	30
Sec. 29.23(m)-22 .....	31
Sec. 29.23(m)-26 .....	31
Sec. 29.117-8 .....	32





**In the United States Court of Appeals  
for the Ninth Circuit**

---

No. 15434

AH PAH REDWOOD CO., A CORPORATION, PETITIONER

*v.*

COMMISSIONER OF INTERNAL REVENUE, RESPONDENT

---

**On Petition for Review of the Decision of the  
Tax Court of the United States**

---

**BRIEF FOR THE RESPONDENT**

---

**OPINION BELOW**

The findings of fact and opinion of the Tax Court (R. 16-28) are reported at 26 T.C. 1197.

**JURISDICTION**

This petition for review (R. 29-32) involves federal income taxes for the taxable years 1948 and 1949. On June 18, 1953, the Commissioner of Internal Revenue mailed the taxpayer a notice of deficiency which, together with penalties (Section 291 (a) of the Internal Revenue Code of 1939), totalled

\$47,880.27 (R. 5-7). Within ninety days thereafter, and on September 16, 1953, the taxpayer filed a petition with the Tax Court for a redetermination of the deficiency under the provisions of Section 272(a) of the 1939 Code. (R. 3-5.) The decision of the Tax Court, in favor of the Commissioner, was entered October 28, 1956. (R. 28.) On October 29, 1956, taxpayer filed with the Tax Court a motion for revision of the decision of October 28, 1956.<sup>1</sup> (R. 76-82.) The case is brought to this Court by a petition for review filed December 18, 1956. (R. 29-31.) Jurisdiction is conferred on this Court by Section 7482 of the Internal Revenue Code of 1954.

---

<sup>1</sup> Taxpayer filed a petition for review by this Court without action having been taken by the Tax Court on the motion for revision. It appears that the Tax Court took no action on the motion for revision after the petition for review was perfected. The filing of a notice of appeal or petition for review from a final judgment or decision terminates all further jurisdiction of the lower court and transfers jurisdiction to the appellate tribunal. *Keyser v. Farr*, 105 U.S. 265; *Thompson v. Harry C. Erb., Inc.*, 240 F. 2d 452 (C.A. 3d); *Jordan v. Federal Farm Mortgage Corp.*, 152 F. 2d 642 (C.A. 8th); *Walleck v. Hudspeth*, 128 F. 2d 343 (C.A. 10th); *Miller v. United States*, 114 F. 2d 267 (C.A. 7th). There is authority that this holds true even where the motion with the lower court was filed and pending at the time the notice of appeal was filed. *Secretary of Banking of Pennsylvania v. Alker*, 183 F. 2d 429 (C.A. 3d); *Switzer v. Marzall*, 94 F. Supp. 721 (D.C. D.C.); *J. J. Theatres, Inc. v. Twentieth Century-Fox Film Corp.*, 112 F. Supp. 674 (S.D. N.Y.). The theory would be that where a moving party invokes the jurisdiction of an appellate court by filing a notice of appeal, he will be deemed to have abandoned, and in effect withdrawn, any motions he has pending in the lower court.

## QUESTIONS PRESENTED

1. Whether amounts received by taxpayer during 1948 and 1949 from Coast Redwood Company resulted from a disposal of timber held for less than six months prior to such disposal under Section 117 (k) (2) of the Internal Revenue Code of 1939, as held by the Tax Court, or whether, as taxpayer contends, the timber had been held for more than six months prior to disposal.

2. Whether the Tax Court erred in holding that taxpayer's depletion allowance could not be adjusted retroactively for 1948 and 1949 under Section 23 (m) of the 1939 Code so as to reflect a revision, made in 1954, of the original estimate of board feet of timber.

## STATUTE AND REGULATIONS INVOLVED

The pertinent provisions of the statute and Regulations involved are set forth in the Appendix, *infra*.

## STATEMENT

The facts of this case are undisputed and are taken from the Tax Court's findings (R. 16-19), the transcript of testimony (R. 37-57), and exhibits introduced into evidence (R. 57-76).

The taxpayer, Ah Pah Redwood Co., is a corporation organized under the laws of California, with its main office at Portland, Oregon. It filed its returns for the tax years 1948 and 1949 on a calendar year basis. (R. 16-17.)

By contract dated December 13, 1946 (hereinafter called the Sage Agreement), Union Bond & Trust Company agreed to purchase from the Sage Land &

Lumber Company, Inc., all the land and timber on certain tracts described therein (hereinafter called the Sage Tract) in Humboldt County, California. (R. 17-18; Ex. 1-A, R. 57-71.) Mr. A. K. Wilson was the president of Union Bond & Trust Company, as well as president of International Pacific Pulp and Paper Company (R. 51-52) which acquired rights in the Sage Agreement and which sold 16,022,060 board feet of the timber covered therein to Coast Redwood Company, Inc. (hereinafter referred to as Coast Redwood), during 1946 and 1947 (R. 19, 47).

Upon its organization in October, 1947, taxpayer purchased all the right, title, and interest of "the buyer" in the Sage Agreement and all of the timber and land covered thereby for \$1,443,838.99. (R. 17-18. ) Shortly after this purchase, taxpayer, in October, 1947, under an oral or implied contract with Coast Redwood, allowed the latter to begin cutting timber from the Sage Tract and pay therefor \$5.00 per thousand feet as removed. On January 9, 1950, taxpayer entered into a formal written agreement with Coast Redwood pursuant to which the former agreed to sell to the latter all of the timber and land covered by the Sage Agreement. (R. 18.)

During 1950, taxpayer sold 33,883,000 board feet of timber covered by the Sage Agreement to the A. K. Wilson Lumber Company. (R. 19.) Mr. A. K. Wilson was also president of the taxpayer corporation as well as president of Coast Redwood and A. K. Wilson Lumber Company. (R. 51-52.)

In the years 1948 and 1949, taxpayer reported its income from the receipts from Coast Redwood as

long term capital gains. It used a basis for depletion of \$3.941566 per thousand board feet. This basis, which was agreed to by the Commissioner, was arrived at by dividing the amount of timber on the Sage Tract, as was shown on Schedule A of the Sage Agreement per the French cruise, which amount taxpayer assumed to be the correct quantity thereof, into the total purchase price paid by taxpayer for such agreement. In 1952, taxpayer first became aware of the fact that Schedule A of the Sage Agreement erroneously overstated the quantity of timber on the Sage Tract by a substantial amount. The Tax Court found that, upon an actual cruise made shortly after logging operations ceased in November of 1954, it was ascertained that such overstatement was approximately double the actual amount and that there was a "fall-down" of approximately 48 per cent. (R. 18-19.) According to the French cruise approximately 70 million board feet should have remained on the Sage Tract as of November, 1954, whereas the new cruise showed that approximately 35 to 37 million board feet remained standing on the tract. (R. 41, 43-44.)

The Tax Court held that taxpayer was not entitled to capital gains treatment for 1948 and 1949, and that the 1954 revision of the depletion rate could not be applied retroactively to those years. (R. 19-27.)

## SUMMARY OF ARGUMENT

### I

The Tax Court was correct in holding that taxpayer's oral agreement with Coast Redwood constituted a disposal of the Sage timber, and that inas-

much as taxpayer had not held the timber for a period of more than six months at the time of such disposal, capital gains treatment was not available under Section 117(k)(2).

Taxpayer's contention that, if the agreement created only a license to cut and remove timber, there was no disposal of any particular timber until it was cut and removed, is obviously incorrect. The statute states that disposal of the timber must be "under" a "contract", thus clearly contemplating that the date of disposal is the date of the contract. All of the timber cut and removed during 1948 and 1949 was disposed of by the oral contract.

Taxpayer's theory is in direct conflict with Treasury Regulations 111, Section 29.117-8, which state that, to qualify for capital gains treatment, a taxpayer must have owned the timber "for a period of more than six months *prior to the date* of such contract." (Italics supplied.) The Tax Court, in *Springfield Plywood Corp. v. Commissioner*, 15 T.C. 697, 703, approved this regulation as "reasonable and valid", and proceeded to hold that a "cutting license" disposed of the timber on the date the parties entered into the agreement, and since the taxpayer had not held the timber for more than six months prior to such agreement, capital gains treatment was unavailable. Congress was made expressly aware of the *Springfield Plywood* decision and of the Bureau's interpretation of the statute, but a bill which would have changed the law so that the date of disposal would be deemed to be the date the timber was cut, was rejected by both houses. Since ulti-

mately no revision of Section 117(k) (2) was made, Congress must be considered as having approved the Bureau's interpretation.

Inasmuch as the oral contract was entered into the same month that taxpayer acquired the timber, taxpayer had not held the timber for a period of more than six months prior to disposal and cannot, therefore, qualify for capital gains treatment.

## II

Assuming that the Tax Court was correct in denying capital gains treatment, taxpayer is entitled to deductions for depletion. But taxpayer, having discovered in 1954 that the original estimate of standing timber was overstated, may not apply the revised estimate retroactively to adjust upward the depletion deductions for 1948 and 1949. Section 23(m) of the 1939 Code very clearly directs that a revision of the unit rate of depletion, based upon a new estimate of the recoverable units, shall only be applied "for subsequent taxable years". Three other Circuits have construed this language as meaning that the revised estimate may only be applied prospectively. Similarly, Section 29.23(m)-26 of Regulations 111, conforms exactly to the language of the statute, forbidding a retroactive adjustment.

Section 29.23(m)-22 of Regulations 111, which taxpayer claims authorizes a retroactive application, has no reference to the problem at hand. That section relates to the matter of *revaluation* of the basis of the timber property, as opposed to a redetermination of the quantity of timber with which Section

23(m) and Section 29.23(m)-26 of Regulations 111 are concerned. Similarly the case on which taxpayer relies is not pertinent, as the court was dealing with revaluation and not revision of units.

It may be that there was gross error in the original estimate. But such a conclusion does not dispose of this case. For that matter, taxpayer need not prove gross error at all to have a revision under the appropriate section of the Regulations. But once having established that a revision is in order, Section 23(m) of the Code makes very clear that the revision must be applied so as to recapture the remaining costs in "subsequent taxable years".

## ARGUMENT

### I

#### Taxpayer Did Not Hold the Timber For a Period of More Than Six Months Prior To Disposal and Is Thus Not Entitled To Capital Gains Treatment

The Tax Court decided the capital gains issue for the Commissioner on two grounds. The Tax Court held first that capital gains treatment is not available under Section 117(j) and (k)(2) of the 1939 Code (Appendix, *infra*) where the timber disposed of was held for sale to customers in the ordinary course of business. See *Boeing v. United States*, 98 F. Supp. 581 (C. Cls.).<sup>2</sup> The Tax Court also held

---

<sup>2</sup> In the *Boeing* case, the Court of Claims concluded, after tracing the legislative history of Section 117(k)(2), that the taxpayer was entitled to capital gains treatment on the Greenwood contract (pp. 584-585)—

unless perhaps it can be said that plaintiff was in the



that taxpayer's oral agreement with Coast Redwood constituted a disposal of the Sage timber, and inasmuch as taxpayer had not held the timber for a period of more than six months at the time of such disposal, capital gains treatment was not available under Section 117(k) (2).

The Commissioner did not urge the "for sale to customers in the ordinary course of business" argument, adopted by the Tax Court, and has since stated that this ground for the decision does not represent the position of the Internal Revenue Service.<sup>3</sup> Accordingly, on the capital gains issue we direct at-

---

trade or business of selling timber to logging companies.

The court held that the taxpayer was not in the business of selling timber, but was merely liquidating an investment, and, therefore, having otherwise qualified under Section 117(k) (2), was entitled to capital gains. See also *Willey v. Commissioner*, decided December 7, 1950 (1950 P-H T.C. Memorandum Decisions, par. 50,299), affirmed, 199 F. 2d 375 (C.A. 6th); *Commissioner v. Boeing*, 106 F. 2d 305 (C.A. 9th), certiorari denied, 308 U.S. 619.

<sup>3</sup> Rev. Rul. 57-90, 1957-10 Int. Rev. Bull. 9, states as follows:

In the case of the disposal of timber, held for more than six months prior to such disposal, by the owner thereof under any form or type of contract by virtue of which the owner retains an economic interest in such timber, pursuant to the provisions of Section 631(b) of the Internal Revenue Code of 1954, the gain or loss on such disposal is subject to the tax treatment provided by Section 1231 regardless of the nature of the taxpayer's business or the purpose for which the timber is held. To the extent that the opinion in *Ah Pah Redwood Co. v. Commissioner*, 26 T.C. 1197, may be inconsistent with the foregoing, it does not represent the position of the Internal Revenue Service.

tention only to the question whether the taxpayer held the timber for a period of more than six months before disposal.

Taxpayer argues that the oral agreement was only a license to cut timber (Br. 25), and that since such a license is revocable, there could be no disposal until the timber was cut and removed (Br. 29-30). We do not concede that the agreement was a cutting license. The burden was on taxpayer to prove that it qualified under Section 117(k), and having offered insufficient evidence of the legal rights and duties created by the agreement,<sup>4</sup> taxpayer assumes too much in positively characterizing it a cutting license. Having failed to establish that the agreement was a license, the whole substance of taxpayer's argument, based as it is on revocability, disappears.<sup>5</sup>

---

<sup>4</sup> In this connection the Tax Court observed (R. 23): "While there is no direct evidence of the precise terms of the oral cutting contract entered into between petitioner and Coast, such contract, for aught that is shown, looked immediately to the severance and removal of all timber standing upon the Sage Tract."

<sup>5</sup> For all the evidence shows, the oral agreement created a lease or some other non-revocable interest in the realty. This, however, would not imply that the taxpayer could raise the bar of the statute of frauds. This is a federal tax case, and the Code takes precedence over local law where the language clearly so indicates. *Watson v. Commissioner*, 345 U.S. 544, 551, rehearing denied, 345 U.S. 1003; *Burnet v. Harmel*, 287 U.S. 103, 110. Section 117(k)(2) speaks of a disposal of timber "under any form or type of contract." Clearly this broad language is sufficient to encompass an oral contract.

In addition, the statute of frauds, being designed to prevent a fraud by one party against another to the contract, has never been available to or against a total stranger to

But even assuming *arguendo* that the agreement created a license, and that disposal by way of license after a holding period of more than six months would qualify taxpayer for the benefits of Section 117(k) (2), the fact is that taxpayer had not held the timber for a period of more than six months prior to its disposal within the meaning of the section.

The Commissioner's position is that the statute contemplates that the taxpayer must have owned the timber for a period of more than six months *prior to the date of the contract by which it was disposed*. Inasmuch as the oral contract was entered into the same month that taxpayer acquired the timber (R. 18), the disposal took place prior to six months from acquisition, and taxpayer cannot, therefore, qualify under Section 117(k) (2).

Taxpayer contends that there was no disposal until the timber was cut and removed, and that for all timber removed after six months from date of acquisition, capital gains treatment is available. But the statute states that disposal of the timber must

---

the contract, such as the Commissioner, especially where the contract has been fully executed to the satisfaction of the parties thereto. *Charlotte Union Bus Station v. Commissioner*, 209 F. 2d 586, 589 (C.A. 4th); *Joseph S. Finch & Co v. Commissioner*, 23 B.T.A. 1153; *Camp v. Commissioner*, 21 B.T.A. 962. See also *Marbelite Corp. v. Commissioner*, 77 F. 2d 713 (C.A. 9th). This principle has particular reference where, as here, under local law, the oral contract is not void, but merely voidable (*O'Brien v. O'Brien*, 197 Cal. 577, 241 Pac. 861), and where once having been fully performed by both parties, the statute of frauds is no longer available as a defense even by one party to the contract against the other (*Bates v. Babcock*, 95 Cal. 479, 30 Pac. 605; *Robison v. Hanley*, 136 C.A. 2d 820, 289 P. 2d 560).

be "under" a "contract", thus clearly contemplating that the date of disposal is the date of the contract. The only contract under which the timber could have been disposed of was the oral contract of October, 1947. All removals of timber up to the date of the written contract of January 9, 1950, relate back to and were disposed of under the oral contract. Accordingly, it is of no moment that this contract may have created a revocable license. Had taxpayer revoked the license, the timber removed up to the time of revocation would have nonetheless been disposed of under the oral contract. Not having revoked the license, all of the timber cut and removed during 1948 and 1949 was disposed of under the oral contract.<sup>6</sup>

Taxpayer's theory is in direct conflict with Treasury Regulations 111, Section 29.117-8 (Appendix, *infra*), which state that—

If a taxpayer disposes of timber under any form or type of contract whereby he retains an economic interest in such timber, *the disposal under the contract shall be considered to be a sale of such timber.* \* \* \* *If the taxpayer owned the*

---

<sup>6</sup> Taxpayer notes (Br. 25) that 33,883,000 board feet were sold to A. K. Wilson Lumber Company in 1950 (R. 19). But this in no way militates against our position that the timber removed by Coast Redwood during the taxable years was disposed of by the oral agreement. Furthermore, the sales to A. K. Wilson Lumber Company came after the tax years here in dispute and after the new contract of January 9, 1950. It should also be kept in mind, in this regard, that Mr. A. K. Wilson was president not only of taxpayer corporation, but of Coast Redwood and A. K. Wilson Lumber Company as well. (R. 51-52.)

*timber for a period of more than six months prior to the date of such contract, for the purposes of section 117(j) such timber shall be considered to be property used in the trade or business for the taxable year for which it is considered to have been sold, \* \* \*. (Italics supplied.)*

It is seen that the Regulations construe the statute as meaning that the disposal takes place at the date of the contract, and that a taxpayer claiming the benefit of the section must have owned the timber for more than six months "prior to the date of such contract." This construction, being in complete harmony with the language of the statute, is most certainly reasonable, and should be approved. *Commissioner v. Wheeler*, 324 U.S. 542, 546, rehearing denied, 325 U.S. 892; *Universal Battery Co. v. United States*, 281 U.S. 580, 584; *Brewster v. Gage*, 280 U.S. 327, 336. Indeed, the Tax Court, in *Springfield Plywood Corp. v. Commissioner*, 15 T.C. 697, 703, said that this regulation is "reasonable and valid", and Congress, as we will show below, after giving express consideration to the *Springfield Plywood Corp.* decision, approved the Tax Court's construction that timber removed under a cutting license is disposed of at the date of the contract.

In the *Springfield Plywood* case, *supra*, the taxpayer acquired certain timber in January, 1943. On May 14, 1943, before the expiration of six months, the taxpayer entered into an agreement with the D. & W. Lumber Company, which agreement was described therein as "the cutting licence." The Lum-

ber Company's rights were described therein as the "right and license to enter upon the land and cut and log the timber." Elsewhere the agreement provided that upon default in payment, "the right and license hereby granted to enter upon said lands and cut said timber" were to be suspended until the default was cured. The question as framed by the court was (15 T.C., p. 701) :

Did the contract dispose of the timber, or was it disposed of only when cut and removed?

In a well-considered opinion, reviewed by the court, the Tax Court upheld Section 29.117-8 of Regulations 111, and held that the "cutting license" disposed of the timber on the date the parties entered into the agreement, and, therefore, capital gains treatment was unavailable.

It is true that the Tax Court thought there had been a sale on May 14, 1943, when the contract with the lumber company was agreed upon,<sup>7</sup> but contrary to the inference taxpayer draws (Br. 25), that was not the sole ground for the decision. The argument had been advanced that the contract was only a license to cut, and that, therefore, there was no disposal until the timber was cut and removed. In answer, and as a distinct ground for the decision, the Tax Court said that even if the May 14, 1943, agreement was not a sale (thus tacitly assuming a license), "in our opinion within the statute and with-

---

<sup>7</sup> The agreement also referred to the lumber company as "vendee" and the taxpayer as "vendor."

ing a reasonable and valid regulation, disposal took place on that date." 15 T.C., p. 703.

The *Springfield Plywood* case came to the attention of Congress at its next session, and the Senate Finance Committee recommended that Section 117 (k) (2) be amended to change the law of the case (S. Rep. No. 781, Part 2, 82d Cong., 1st Sess., p. 44 (1951-2 Cum. Bull. 545, 575)):

Your committee has added a provision to section 117(k) (2) to the effect that the date of the disposal of the coal or timber shall be deemed to be the date such coal is mined or such timber is cut, rather than the date of the royalty contract as it was held in *Springfield Plywood Corporation* (15 T.C. No. 91 (1950)).

However, after consideration by the Conference Committee, the proposed amendment was discarded, as is evidenced by the following discussion on the Senate floor (Senate Discussion on Report of Conference Committee, 97 Cong. Record, Part 10, p. 13435):

Mr. GEORGE. \* \* \* the present method for computing the holding period in the case of timber subject to the provision of section 117(k) (2) is retained. Under the present law the holding period runs only to the date of the contract for disposal of the timber, instead of the date of the cutting of the timber as under the bill. \* \* \*

\* \* \* \* \*

Mr. MAGNUSON. That means, in effect, that there is no change at all.

Mr. GEORGE. There is no change at all from the present law so far as timber is concerned.

Similarly, in the House (See House Discussion on Report of Conference Committee, 97 Cong. Record, Part 10, p. 13628) :

Mr. DOUGHTON. \* \* \* (a) Holding period for timber: the present method for computing the holding period in the case of timber subject to the provisions of section 117(k) (2) would be retained. Under the present law the holding period runs only to the date of the contract for disposal of the timber, instead of the date of the cutting of the timber as under the bill.

Here is indisputable proof that the Tax Court, in holding that the date of disposal of timber cut under a cutting license is the date the contract is entered into, properly construed Section 117(k) (2) in accordance with the intent of Congress. Furthermore, in the course of considering revising Section 117(k) (2), Congress was expressly aware of the interpretation placed on the section by the Internal Revenue Bureau, as expressed in Regulations 111, Section 29.117-8. Since ultimately no revision of the section was made, Congress must be considered as having approved the Bureau's interpretation. *Helvering v. Winmill*, 305 U.S. 79, 82; *Helvering v. Reynolds Co.*, 306 U.S. 110, 115; *United States v. Armature Exchange*, 116 F. 2d 969, 971 (C.A. 9th), certiorari denied, 313 U.S. 573.

Inasmuch as taxpayer had not held the timber for a period of more than six months prior to disposal within the meaning of Section 117(k) (2), it does not qualify for capital gains treatment, but must report the amounts in question as ordinary income under Section 22(a) of the 1939 Code. (Appendix, *infra*.)



## II

**The Revised Estimate of Board Feet of Timber,  
Made In 1954, Cannot Be Applied Retroactively To  
Adjust Taxpayer's Depletion Allowance For 1948  
and 1949**

It should be noted at the outset that if it be decided that taxpayer is entitled to capital gains treatment, there is no issue concerning computation of depletion, as none would be allowable. Regulation 111, Section 29.23(m)-1 (Appendix, *infra*). In determining the capital gain, taxpayer would be allowed full recovery of the cost of the timber. Section 113 (a) and (b) of the Internal Revenue Code of 1939 (Appendix, *infra*); Regulations 111, Section 29.117-8. The Code does not permit a taxpayer who has been accorded capital gains treatment to again deduct as depletion expense the same costs which have already been recovered tax free. *Helvering v. Elbe Oil Land Co.*, 303 U.S. 372, 375-376; *Anderson v. Helvering*, 310 U.S. 404, 408-409.

Assuming, however, that the Tax Court was correct in holding that taxpayer disposed of the timber before having held it for a period of more than six months, and is not, therefore, entitled to capital gains treatment, taxpayer is entitled to deductions for depletion. Section 23(m) of the 1939 Code (Appendix, *infra*); Regulations 111, Section 29.23(m)-1. The problem here is whether taxpayer, having discovered in 1954 that the original estimate of standing timber was overstated, may apply the revised estimate retroactively to adjust upward the depletion deductions for the tax years involved.

The relief which taxpayer seeks is clearly prohibited by the Code, and contrary to taxpayer's assertions, the Regulations are in complete harmony with the Code. The regulation and case which taxpayer relies upon are directed to an entirely different problem from the problem facing the Court, as we shall explain in due course.

The pertinent portion of Code Section 23(m) reads as follows:

In any case in which it is ascertained as a result of operations or of development work that the recoverable units are greater or less than the prior estimate thereof, then such prior estimate (but not the basis for depletion) shall be revised and the allowance under this subsection *for subsequent taxable years* shall be based upon such revised estimate. \* \* \* (Italics supplied.)

There is no possible way that the phrase "for subsequent taxable years" can be construed under the facts of this case so as to allow the revised estimate to be applied to taxable years prior to the revision. The legislative history conforms entirely to the language of the statute and shows conclusively that the revised estimate is to be applied prospectively only. See S. Rep. No. 665, 72d Cong., 1st Sess., p. 16 (1939-1 Cum. Bull. (Part 2) 496, 507-508.) Similarly the Regulations conform exactly to the language of the statute (Regulations 111, Section 29.23(m)-26 (Appendix, *infra*)), stating that where it is subsequently ascertained that there are more or less units of timber remaining than the original estimate indicates,

then the original estimate (but not the basis for depletion) shall be revised and the annual depletion allowance with respect to the property *for subsequent taxable years* shall be based upon the revised estimate. (Italics supplied.)

The Fifth Circuit had the occasion to construe Section 23(m) in *Petit Anse Co. v. Commissioner*, 155 F. 2d 797, and its decision is direct authority for our position. It was held that the Commissioner could not apply a depletion rate, based upon a revised estimate, retroactively to tax years prior to the date of revision.<sup>8</sup> The court emphasized (p. 799) that the statute provides that the allowance under the revised estimate would be “for subsequent taxable years” only. The court concluded that (pp. 798-799)—

We interpret this statute [Section 23(m)] to mean that the revision for depletion *when discovered* as a result of operations or development work will be only as to the allowance for depletion in subsequent taxable years, and that there would be no retroactive revision of the depletion

---

<sup>8</sup> We would point out that in the *Petit Anse* case the Commissioner did not urge as a general rule that a revision might be applied retroactively. The Commissioner’s position was that the taxpayer had discovered, prior to the tax years involved, the facts requiring a revision, and that the revision should occur as of the time of the discovery rather than some subsequent date when the taxpayer elected to make known the facts. The court held against the Commissioner because in its view there was no evidence to support a factual finding that the taxpayer had discovered the excesses before the tax years. Compare *Beck v. Commissioner*, 15 T.C. 642, affirmed, 194 F. 2d 537 (C.A. 2d), discussed *infra*.

allowance for the years before the discovery of the existence of recoverable units in excess of the prior estimate.

Similarly in *McCahill v. Helvering*, 75 F. 2d 725, the Eighth Circuit rejected a taxpayer's attempt to apply a revised rate retroactively to 1929 and 1930. The court had this to say (p. 728):

where revision is made on account of "information subsequently obtained," the government cannot go back into the prior years and recover the excessive deductions, and neither can the taxpayer go back to the years 1929 and 1930, before the error was known, and, by obtaining deductions for those years, upset the basis for depletion as it stood in those years.

Accord: *Kehota Mining Co. v. Lewellyn*, 28 F. 2d 995 (W. D. Penn.), affirmed, 30 F. 2d 817 (C.A. 3d).

As the Tax Court pointed out (R. 26-27), the case of *Beck v. Commissioner*, 15 T.C. 642, affirmed, 194 F. 2d 537 (C.A. 2d), does not conflict with the general scheme of Section 23(m). There the taxpayer was aware of facts which would have required a downward revision of the depletion deduction for the years 1938 through 1941, but did not come forward with the facts. Subsequent to the tax years the Commissioner discovered the facts and proceeded to revise the depletion allowance for the years involved. In an opinion upheld by the Second Circuit, the Tax Court approved the Commissioner's action, saying (p. 660):

The statute contemplates no controversy as to when the ascertainment was made. It implies that the taxpayer himself, under our system of

self-levy, makes the correct adjustment when he himself ascertains the need for correction in depletion rate. The statute does not imply that the party to whom it would be an immediate tax-wise advantage to suppress the information of a need for adjustment, has any privilege not to come forward and make the necessary correction in the return. \* \* \*

By no possible interpretation of the statute can it be said that it is the duty of the Government to ferret out the fact that a correction in depletion is in order. \* \* \*

The meaning of the *Beck* decision is that the revision will be deemed to have been made as of the date that the taxpayer ascertains facts requiring a downward revision. Under our system of self-assessment, a taxpayer cannot claim an unfair advantage arising from his own silence where he had a clear duty to speak. See footnote 8, *supra*.

It is of no moment whether the taxpayer in the instant case became aware of the error in the original estimate before or after the tax years. Even if taxpayer knew of the overrun prior to the tax years, but remained silent in order to see what tax course future events might suggest, it could not now be claimed that the information was known all the time thus requiring a retroactive revision. Under such facts, the election to set the date of revision back to the date of discovery should obviously be with the Commissioner. See *Maletis v. United States*, 200 F. 2d 97, 98 (C.A. 9th).

But in any event, the record is quite clear, as the Tax Court observed (R. 27), that before 1952,

neither the taxpayer nor the Commissioner suspected that the prior estimate was wrong. That being the case, the general principle enunciated in Section 23(m) is fully applicable, and taxpayer cannot be allowed a retroactive depletion adjustment. *Petit Anse Co. v. Commissioner, supra; McCahill v. Helvering, supra.*

Taxpayer has made no attempt to reconcile its position with the critical language of Code Section 23(m), and indeed, as we have shown and the cases hold, such position is irreconcilable with the Code and with Section 29.23(m)-26 of Regulations 111.

Instead, taxpayer's position is based on a different section of the Regulations which it is claimed authorizes a retroactive application. But we submit that taxpayer's reliance on Section 29.23(m)-22 of Regulations 111 (Appendix, *infra*) is entirely misplaced. That section has no reference to the problem with which we are dealing.

Section 29.23(m)-22 refers to the matter of *re-valuation* of the basis of timber property, as opposed to a redetermination of the *quantity* of timber with which Code Section 23(m) and Section 29.23(m)-26 of Regulations 111 are concerned. Ordinarily the basis, for gains purposes, as well as for depletion purposes, is the adjusted cost of the property. See Sections 23(n), 113(a) and (b), 114(b) of the 1939 Code (Appendix, *infra*). However, there are instances where market value is to be used as the basis. Thus in the case of property acquired before March 1, 1913, if the cost basis is less than the fair market value as of March 1, 1913, the latter is

to be used as the basis. Section 113(a)(14), 1939 Code (Appendix, *infra*). See also Section 114(b)(2) of the 1939 Code relating to discovery value in the case of mines.

Unlike cost basis where a taxpayer knows at the outset how much he paid, value basis is often uncertain, and revaluation may subsequently be in order. In recognition of the uncertainties attendant upon the use of value basis, Section 29.23(m)-22 allows a revaluation of timber property under certain prescribed conditions, namely, "in the case of misrepresentation or fraud or gross error as to any facts known on the date as of which the valuation was made." But revaluation of timber property is an entirely different matter from that of revising the number of depletive units. A revaluation changes the total depletion to be allowed over the life existence of the wasting asset. A revision of the number of units, on the other hand, leaves the total depletion allowance intact and merely reallocates the deduction per unit. Nothing contained in Section 29.23(m)-22 can be taken as having any application to the matter or revision of units, which revision Code Section 23(m) expressly directs must only be applied prospectively. For that matter, Section 29.23(m)-22 refers the taxpayer specifically to Section 29.23(m)-26 for the procedure and rules applicable to a revision of the remaining depletive units. The last sentence of Section 29.23(m)-22 reads:

The depletion unit should be changed when a revision of the remaining number of units of recoverable timber in the property has been made

*in accordance with section 29.23(m)-26.* [Italics supplied.]

It may be that there was gross error in the original estimate. But such a conclusion does not dispose of this case. For that matter, taxpayer need not prove gross error at all to have a revision. Section 29.23 (m)-26 allows revision for a number of reasons, all less difficult to prove than the misrepresentation, fraud, or gross error under Section 29.23(m)-22. Thus the original estimate may be revised for subsequent taxable years under any of the following conditions:

\* \* \* the result of the growth of the timber, of changes in standards of utilization, of losses not otherwise accounted for, of abandonment of timber, or of operations or development work  
\* \* \*

The Seventh Circuit case on which taxpayer relies (*Rust-Owen Lumber Co. v. Commissioner*, 74 F. 2d 18), is not pertinent because, as is even made clear from the excerpts therefrom quoted by taxpayer (Br. 33-35), the court was dealing with revaluation and not revision of units. Of course in that case the value of the timber was inextricably tied to the number of units inasmuch as the total aggregate value was the product of the estimated value per unit multiplied by the number of units. But this cannot be allowed to divert attention from the basic problem in the case, that of revaluing the timber. It is in this connection that the court was compelled to inquire whether there was gross error sufficient to entitle the taxpayer to a revaluation under Article 230 of Regulations 69,



promulgated under the Revenue Act of 1926, predecessor of Section 29.23(m)-22.<sup>9</sup>

Section 23(m) clearly requires that any revision which may be made in taxpayer's depletion rate must be applied so as to recapture the remaining cost in "subsequent taxable years." The cases hold that this language means what it says, and the Regulations also adhere to the literal wording of the Code. The Tax Court was correct in rejecting taxpayer's application to apply a revised rate retroactively.

### CONCLUSION

For the reasons advanced above, the decision of the Tax Court is correct on both issues and should be affirmed.

Respectfully submitted,

CHARLES K. RICE,  
*Assistant Attorney General.*

ROBERT N. ANDERSON,  
WALTER R. GELLES,  
*Attorneys,*  
*Department of Justice,*  
*Washington, D. C.*

JUNE, 1957.

---

<sup>9</sup> We might further point out that taxpayer is unjustified in stating (Br. 33) that the taxpayer in the *Rust-Owen Lumber Co.* case was allowed to revalue its timber "as of the original date of valuation." There was no issue of retroactive application presented to the court in that case.

## APPENDIX

Internal Revenue Code of 1939:

SEC. 22. GROSS INCOME.

(a) *General Definition.*—"Gross income" includes gains, profits, and income derived from salaries, wages, or compensation for personal service, of whatever kind and in whatever form paid, or from professions, vocations, trades, businesses, commerce, or sales, or dealings in property, whether real or personal, growing out of the ownership or use of or interest in such property; also from interest, rent, dividends, securities, or the transaction of any business carried on for gain or profit, or gains or profits and income derived from any source whatever. \* \* \*

\* \* \* \*

(26 U.S.C. 1952 ed., Sec. 22.)

SEC. 23. DEDUCTIONS FROM GROSS INCOME.

In computing net income there shall be allowed as deductions:

\* \* \* \*

(m) *Depletion.*—In the case of mines, oil and gas wells, other natural deposits, and timber, a reasonable allowance for depletion and for depreciation of improvements, according to the peculiar conditions in each case; such reasonable allowance in all cases to be made under rules and regulations to be prescribed by the Commissioner, with the approval of the Secretary. In any case in which it is ascertained as a result of operations or of development work that the recoverable units are greater or less than the prior estimate thereof, then such prior estimate (but not the basis for depletion) shall be revised and the allowance under this subsection for subsequent taxable years shall be based upon such revised estimate. In

the case of leases the deductions shall be equitably apportioned between the lessor and lessee. In the case of property held by one person for life with remainder to another person, the deduction shall be computed as if the life tenant were the absolute owner of the property and shall be allowed to the life tenant. In the case of property held in trust the allowable deduction shall be apportioned between the income beneficiaries and the trustee in accordance with the pertinent provisions of the instrument creating the trust, or, in the absence of such provisions, on the basis of the trust income allocable to each.

For percentage depletion allowable under this subsection, see section 114(b), (3) and (4).

(n) *Basis for Depreciation and Depletion.*—The basis upon which depletion, exhaustion, wear and tear, and obsolescence are to be allowed in respect of any property shall be as provided in section 114.

\* \* \* \*

(26 U.S.C. 1952 ed., Sec. 23.)

### SEC. 113. ADJUSTED BASIS FOR DETERMINING GAIN OR LOSS.

(a) *Basis (Unadjusted) of Property.*—The basis of property shall be the cost of such property; except that—

\* \* \* \*

(14) *Property acquired before March 1, 1913.*—In the case of property acquired before March 1, 1913, if the basis otherwise determined under this subsection, adjusted (for the period prior to March 1, 1913) as provided in subsection (b), is less than the fair market value of the property as of March 1, 1913, then the basis for determining gain shall be such fair market value. In determining the fair market value of stock in a corporation as of March 1, 1913, due regard

shall be given to the fair market value of the assets of the corporation as of that date.

\* \* \* \*

(b) [as amended by Sec. 1, Act of July 14, 1952, c. 741, 66 Stat. 629] *Adjusted Basis*.—The adjusted basis for determining the gain or loss from the sale or other disposition of property, whenever acquired, shall be the basis determined under subsection (a), adjusted as hereinafter provided.

(1) *General rule*.—Proper adjustment in respect of the property shall in all cases be made—

\* \* \* \*

(B) in respect of any period since February 28, 1913, for exhaustion, wear and tear, obsolescence, amortization, and depletion, to the extent of the amount—

(i) allowed as deductions in computing net income under this chapter or prior income tax laws, and

\* \* \* \*

(26 U.S.C. 1952 ed., Sec. 113.)

#### SEC. 114. BASIS FOR DEPRECIATION AND DEPLETION.

\* \* \* \*

(b) *Basis for Depletion*.—

(1) *General rule*.—The basis upon which depletion is to be allowed in respect of any property shall be the adjusted basis provided in section 113(b) for the purpose of determining the gain upon the sale or other disposition of such property, except as provided in paragraphs (2), (3), and (4) of this subsection.

\* \* \* \*

(26 U.S.C. 1952 ed., Sec. 114.)

#### SEC. 117. CAPITAL GAINS AND LOSSES.

\* \* \* \*

(j) [as added by Sec. 151(b) of the Revenue Act of 1942, c. 619, 56 Stat. 798, and amended by Sec. 127(b) of the Revenue Act of 1943, c. 63, 58 Stat. 21] *Gains and Losses from Involuntary Conversion and from the Sale or Exchange of Certain Property Used in the Trade or Business.*—

(1) *Definition of property used in the trade or business.*—For the purposes of this subsection, the term “property used in the trade or business” means the property used in the trade or business, of a character which is subject to the allowance for depreciation provided in section 23(1), held for more than 6 months, and real property used in the trade or business, held for more than 6 months, which is not (A) property of a kind which would properly be includible in the inventory of the taxpayer if on hand at the close of the taxable year, or (B) property held by the taxpayer primarily for sale to customers in the ordinary course of his trade or business. Such term also includes timber with respect to which subsection (k) (1) or (2) is applicable.

\* \* \* \*

(k) [as added by Sec. 127(a) of the Revenue Act of 1943, *supra*] *Gain or Loss Upon the Cutting of Timber.*—

(1) If the taxpayer so elects upon his return for a taxable year, the cutting of timber (for sale or for use in the taxpayer’s trade or business) during such year by the taxpayer who owns, or has a contract right to cut, such timber providing he has owned such timber or has held such contract right for a period of more than six months prior to the beginning of such year) shall be considered as a sale or exchange of such timber cut during such year. In case such election has been made, gain or loss to the taxpayer shall be recognized in an amount equal to the difference between the adjusted basis for depletion of such timber in the hands of the taxpayer

and the fair market value of such timber. Such fair market value shall be the fair market value as of the first day of the taxable year in which such timber is cut, and shall thereafter be considered as the cost of such cut timber to the taxpayer for all purposes for which such cost is a necessary factor. If a taxpayer makes an election under this paragraph such election shall apply with respect to all timber which is owned by the taxpayer or which the taxpayer has a contract right to cut and shall be binding upon the taxpayer for the taxable year for which the election is made and for all subsequent years, unless the Commissioner, on showing of undue hardship, permits the taxpayer to revoke his election; such revocation, however, shall preclude any further elections under this paragraph except with the consent of the Commissioner.

(2) In the case of the disposal of timber (held for more than six months prior to such disposal) by the owner thereof under any form or type of contract by virtue of which the owner retains an economic interest in such timber, the difference between the amount received for such timber and the adjusted depletion basis thereof shall be considered as though it were a gain or loss, as the case may be, upon the sale of such timber. \* \* \*

(26 U.S.C. 1952 ed., Sec. 117.)

Treasury Regulations 111, promulgated under the Internal Revenue Code of 1939:

Sec. 29.23(m)-1. [As amended by T.D. 5413, 1944 Cum. Bull. 124] *Depletion of Mines, Oil and Gas Wells, Other Natural Deposits, and Timber; Depreciation of Improvements.*—Section 23(m) provides that there shall be allowed as a deduction in computing net income in the case of mines, oil and gas wells, other natural deposits, and timber, a reasonable allowance for depletion and for depreciation of improvements. Section 114 prescribes the bases upon which depreciation and depletion are to be allowed.

Under such provisions, the owner of an economic interest in mineral deposits or standing timber is allowed annual depletion deductions. However, no depletion deduction shall be allowed with respect to any timber which the owner has disposed of under any form of contract by virtue of which the owner retains an economic interest in such timber, if such disposal is considered a sale of the timber under section 117(k) (2) of the Code. \* \* \*

Sec. 29.23(m)-22. *Revaluation of Timber Not Allowed.*—No revaluation of a timber property whose value as of any specific date has been determined and approved will be made or allowed during the continuance of the ownership under which the value was so determined and approved, except in the case of misrepresentation or fraud or gross error as to any facts known on the date as of which the valuation was made. Revaluation on account of misrepresentation or fraud or such gross error will be made only with the written approval of the Commissioner. The depletion unit should be changed when a revision of the remaining number of units or recoverable timber in the property has been made in accordance with section 29.23(m)-26.

Sec. 29.23(m)-26. *Determination of Quantity of Timber.*—Each taxpayer claiming or expecting to claim a deduction for depletion is required to estimate with respect to each separate timber account the total units (feet board measure, log scale, cords, or other units) of timber reasonably known, or on good evidence believed, to have existed on the ground on March 1, 1913, or on the date of acquisition of the property, as the case may be. This estimate shall state as nearly as possible the number of units which would have been found present by a careful estimate made on the specified date with the object of deter-

mining 100 per cent of the quantity of timber which the area would have produced on that date if all of the merchantable timber had been cut and utilized in accordance with the standards of utilization prevailing in that region at that time. If subsequently during the ownership of the taxpayer making the return, as the result of the growth of the timber, of changes in standards of utilization, of losses not otherwise accounted for, of abandonment of timber, or of operations or development work, it is ascertained either by the taxpayer or the Commissioner that there remain on the ground, available for utilization, more or less units of timber than remain in the timber account or accounts on the basis of the original estimate, then the original estimate (but not the basis for depletion) shall be revised and the annual depletion allowance with respect to the property for subsequent taxable years shall be based upon the revised estimate.

Sec. 29.117-8 [As added by T.D. 5394, 1944 Cum. Bull. 274]. *Gain or Loss Upon the Cutting and Disposal of Timber.*—

\* \* \* \*

(b) *Gain or Loss upon the Disposal of Timber under Cutting Contract.*—If a taxpayer disposes of timber under any form or type of contract whereby he retains an economic interest in such timber, the disposal under the contract shall be considered to be a sale of such timber. The difference between the amounts received for the timber in any taxable year and the adjusted basis for depletion of the timber with respect to which the amounts were so received shall be considered to be a gain or loss upon the sale of such timber for such year. If the taxpayer owned the timber for a period of more than six months prior to the date of such contract, for the purposes of section 117(j) such timber shall



be considered to be property used in the trade or business for the taxable year for which it is considered to have been sold, along with other property of the taxpayer used in the trade or business as defined in section 117(j)(1). Whether gain or loss resulting from the disposition of the timber which is considered to have been sold will be deemed to be gain or loss resulting from the sale of a capital asset held for more than six months will depend upon the application of section 117(j) in the case of the taxpayer.

\* \* \* \*



No. 15434

In the

**United States Court of Appeals  
For the Ninth Circuit**

AH PAH REDWOOD CO., A California Corporation,  
*Petitioner,*

vs.

COMMISSIONER OF INTERNAL REVENUE,  
*Respondent.*

---

**APPELLANT'S REPLY BRIEF**

---

Petition to Review a Decision of the  
Tax Court of the United States

---

HONORABLE ERNEST H. VAN FOSSAN, *Judge*

---

KOERNER, YOUNG, McCOLLOCH & DEZENDORF,  
JAMES C. DEZENDORF,  
MARSHALL C. CHENEY, JR.,  
Eighth Floor, Pacific Bldg., Portland 4, Oregon,  
*Attorneys for Petitioner, Ah Pah Redwood Co.*

CHARLES K. RICE,  
Asst. U. S. Attorney General;

LEE A. JACKSON,  
ROBERT N. ANDERSON,  
WALTER R. GELLES

Attorneys,  
Department of Justice,  
Washington 25, D. C.  
*Attorneys for Respondent, Commissioner of Internal Revenue*

**FILED**

JUL 19 1957

PAUL P. O'BRIEN, CLERK



## SUBJECT INDEX

	PAGE
Preliminary Statement .....	1
Reply to Point I of Respondent .....	3
The oral agreement between Appellant and Coast Redwood Co. did not constitute a disposal of timber under then existing laws and regulations.	
Reply to Point II of Respondent .....	10
Appellant is entitled to increased depletion allowances for 1948 and 1949.	
Conclusion .....	12

## TABLE OF CASES

Beck v. Commissioner, 15 TC 642, Aff'd 194 F2d 537 (1952)....	11
Bendix Home Appliances v. Radio Accessories Co., 129 F2d 177 (1942) .....	7
Brooks v. Sinclair Refining Co., 139 F2d 746 (1944) .....	7
Curtiss Candy Co. v. Silberman, 45 F2d 451 (1930).....	6
Eldorado Ice & Planing Mill Co. v. Kinard, (1910) 96 Ark 184 131 SW 460 .....	4
Springfield Plywood Corp. v. Commissioner, 15 TC 697 (1950)	8
Willard, Sutherland & Co. v. U.S., 262 U.S. 489 67 L Ed 1086, 43 S Ct 592 (1923) .....	5

## STATUTES AND OTHER AUTHORITIES

26 ALR 2d 1139 .....	5
46 Am Jur 236, Sales § 47.....	4
1939 IRC § 117 (j) .....	2
1939 IRC § 117 (k) (2) .....	2, 3, 7
26 USCA § 631 (b) .....	2
26 USCA § 1231 (b) .....	2



In the  
**United States Court of Appeals**  
**For the Ninth Circuit**

---

AH PAH REDWOOD CO., A California Corporation,  
*Petitioner,*

vs.

COMMISSIONER OF INTERNAL REVENUE,  
*Respondent.*

---

**APPELLANT'S REPLY BRIEF**

---

Petition to Review a Decision of the  
Tax Court of the United States

---

HONORABLE ERNEST H. VAN FOSSAN, *Judge*

---

**PRELIMINARY STATEMENT**

Respondent does not question Appellant's contention that the record does not support a finding that it was engaged in the trade or business of selling timber or that the timber in controversy was held primarily for sale to customers in the ordinary course of business. Furthermore, Respondent has announced that Appellant would be entitled to capital gains treatment of all income received by it from sales of timber cut from the property in question, regardless of whether said

timber was held primarily for sale to customers in the ordinary course of business, provided that the other terms of the statute (1939 IRC § 117 (j) and 1939 IRC § 117 (k) (2), now 26 USCA § 1231 (b) and 26 USCA § 631 (b), respectively) are satisfied (Resp. Br. 9-10).

Because of the importance of the opinion entered by the Tax Court in this case, and its subsequent effect on the entire timber industry<sup>1</sup>, Appellant respectfully urges this court to definitely set forth, in its opinion of this case, a statement to the general effect that, notwithstanding a statement of the Tax Court to the contrary, a taxpayer is entitled to capital gains treatment of income derived from the disposal of timber, under the provisions of § 117 (j) and § 117 (k) (2), Internal Revenue Code of 1939, without regard to the nature of the taxpayer's business or the purpose for which the timber is held, provided the taxpayer satisfies the other requirements set forth in the statutes cited.

---

<sup>1</sup> See 35 Taxes 343 (May, 1957) Confusion under Timber Provisions of Sections 631 and 1231.



**REPLY TO POINT I OF RESPONDENT**

**The oral agreement by the Appellant and Coast Redwood Co. did not constitute a disposal of timber under the then existing laws and regulations.**

The Stipulated facts regarding the agreement in question provide the following (R. 18):

“Shortly after this purchase, taxpayer, in October, 1947, under an oral or implied contract with Coast Redwood, allowed the latter to begin cutting timber from the Sage Tract and pay therefor \$5.00 per thousand feet as removed.”

The statute in question, 1939 IRC § 117 (k) (2), provides in part:

“In the case of the disposal of timber (held for more than six months prior to such disposal) by the owner thereof *under any form or type of contract* by virtue of which the owner retains an economic interest in such timber, \* \* \*” (emphasis supplied)

In his Brief, Respondent fails to distinguish an elementary principle of contract law which, upon the facts of record, is determinative of the question before the Court.

Respondent rests his argument upon the basic assumption that the agreement referred to above constituted a “disposal” of the timber upon the date of

said agreement, because it was a form or type of contract referred to in the statute. Yet the very terms of the stipulation refute this contention.

*There can be no contract without mutuality of obligation. There can be no contract without consideration. There can be no contract without offer and acceptance.*

The facts of record, as agreed upon by Respondent, establish that Coast Redwood Co. was *permitted* to cut timber from the lands in controversy and to pay for such timber *as cut and removed*. Patently, Coast Redwood Co. was not required to remove any timber, and until timber was removed, *there was no obligation owed by Coast Redwood Co. to Appellant.*

In 46 Am Jur 236, Sales § 47, there appears this statement:

“It is settled law that a mere offer to buy or sell, until accepted by the person to whom such offer is made, imposes no obligation upon either party.”

In *Eldorado Ice & Planing Mill Co. v. Kinard* (1910) 96 Ark 184 131 SW 460, it was held that mutuality of contract means that an obligation must rest on each party to do or permit to be done something in consideration of the act or promise of the other and

therefore neither party is bound unless both are bound. *A contract which leaves it entirely optional with one of the parties as to whether or not he will perform his promise is not binding upon the other.* This rule has been generally followed in all courts. See the cases collected in an annotation at 26 ALR 2d 1139.

This general rule has been repeatedly applied by the Federal Courts.

In *Willard, Sutherland & Co. v. U. S.*, 262 U.S. 489, 67 L Ed 1086, 43 S Ct 592 (1923), there was a contract providing that the government, depending upon its own choice, might call for whatever amount of coal the Government decided to buy from the contractor. The contract provided “\* \* \* the contractor will furnish any quantity of the coal specified (i.e., of the kind and quality specified) that may be needed . . . irrespective of the quantities stated, *the government not being obligated to order any specific quantity . . .*,” and that the stated quantities ‘are estimated and are not to be considered as having *any bearing* upon the quantity which the government may order under the contract \* \* \*.’ In holding the contract void for want of mutuality, the Court said:

“There is nothing in the writing which requires the government to take, or limited its demand to, any ascertainable quantity. It must be held that, for lack of consideration and mutuality, the contract

was not enforceable. *Cold Blast Transp. Co. v. Kansas City Bolt & Nut Co.* 57 L.R.A. 696, 52 C.C.A. 25, 114 Fed. 77, 81; *Fitzgerald v. First Nat. Bank*, 52 C.C.A. 276, 114 Fed. 474, 478; *A. Santaella & Co. v. Otto F. Lange Co.* 84 C.C.A. 145, 155 Fed. 719, 721, et seq.; *Golden Cycle Min. Co. v. Rapson Coal Min. Co.*, 112 C.C.A. 95, 188 Fed. 179, 182, 183.”

In *Curtiss Candy Co. v. Silberman*, 45 F2d 451 (1930), Plaintiffs, who were jobbers, agreed with defendant to undertake exclusive distribution of defendant's product in a specified area. In holding the agreement void for want of mutuality, the Court said:

“Standing orders were placed, and from time to time modified, and shipments were periodically made thereunder; but neither orally, nor by the original or standing orders, nor through correspondence, did the parties enter into a definite agreement binding the defendant to furnish in the future, or the plaintiffs to buy, any specific quantity, or to maintain the relationship for any given period of time, or fixing prices, terms, etc. Recovery was based solely upon a breach of the alleged contract for exclusive representation. Considered as one of the covenants in, and as an integral part of, the broader contract for the marketing of defendant's products, the grant of exclusive territory must fail with the unenforceability of such marketing contract. Matters of quantity, type of merchandise, price, and other items being left undetermined, the negotiations of the parties can at best be considered as resulting in a series of separate and independent sales, each complete in itself, and each consisting of its individual order, accepted and the sale completed on the part of defendant by delivery of the merchandise. There was undoubtedly a mutual

expectation of an indefinite continuance of this relationship, but the contract lacked that mutuality necessary to make it enforceable in so far as executory obligation was concerned. *Willard Co. v. U. S.*, 262 U.S. 489, 493, 43 S.Ct. 592, 67 L.Ed. 1086; *Wakem & McLaughlin v. Culver*, 28 F.(2d) 942 (C.C.A. 6); *Am. Merch. Marine Ins. Co. v. Letton*, 9 F.(2d) 799 (C.A.A. 2); *International Shoe Co. v. Herndon*, 135 S.C. 138, 133 S.E. 202, 45 A.L.R. 1192.”

See also *Bendix Home Appliances v. Radio Accessories Co.*, 129 F2d 177 (1942), and *Brooks v. Sinclair Refining Co.*, 139 F2d 746 (1944).

Here there is no record whatever of any agreement requiring Coast Redwood Co. to cut or purchase or remove any timber from the lands in question. *The agreement of October, 1947, places no obligation upon Coast Redwood Co.* It is, therefore, an agreement void for want of mutuality.

Respondent contends that Appellant must establish that the timber was sold under the provisions of 1939 IRC § 117 (k) (2) (Resp. Br. 10). However, if, as to timber cut and removed by Coast Redwood Co. subsequent to April, 1948, Respondent relies upon an earlier disposal, it is for Respondent to establish that such a disposal was made. This Respondent has not and cannot do, and having failed to establish such contract, his entire argument fails.

The statute does not refer to a written contract. It states "under any form or type of contract." This includes a unilateral contract, which becomes binding upon performance of acts by the offeree. Here the act required was the cutting and removal of the timber. Only at that time did any obligation of Coast Redwood Co. to Appellant arise. Prior to cutting and removal by Coast Redwood Co., Appellant, at its discretion could withdraw permission to cut, alter the price of timber not yet cut, or impose any other condition it might desire.

The case upon which Respondent relies to establish that there has been a disposal within the terms of the statute is *Springfield Plywood Corp. v. Commissioner*, 15 TC 697 (1950) (Resp. Br. 13-15). Without arguing the merits of that decision, Appellant submits that the case is clearly distinguishable upon its facts from the case at bar.

The opinion clearly reflects that in the *Springfield* case there was a valid contract executed by the parties, and by its terms the contract provided for complete disposal of the timber within a fixed period. The Court said (at page 699):

"\* \* \* that cutting and removal of timber should commence by June 1, 1943, and proceed continuously, except for causes beyond vendees' control, at the rate of 45,000 feet per day, 'the cutting

license hereby granted' to terminate 2 years from the date of contract; \* \* \* 'this agreement shall not become effective until and unless' within 20 days from the date thereof the vendees should execute to the vendor a performance bond or deposit \$5,000 or execute to the vendor a chattel mortgage for \$5,000 upon property worth \$10,000, to insure performance of the agreement; that injury to or destruction of any of the timber, whether cut or uncut, by fire or the elements or otherwise should be at the vendees' risk, they to make full payment for the timber notwithstanding such loss or damage; \* \* \* that 'it is the intent of this contract that the vendee shall purchase and pay for all the standing and down timber on said lands on or before two years hereof' and that if at the expiration of that period 'any timber agreed to be purchased' shall not have been cut, removed and paid for, the amount of such timber shall be determined and the vendees shall pay therefor at the prices specified, but without any right of removal thereof; \* \* \* that the vendees agree that it is a condition of the contract and the cutting license granted that they will pay all taxes upon the real property until they have cut, removed and paid for the timber agreed to be purchased; \* \* \*"

The authorities cited indicate that the agreement in the *Springfield* case constitutes an enforceable contract; *such is not the case in the agreement between Appellant and Coast Redwood Co.*

It is therefore apparent that there being no contract, of any nature or type, there cannot be a disposal of the timber in October, 1947, under the terms of the

statute. There is no form or type of *contract* for disposal of timber, binding in the present and future and not subject to the complete right in the seller to terminate it at any time.

Logic therefore forces the conclusion that separate sales of the timber occurred as the timber was cut and removed by Coast Redwood Co. Since there is no earlier contract of disposal to which the sales can relate, amounts received by Appellant subsequent to April, 1948, were properly reported as long-term capital gains, under contracts completed by the acts of cutting and removal by Coast Redwood Co.

Appellant's returns are correct. The judgment of the Tax Court must be reversed.

## II

**Appellant is entitled to increased depletion allowances for the years 1948 and 1949.**

Respondent's statement (Resp. Br. 17) that no issue exists concerning depletion, if Appellant is entitled to capital gains treatment on the transactions in question, is incorrect. Respondent ignores the difference between ordinary income and capital gains tax rates.

If Appellant is entitled to capital gains treatment, then under its theory, no contract for disposal arises



until the timber is cut and removed by Coast Redwood Co. Until the date of actual disposal Appellant is entitled to increased depletion allowances. Appellant seeks only recovery of its capital investment, and not, as Respondent contends (Resp. Br. 17), a double deduction.

Respondent argues (Resp. Br. 21) that a downward revision of depletion allowance becomes effective on the date when the taxpayer has or should have ascertained that such revision was necessary, but when an upward revision is required, only the Commissioner is to ascertain the date of adjustment. It is obvious that the regulations do not contemplate a double standard for determination of depletion allowances and the date of adjustment thereof.

A distinction must be made between minerals that are below the ground and invisible, and are therefore of uncertain quality and amount, and timber which lies above the ground and is visible and available for determination of quality and amount. Here the years in question are open to adjustment, and under the authority of *Beck v. Commissioner*, 15 TC 642, Aff'd 194 F2d 537 (1952), the adjustment of such allowances is to be made at the time when Appellant first knew or *should have known* of the discrepancy in the amounts of timber available for depletion.

Here the depletion allowance will be increased. However, the facts should have been known to Appellant and Respondent during the years in question, and Respondent cannot now be allowed to complain if the resulting adjustment is upward instead of downward.

Appellant's claim for adjustment of depletion allowance during the years 1948 and 1949 is justified. The adjustment is authorized by law. The decision of the Tax Court must be reversed.

### CONCLUSION

The authorities presented by Appellant clearly entitle it to the relief which it seeks. Appellant is entitled to capital gains treatment on amounts received from Coast Redwood Co. for timber sold during 1948 and 1949. It is entitled to adjusted depletion allowances for its timber held until the date of disposal. The judgment of the Tax Court of the United States must be reversed.

Respectfully submitted,

KOERNER, YOUNG, McCOLLOCH &  
DEZENDORF,

JAMES C. DEZENDORF,

MARSHALL C. CHENEY, JR.,

*Attorneys for Petitioner.*

IN THE  
United States Court of Appeals  
For the Ninth Circuit

---

AH PAH REDWOOD Co., a Corporation, *Petitioner*

v.

COMMISSIONER OF INTERNAL REVENUE, *Respondent*

---

On Petition for Review of the Decision of the Tax Court  
of the United States

---

MOTION FOR PERMISSION TO FILE SUPPLEMENTAL  
BRIEF AND SUPPLEMENTAL BRIEF FOR  
THE RESPONDENT

---

CHARLES K. RICE  
*Assistant Attorney General*

LEE A. JACKSON  
ROBERT N. ANDERSON  
WALTER R. GELLES

*Attorneys*  
*Department of Justice*  
*Washington 25, D. C.*

**FILED**

AUG - 6 1957

PAUL P. O'BRIEN, CLERK

---



## INDEX

	Page
Respondent's motion for permission to file supplemental brief	1
Supplemental brief for the respondent .....	2
Argument:	
The oral agreement constituted an enforceable contract. In any event, even if the timber was disposed of by contract on the date of removal, under such contract taxpayer retained no economic interest in the timber ....	2
Conclusion .....	2
Appendix .....	7

## CITATIONS

### CASES:

<i>Gensinger v. Commissioner</i> , 208 F. 2d 576 .....	4
<i>Iowa Bridge Co. v. Commissioner</i> , 39 F. 2d 777 .....	4
<i>Jones v. Helvering</i> , 74 F. 2d 214 .....	4
<i>Nelson v. United States</i> , 131 F. 2d 301 .....	4
<i>Norfolk Nat. Bank of C. and T. v. Commissioner</i> , 66 F. 2d 48	4

### STATUTE:

Internal Revenue Code of 1939, Sec. 117 (26 U.S.C. 1952 ed., Sec. 117) .....	2, 5
--	------

### MISCELLANEOUS:

Restatement of the Law of Property (1944), Sec. 519 ....	2
--	---

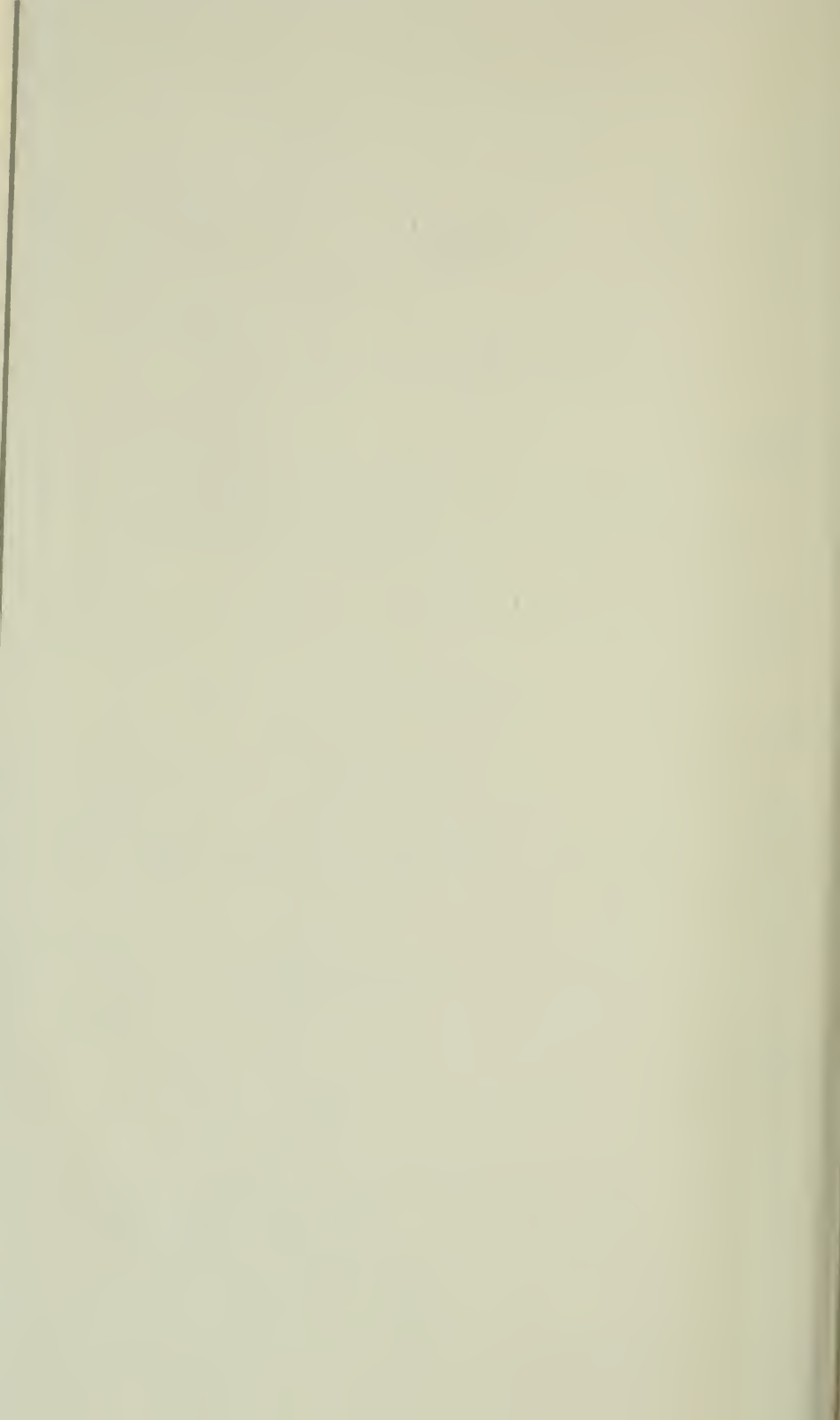

IN THE  
United States Court of Appeals  
For the Ninth Circuit

---

No. 15434

---

AH PAH REDWOOD Co., a Corporation, *Petitioner*

v.

COMMISSIONER OF INTERNAL REVENUE, *Respondent*

---

On Petition for Review of the Decision of the Tax Court  
of the United States

---

RESPONDENT'S MOTION FOR PERMISSION TO  
FILE SUPPLEMENTAL BRIEF

---

The Commissioner hereby moves this Court for permission to file this supplemental brief due to the fact that taxpayer, in its reply brief, has altered the position adopted by it in its opening brief, and thereby raises an argument not foreseeable by the Commissioner when he prepared his answering brief.

CHARLES K. RICE

*Assistant Attorney General*

AUGUST, 1957

**SUPPLEMENTAL BRIEF FOR THE RESPONDENT****ARGUMENT****The Oral Agreement Constituted an Enforcible Contract. In Any Event, Even if the Timber Was Disposed of by Contract on the Date of Removal, Under Such Contract Taxpayer Retained No Economic Interest in the Timber**

Taxpayer's entire argument in its opening brief concerning the holding period [Point C, Br. 24-30] presupposes the existence of a valid contract. In fact taxpayer repeatedly refers to the oral agreement as a contract. Taxpayer's argument in its opening brief was that the oral contract constituted a licensing contract, and that, since a license in realty is revocable,<sup>1</sup> the date of disposal of any particular timber was the date when such timber was cut and removed.

We think our answering brief effectively disposes of this argument, and apparently counsel for taxpayer agrees, for taxpayer's reply brief abandons the argument that the oral contract was a licensing contract, and urges instead an entirely unrelated and inconsistent theory, that the oral agreement was not a contract at all. This theory is based on taxpayer's contention that there was no mutuality of obligation. Since the disposal under Section 117(k)(2) must be under a "contract", and since according to taxpayer's theory the oral agreement was not a contract, taxpayer concludes that there could be no disposal at the date of the oral agreement.

---

<sup>1</sup> It should be observed that, even though a contract by which a license in realty is created may be revocable, a legally unjustifiable revocation will be actionable for damages as would a breach of any other type of contract. Restatement of the Law of Property (1944), Section 519, Comment (b).



Taxpayer now claims that the permission granted under the oral agreement to cut and remove timber was merely an offer from taxpayer which was accepted by the act of performance on the part of Coast Redwood, and that, therefore, no contract was consummated until the timber was cut and removed. Presumably each act of cutting and removing timber served to execute a new and separate contract of disposal, and since most of the timber was removed after the six-month holding period, capital gains would largely be available, according to taxpayer.

The important and overriding fact which taxpayer ignores is that both parties entered into a stipulation (Appendix, *infra*) dated May 10, 1955, in which it was agreed that the oral agreement of October, 1947, was "an oral or implied contract."<sup>2</sup> The Tax Court's characterization of the oral agreement (R. 18) as "an oral or implied contract" was based upon the stipulation. The word "contract" is a word of act denoting certain legal elements, one of which is mutual obligation. By stipulating that the agreement constituted a "contract", taxpayer accepted as fact that those elements necessary to create an enforceable contract, including mutuality, were in existence. This is especially true inasmuch as the stipulation was agreed to and signed by taxpayer's counsel, who it must be assumed used the word "contract" in its legal sense

---

<sup>2</sup> The pertinent portion of the stipulation, which was not printed but which is part of the record on appeal, reads:

3. Petitioner allowed Coast Redwood Co. (an affiliate) to start cutting timber on this tract shortly after purchase and pay \$5.00 per thousand feet as removed. *This was an oral or implied contract.* (Italics supplied.)

as embodying mutually enforceable obligations on both parties.

It is, of course, apparent that the stipulation does not fully describe the terms of the contract. The Tax Court found that there was no direct evidence of the precise terms of the contract. (R. 23.) The stipulation describes in broad terms only Coast Redwood's rights, but does not define its obligations other than to pay \$5 per thousand board feet. But in view of the fact that the purpose of the stipulation was to obviate the necessity of introducing evidence to prove those matters therein agreed to, the absence of any detailed account of Coast Redwood's obligations cannot be so construed as to impeach the description of the agreement as a "contract". In the proceeding before the Tax Court, taxpayer made no attempt to amend or withdraw the stipulation, and the trial proceeded on the assumption by both parties and the Tax Court that the agreement was a "contract." The Commissioner, relying on the word "contract" as embodying a mutually enforceable agreement cannot now be prejudiced merely because the stipulation does not fully describe the terms of such contract. It is highly inappropriate for taxpayer to raise this issue for the first time at the appellate stage after having stipulated at the trial stage that the agreement was a contract. *Gensinger v. Commissioner*, 208 F. 2d 576, 579-580 (C.A. 9th); *Nelson v. United States*, 131 F. 2d 301, 304 (C.A. 8th); *Jones v. Helvering*, 71 F. 2d 214 (C.A. D.C.); *Norfolk Nat. Bank of C. and T. v. Commissioner*, 66 F. 2d 48 (C.A. 4th); *Iowa Bridge Co. v. Commissioner*, 39 F. 2d 777 (C.A. 8th).

Furthermore, taxpayer's new theory that the oral agreement was not an enforceable contract does not aid

its case in any event. To the contrary, even accepting *arguendo* taxpayer's contention that there was a lack of mutual obligation, another insurmountable barrier bars the road to capital gains treatment. Section 117(k)(2) requires for its application not only that the disposal of the timber be under a contract, but that it be under a contract "by virtue of which the owner retains an economic interest in such timber." Under taxpayer's new theory there was no disposal until the timber was removed. But since Coast Redwood was to pay a definite predetermined price for the timber at the time of its removal, payment would have been complete before it could be said that the disposal was final. It seems obvious, therefore, that at the moment of final disposal under this new theory, taxpayer would have had no claim against the timber and thus no economic interest in it. Taxpayer admits that disposal under this theory would be by way of outright sales. (Reply Br. 10.) But as vendor who has been fully paid, taxpayer could not be said to have retained any economic interest in the timber. Since the statute requires that the disposal be accompanied by the retention of an economic interest in the timber, taxpayer would not qualify under Section 117(k)(2) in any event.

**CONCLUSION**

The decision of the Tax Court was correct and should be affirmed.

Respectfully submitted,

CHARLES K. RICE

*Assistant Attorney General*

LEE A. JACKSON

ROBERT N. ANDERSON

WALTER R. GELLES

*Attorneys*

*Department of Justice*

*Washington 25, D. C.*

AUGUST, 1957

**APPENDIX**

THE TAX COURT OF THE UNITED STATES

Docket No. 50695

AH PAH REDWOOD Co., a California Corporation,  
*Petitioner,*

v.

COMMISSIONER OF INTERNAL REVENUE, *Respondent.*

**Stipulation**

IT IS HEREBY STIPULATED AND AGREED between the Commissioner of Internal Revenue and the above entitled taxpayer, by their respective undersigned attorneys, that the following facts shall be taken as true; provided, however, that this stipulation does not waive the right of either party to introduce other evidence not at variance with the facts herein stipulated or to object to the introduction in evidence of any such facts on the grounds of immateriality or irrelevancy.

1. Petitioner is a corporation incorporated under the laws of California with its mailing address at 1101 S. W. 5th Avenue, Portland, Oregon. The returns for the periods here involved were filed with the Director of Internal Revenue for the District of Oregon. During the periods here involved, petitioner used the calendar year for reporting its income.

2. Petitioner was organized in October 1947. In October, 1947, petitioner purchased all the right, title and interest of the buyer in a certain Purchase Agreement and all the timber and land covered thereby, dated December 13, 1946, between Sage Land and Lumber Company, Inc., as Seller, and Union Bond & Trust Company, as Buyer. A copy of this Agreement is attached hereto, marked Exhibit 1-A and is hereby

made a part hereof. Hereafter this Agreement will be called the "Sage Agreement".

3. Petitioner allowed Coast Redwood Co. (an affiliate) to start cutting timber on this tract shortly after purchase and pay \$5.00 per thousand feet as removed. This was an oral or implied contract.

4. On January 9, 1950, petitioner entered into a formal written Agreement with Coast Redwood Co., whereunder petitioner agreed to sell all of the timber and land covered by the Sage Agreement to Coast Redwood Co. A duplicate original copy of this agreement is attached hereto, marked Exhibit 2-B and made a part hereof.

5. In the years 1948 and 1949 here in question petitioner reported its income on the sales of timber to Coast Redwood Co. as long term capital gains.

6. In reporting its income on the timber sold to Coast Redwood Co. petitioner used the basis for depletion of \$3.941566 per thousand board feet. Respondent also used this basis in computing a portion of the deficiencies against petitioner here in question.

7. The basis for depletion, described in Paragraph 6 above, was computed by petitioner and respondent in the following manner:

In October 1947 petitioner purchased the Sage Agreement and the timber covered thereby for a purchase price of \$1,443,838.99. It was assumed by petitioner that the correct amount of the Sage timber was as is shown on Schedule A of the Sage Agreement (Exhibit 1-A) and the basis for depletion was computed by dividing the assumed quantity of timber into the total purchase price.

8. In addition to other sales, petitioner sold 33 million, 883 thousand board feet of timber covered by the Sage Agreement to A. K. Wilson Lumber Company in 1950. This quantity of timber was assumed to be

the above amount on the basis of the quantities shown in Schedule A to the Sage Agreement.

9. Prior to petitioner's acquisition of the Sage Agreement, International Pacific Pulp and Paper Co. sold 16 million 22 thousand and 60 board feet of the timber covered thereby to Coast Redwood Co. in the years 1946 and 1947.

Dated this 10th day of May, 1955.

Sgd. JAMES C. DEZENDORF  
*Attorney for Petitioner*

Sgd. JOHN P. BARNES  
John P. Barnes  
*Chief Counsel*  
*Internal Revenue Service*





No. 15434

In the

**United States Court of Appeals  
For the Ninth Circuit**

AH PAH REDWOOD CO., A California Corporation,  
*Petitioner,*

v.

COMMISSIONER OF INTERNAL REVENUE,  
*Respondent.*

**Petitioner's Showing and Brief in Opposi-  
tion to Respondent's Motion for Permis-  
sion to File Supplemental Brief and His  
Supplemental Brief**

Petition to Review a Decision of the Tax Court  
of the United States

HONORABLE ERNEST H. VAN FOSSAN, JUDGE

KOERNER, YOUNG, McCOLLOCH & DEZENDORF  
JAMES C. DEZENDORF  
MARSHALL C. CHENEY, JR.  
Eighth Floor, Pacific Bldg., Portland 4, Oregon  
*Attorneys for Petitioner, Ah Pah Redwood Co.*

CHARLES K. RICE,  
Asst. U. S. Attorney General;  
LEE A. JACKSON,  
ROBERT N. ANDERSON  
WALTER R. GELLES  
*Attorneys*  
Department of Justice  
Washington 25, D. C.  
*Attorneys for Respondent, Commissioner of Internal Revenue*

FILED

AUG 27 1957

PAUL P O'BRIEN, CLERK



## INDEX

	PAGE
Argument .....	1
Conclusion .....	8

## TABLE OF CASES

Hargraves v. Bowden (9th Cir., 1954), 217 F2d 839.....	2
Kennedy v. United States (9th Circ., 1940, 115 F2d 624.....	2
Meyer v. Territory of Hawaii (9th Circ., 1947), 164 F2d 845....	2
United States v. Gallagher et al (9th Circ., 1945), 151 F2d 556	2

## STATUTES AND OTHER AUTHORITIES

Appellant's Brief, at page 25, 28, and 29 .....	4
Corbin on Contracts, Vol. I § 157 at page 515 .....	6
1939 IRC § 117 (k) (2) .....	9
Petitioner's Original Brief (June 28, 1955) .....	3
Rule 18 of Rules of United States Court of Appeals, Ninth Circuit .....	1
Rule 15 of Rules of United States Court of Appeals, Ninth Circuit .....	1



No. 15434

In the

**United States Court of Appeals  
For the Ninth Circuit**

---

AH PAH REDWOOD CO., A California Corporation, *Petitioner,*

v.

COMMISSIONER OF INTERNAL REVENUE, *Respondent.*

---

**Petitioner's Showing and Brief in Opposition  
to Respondent's Motion for Permission to File  
Supplemental Brief and His Supplemental Brief**

---

Petition to Review a Decision of the Tax Court  
of the United States

---

HONORABLE ERNEST H. VAN FOSSAN, JUDGE

---

**ARGUMENT**

Respondent cites no authority permitting him to file a Supplemental Brief.

Rule 18 of the Rules of the United States Court of Appeals for the Ninth Circuit, pertaining to Briefs, makes no mention whatever of Supplementary Briefs.

Rule 15 of said rules provides in part:

"1. All motions to the court shall be reduced to writing, shall contain a brief statement of the facts

and objects of the motion, shall be supported by points and authorities, and, where the facts are not otherwise proved in the cause, by affidavits, and shall be served upon opposing counsel at least 5 days before the day noticed for the hearing.”

This Court has held that within their limited sphere, rules of Court have the force of law. *Meyer v. Territory of Hawaii* (9th Circ., 1947), 164 F2d 845.

This Court has also held that without good cause shown, the rules of Court will not be waived. See *Kennedy v. United States* (9th Circ., 1940), 115 F2d 624; *Hargraves v. Bowden* (9th Circ., 1954), 217 F2d 839; and *United States v. Gallagher et al* (9th Circ., 1945), 151 F2d 556.

Since Respondent has neither sought a waiver of the rules of this court, nor has he shown any basis for a waiver, Respondent’s motion must be denied.

Without waiving its objection to Respondent’s motion for permission to file a Supplementary Brief, Petitioner feels compelled to correct certain misstatements contained in Respondent’s Supplementary Brief.

Respondent contends that Petitioner has altered the position adopted by it in its opening Brief, by contending in its Reply Brief that the contract referred to in the Stipulation of Facts is void for want of mutuality.

In fact, this contention was made by Petitioner in the Briefs which were filed in the Tax Court. No matter of surprise is involved in any way.

On June 28, 1955, Petitioner filed in the Tax Court its Brief which contained the following language (at page 7):

*“B. The agreement was not a contract to sell timber. It was no more than a license to cut which ripened into a contract for the sale of logs upon severance of each tree. This cannot constitute a ‘disposal’ of timber under Section 117 (k) (2).*

*“In Springfield Plywood Corp. v. Commissioner 15 TC 697 (1950) the taxpayer purchased timber in January, 1943, and entered into a written cutting contract in May, 1943, which was held to constitute a ‘disposal’ of the timber on that date.*

*“The decision turned on the court’s finding that:*

*“‘In our view the timber involved was all sold on May 14, 1943, and only payment, as agreed, was delayed.’ (Emphasis supplied)*

*“The Court cannot find in the present case that the timber was ‘disposed of’ in October, 1947, or at any time prior to 1950 when the written contract was executed by the petitioner and Coast (Ex. 2-B). Contrary to the facts in the Springfield case:*

*“a.) The agreement did not obligate Coast to pay for timber which it did not remove.*

*“b.) Petitioner bore the fire risk throughout 1948 and 1949.*

*“c.) Petitioner sold 33,883,000 board feet to A. K. Wilson Lumber Company in 1950 (Stip. 8).*

“d.) The Agreement was unenforceable under the Statute of Frauds.

“It has never been held that a revocable cutting license which passes no interest in the timber to the licensee constitutes a ‘disposal’ of the timber within Section 117 (k) (2). Defendant erred in refusing to allow petitioner to treat income received from Coast in 1948 and 1949 as long term capital gain, since disposition of the timber factually and legally occurred more than six (6) months after its acquisition by petitioner.” (Emphasis supplied)

In Petitioner’s opening Brief filed in this Court the following statements appear (at pages 25, 28, and 29):

“The oral agreement here may be distinguished from the written agreement in the *Springfield Ply-wood Corporation* case in the following particulars:

“(a) *The agreement did not obligate Coast to pay for timber which it did not remove.*” [Emphasis supplied]

\* \* \* \* \*

“Here, the oral or implied agreement contemplated only *an oral license to cut timber as desired, with Coast required to pay only for logs removed, as removed, at a fixed price (R. 18).*”

\* \* \* \* \*

“A license in real property may be defined as a personal unassignable and ordinarily revocable privilege which may be created by parol to do one or more acts on the land without possessing any interest therein. A license is an authority to do a



lawful act which without it would be unlawful, and while it remains unrevoked, a license justifies the acts which it authorizes to be done. This is true even of a bare parol license given without consideration. 33 Am. Jur. 398 (Licenses § 91)."

\* \* \* \* \*

"The authorities are uniform in stating that an oral license to enter, cut and remove timber, is revocable by the grantor at any time as to timber remaining uncut. Therefore, there *cannot* be a 'disposal' of the timber at the time the license is granted, insofar as 1939 IRC § 117 (k) (2) is concerned."

The above quotations clearly establish that Petitioner's argument in its Reply Brief is far from new. Petitioner has emphatically contended since the beginning of this case that the contract in question was not enforceable. Petitioner urges that its Reply Brief merely carries the position which it has steadfastly maintained to an orderly and logical conclusion.

Respondent in his Supplementary Brief repeatedly refers to the use of the word "contract" in the stipulation executed by the parties on May 10, 1955. However, Respondent then contends that this stipulation constitutes an admission that all necessary elements were present to create a legally enforceable contract. *Such is not the case.*

A contract may be enforceable or unenforceable, executory or executed, unilateral or bilateral, legal or

illegal, and may or may not satisfy the requirements of mutuality.

It should be noted that in the cases cited in Petitioner's Briefs, the term "contract" is used by the Courts in referring to oral licenses to enter and cut timber given without consideration. In Corbin on Contracts, Volume I, § 157, at page 515, there appears this statement:

"In what purports to be a bilateral contract, one party sometimes promises to supply another, on specified terms, with all the goods or services that the other may order from time to time within a stated period. A mere statement by the other party that he assents to this, or 'accepts' it, is not a promise to order any goods or to pay anything. There is no consideration of any sort for the seller's promise; and he is not bound by it. *This remains true, even though the parties think that a contract has been made and expressly label their agreement a 'contract.'* In cases like this, there may be no good reason for implying any kind of promise by the offeree. Indeed the proposal and promise of the seller has the form of an invitation for orders; and the mode of making an operative acceptance is to send in an order for a specific amount. By such an order, if there has been no previous notice of revocation, a contract is consummated binding both parties. The standing offer is one of those that empowers the offeree to accept more than once and to create a series of separate obligations. The sending in of one order and the filling of it by the seller do not make the offer irrevocable as to additional amounts if the parties have not so agreed." [Emphasis supplied]

Respondent by his argument attempts to set up two standards of interpretation of the stipulation. Respondent claims the right to read into the stipulation terms which are not therein stated, but asserts that Petitioner will be required to accept Respondent's interpretation, and will not be permitted to adopt any of several alternative interpretations which are as logical as Respondent's.

If Respondent's argument concerning the application of the statute in question (1939 IRC § 117 (k) (2)) is followed to its logical conclusion, it is apparent that Respondent contends that the statute will not apply in the case of any sale where clear title to timber passes to the purchaser, since no economic interest is retained by the seller.

Respondent evidently contends that only a "partial" disposal will qualify timber sales under this statute since a complete disposal will not permit the seller to retain the economic interest required by the statute. In effect, he would nullify the operation of the statute.

The argument made by Respondent, again reflects his failure to recognize the basic principle that the term "contract" as used in 1939 IRC § 117 (k) (2) (see Appendix, *infra*) includes unilateral contracts, as specifically explained in Petitioner's Reply Brief at page 8.

Respondent's argument is without foundation, since a unilateral contract for "disposal" of the timber was reached at the moment of cutting and removal, and the statutory requirements for capital gains treatment were thereupon satisfied.

Petitioner has contended from the very beginning of this case that the "oral or implied contract" between it and the Coast Redwood Co. did not constitute a "disposal" under the terms of 1939 IRC § 117 (k) (2), nor did it constitute an enforceable contract. The failure of Respondent to meet this argument in his answering Brief is not now sufficient reason to permit him to file a Supplemental Brief in derogation of the rules of this Court.

### CONCLUSION

Respondent's Motion must be denied, and its Supplemental Brief should be stricken from the files.

Respectfully submitted,

KOERNER, YOUNG, McCOLLOCH  
& DEZENDORF,

/s/ James C. Dezendorf,  
/s/ Marshall C. Cheney, Jr.,  
*Attorneys for Petitioner,*

800 Pacific Building,  
Portland 4, Oregon.

**APPENDIX**

1939 IRC § 117 (k) (2) provides.

*“Gain or loss upon the cutting of timber*

“(2) In the case of the disposal of timber or coal (including lignite), held for more than 6 months prior to such disposal, by the owner thereof under any form or type of contract by virtue of which the owner retains an economic interest in such timber or coal, the difference between the amount received for such timber or coal and the adjusted depletion basis thereof shall be considered as though it were a gain or loss, as the case may be, upon the sale of such timber or coal. Such owner shall not be entitled to the allowance for percentage depletion provided for in section 114(b) (4) with respect to such coal. This paragraph shall not apply to income realized by the owner as a co-adventurer, partner, or principal in the mining of such coal. The date of disposal of such coal shall be deemed to be the date such coal is mined. In determining the gross income, the adjusted gross income, or the net income of the lessee, the deductions allowable with respect to rents and royalties shall be determined without regard to the provisions of this paragraph. This paragraph shall have no application, in the case of coal, for the purposes of applying section 102 or subchapter A of chapter 2 (including the computation under section 117 (c) (1) of a tax in lieu of the tax imposed by section 500).”



In the United States Court of Appeals  
for the Ninth Circuit

AH PAH REDWOOD Co., A Corporation, PETITIONER

v.

COMMISSIONER OF INTERNAL REVENUE, RESPONDENT

ON PETITION FOR REVIEW OF THE DECISION OF THE  
TAX COURT OF THE UNITED STATES

BRIEF OF AMICI CURIAE

HENRY BAHR,  
1319 18th St., N. W.,  
Washington, D. C.

CHARLES W. BRIGGS,  
W2162 First National Bank Building,  
St. Paul 1, Minnesota.

THOMAS B. STOEL,  
1410 Yeon Building,  
Portland, Oregon.

CHARLES A. STRONG,  
1021 Crocker Building,  
San Francisco, California.

LAURENS WILLIAMS,  
Ring Building,  
Washington, D. C.

*Amici Curiae*

BRIGGS, GILBERT, MORTON, KYLE & MACARTNEY,  
W2162 First National Bank Building,  
St. Paul 1, Minnesota.

HART, SPENCER, McCULLOUGH, ROCKWOOD AND DAVIES,  
1410 Yeon Building,  
522 S. W. Fifth Avenue,  
Portland, Oregon.

SUTHERLAND, ASBILL AND BRENNAN,  
Ring Building,  
Washington, D. C., and  
First National Bank Building,  
Atlanta, Georgia.

FILED

SEP - 7 1957

Of Counsel.

PAUL P. O'RIEN, CLERK





**In the United States Court of Appeals  
for the Ninth Circuit**

---

No. 15434

AH PAH REDWOOD Co., A Corporation, PETITIONER

*v.*

COMMISSIONER OF INTERNAL REVENUE, RESPONDENT

---

ON PETITION FOR REVIEW OF THE DECISION OF THE  
TAX COURT OF THE UNITED STATES

---

**BRIEF OF AMICI CURIAE**

We file this brief as *amici curiae*, at the instance of California Forest Protective Association, Western Forestry and Conservation Association, Forest Industries Committee on Timber Valuation and Taxation, and National Lumber Manufacturers' Association, representing a substantial segment of the timber industry.

The brief is filed by written consent of all parties to the case. It is addressed to a matter which is of vital concern to the entire timber industry and which has been injected into this case by inadvertence. We refer to the point of law, decided by the Tax Court through mistake, that Sections 117(j) and 117(k)(2) of the Internal Revenue Code of 1939 do not apply to the disposal of timber held for sale to customers in the ordinary course of a taxpayer's trade or business.

## Review of the Proceedings

At the outset, a short review of how this point happened to become involved in this case may be helpful to the Court.

Examination of the pleadings and briefs filed below makes it clear that the point was never put in issue by the parties below. The confusion of the Tax Court on the point apparently was a product of the practice there of filing simultaneous briefs.

In an effort to anticipate all possible argument by the taxpayer as to why capital gain was realized in the timber transaction involved in the case, in his principal brief in the Tax Court the Commissioner pointed out that "no evidence was submitted by . . . [the taxpayer] as to the purpose for which the . . . property was being held or whether such property was used in the taxpayer's trade or business." (Commissioner's Principal Brief, below, p. 14). It is perfectly clear from the context of these quoted remarks that they were designed to rebut a possible contention by the taxpayer that the timber was a *capital asset* so that capital gain would be realized under Section 117(a) of the Internal Revenue Code of 1939, even if it were determined that the transaction did not qualify for capital gain treatment under Sections 117(j) and 117(k)(2) of that Code. That this part of the Commissioner's argument was *not* directed at Sections 117(j) and (k)(2) is clearly shown by the language of the Commissioner's brief immediately following the above quotation:

"However, since it was alleged in the petition that the timber was in the nature of a capital asset (Pet. ¶ V(1)), respondent assumes that the petitioner is attempting to show that the transaction falls within the scope of the timber provisions contained in section

117(k)(1) or (2) of the Internal Revenue Code as amended by the Revenue Act of 1943. If section 117(k)(1) or (2) is applicable, the timber involved is brought within the definition of 'property used in the trade or business of the taxpayer' by section 117(j) of the Internal Revenue Code as amended by the Revenue Act of 1943, and amounts received are treated as a sale of property used in a trade or business of the taxpayer for the purpose of section 117(j).''

Judging from language in the Tax Court's opinion, we surmise that what happened was that Judge Van Fossan telescoped the Commissioner's argument on the capital gains issue, and erroneously concluded that the Commissioner's reference to the taxpayer's failure to adduce evidence of the purpose for which it held the timber was directed at Sections 117(j) and (k)(2), which as it turned out were the only provisions on which the taxpayer relied. In any event, the Judge erroneously applied the trade or business test as a separate ground for holding that the taxpayer was not entitled to capital gain treatment under Sections 117(j) and (k)(2).

As indicated by the Record, the taxpayer filed a motion in the Tax Court for revision of that court's decision with respect to the scope of Sections 117(j) and (k)(2). However, before the Tax Court acted on such motion, the taxpayer apparently felt obliged to appeal to this Court to protect its right of appeal—thus leaving its motion for revision of the Tax Court's opinion undecided.

Faced with this published Tax Court opinion holding for him on a point for which he has never contended, and which is contrary to his long-established position, the Commissioner promptly took the commendable step of expressly disavowing the Tax Court opinion on this point (Rev. Rul.

57-90, I. R. B. 1957-10, 9).<sup>1</sup> The Commissioner's statement of his position in Rev. Rul. 57-90 is forthright and unequivocal. It should settle this matter for the future.

However, we are somewhat apprehensive that the Brief for Respondent filed by the Department of Justice may prove misleading to the Court in its statement of the Government's position on this point. Respondent's Brief not only lacks the forthrightness of the Commissioner's Revenue Ruling, but is open to the possible interpretation, whether intended or not, that there is some support in prior cases for the erroneous position taken by the Tax Court that capital gain treatment is not available under Sections 117 (j) and (k)(2) where the timber disposed of was held for sale to customers in the ordinary course of business. Since the taxpayer's Reply Brief does not discuss the cases cited on this point in the Brief for Respondent, we file this brief to do so.

### Reply to Brief for Respondent

The Brief for Respondent quotes, out of context, a sentence from the opinion of the Court of Claims in *Boeing v. United States*, 98 F. Supp. 581 (Ct. Cls. 1951), in such a way as to leave the impression that the opinion lends sup-

---

<sup>1</sup>"SECTION 631.—GAIN OR LOSS IN THE CASE OF TIMBER OR COAL (Also Section 1231) Rev. Rul. 57-90

"In the case of the disposal of timber, held for more than six months prior to such disposal, by the owner thereof under any form or type of contract by virtue of which the owner retains an economic interest in such timber, pursuant to the provisions of section 631(b) of the Internal Revenue Code of 1954, the gain or loss on such disposal is subject to the tax treatment provided by section 1231 regardless of the nature of the taxpayer's business or the purpose for which the timber is held. To the extent that the opinion in *Ah Pah Redwood Co. v. Commissioner*, 26 T.C. 1197, may be inconsistent with the foregoing, it does not represent the position of the Internal Revenue Service." (Rev. Rul. 57-90, I.R.B. 1957-10, 9-10)

port to the Tax Court's erroneous position on the question.<sup>2</sup> Nothing could be farther from the truth.

Although it was decided in 1951, the *Boeing* case in the Court of Claims involved taxes for the years 1936 and 1937. The Court of Claims was very careful to point out that although Section 117(k)(2) of the Internal Revenue Code of 1939 (enacted in 1943) was made retroactive back to 1913, Section 117(j) of the 1939 Code (enacted in 1942) was *not* made retroactive beyond 1942. Thus, Section 117(k)(2) applied to the years in controversy in the *Boeing* case then before the Court of Claims (1936 and 1937), and Section 117(j) did *not* apply to the tax years involved in that case. Thus the Court of Claims was faced with the problem of interpreting Section 117(k)(2) *without* Section 117(j).

As to Section 117(k)(2) *thus standing alone*, the Court of Claims stated:

“The controlling law tells us only that (k)(2) gains are to be considered as gains upon sales of timber. It does not tell us expressly whether gains upon sales of timber are taxable as capital gains or as ordinary income. Even prior to the enactment of Section 117(k), the courts had held that the proceeds of a sale of timber to a logging company under a cutting contract were

---

<sup>2</sup> The Brief for the Respondent, in footnote 2, pages 8-9 states:

“2 In the *Boeing* case, the Court of Claims concluded, after tracing the legislative history of Section 117(k)(2), that the taxpayer was entitled to capital gains treatment on the Greenwood contract (pp. 584-585)—

“unless perhaps it can be said that plaintiff was in the trade or business of selling timber to logging companies.

The court held that the taxpayer was not in the business of selling timber, but was merely liquidating an investment and, therefore, having otherwise qualified under Section 117(k)(2), was entitled to capital gains. See also *Willey v. Commissioner*, decided December 7, 1950 (1950 P-H T.C. Memorandum Decisions, par. 50,299), affirmed, 199 F. 2d 375 (C.A. 6th); *Commissioner v. Boeing*, 106 F. 2d 305 (C.A. 9th), certiorari denied, 308 U.S. 619.”

capital gains. *United States v. Robinson*, 5 Cir. 129 F. 2d 297; *Estate of M. M. Stark*, 45 B. T. A. 882. The decision in *Commissioner of Internal Revenue v. Boeing*, 9 Cir. 106 F. 2d 305, certiorari denied 308 U. S. 619, 60 S. Ct. 295, 84 L. Ed. 517, which defendant contends estops plaintiff here and which we discuss more fully *infra*, went against taxpayer because the court concluded that the contracts did not effect sales of timber. But the law now provides that they are to be considered as if they did." (98 F. Supp. at p. 584).

In other words, as the Court of Claims correctly pointed out, all that Section 117(k)(2) provides is that certain disposals of timber shall be treated as sales. It says nothing about how such sales are to be taxed. Therefore, since Section 117(j), which gives capital gains treatment to certain sales and exchanges of certain *non-capital* assets, was not applicable to 1936 and 1937, the court had to look to Section 117(a) to determine whether the 1936 and 1937 timber disposals of the taxpayer, which were to be treated as sales under Section 117(k)(2), were sales of *capital assets*.

It was in this setting that the Court of Claims used the following language which has been so misleadingly quoted out of context in the Brief for Respondent herein:

"These, then, are capital gains unless perhaps it can be said that plaintiff was in the trade or business of selling timber to logging companies."

It is perfectly obvious that the above quoted remarks of the Court of Claims have reference only to Section 117(k)(2) standing alone without the necessary tie-in with Section 117(j). It also is perfectly obvious that whether the timber would be a capital asset under Section 117(a) would involve the factual question of whether it was held for sale to

customers in the ordinary course of business. The quoted remarks are thus no authority whatsoever for the Tax Court's opinion on the point. In fact, the full opinion of the Court of Claims in the *Boeing* case is contrary to the present Tax Court position, for the Court of Claims expressly stated that:

“If 117(j) had *also* been made retroactive back to 1913, then, of course, there would be no doubt that all (k)(2) gains would be taxable as capital gains.” (Emphasis supplied) (*Boeing v. United States*, 98 F. Supp. 581, footnote 8, at page 584)

Besides the *Boeing* case, discussed above, the Brief for Respondent also refers to a prior *Boeing* case (*Commissioner v. Boeing*, 106 F. 2d 305 (9th Cir. 1939, cert. denied 308 U.S. 619 (1939)), involving taxes for the years 1933 and 1934. What the Brief for Respondent neglects to indicate is that this prior *Boeing* case was decided in 1939. Section 117(j) was not enacted until 1942, and Section 117(k)(2) was not enacted until 1943. This Court surely could not be thought to have construed or applied, in 1939, statutes which were not enacted until 1942 and 1943! This Court's opinion in that case has no possible bearing on the question now before it.

The third case cited on this point in the Brief for Respondent is *D. H. Willey*, 9 T.C.M. 1109 (1950), aff'd, 199 F. 2d 375 (6th Cir. 1952). That case did not even involve Sections 117(j) and (k)(2). It involved only Section 117(a). The question presented was whether certain income received from the sale of timber was ordinary income under Section 22(a) or “gain from the sale of capital assets under section 117.” The Commissioner argued that it was ordinary income since it constituted receipt of income from the sale of property held primarily for sale to customers in

the ordinary course of trade or business. The Tax Court pointed out that "Property so held is excluded from the definition of 'capital assets' in section 117(a)." The case was decided against the taxpayer for failure to meet his burden of proof. The Court of Appeals for the Sixth Circuit affirmed in a *per curiam* decision which merely stated in effect that the opinion of the Tax Court was being affirmed. There is thus nothing whatsoever in the *Willey* case to justify the reference thereto in the Brief for Respondent herein.

### Legislative Construction

Since the taxpayer has briefed in detail the legislative and regulatory history of Sections 117(j) and (k)(2), there is no need for us to duplicate that effort here.

However, we do suggest that Section 117(j) is so clear on its face that there is no need to resort to its legislative history to determine its meaning. Mere reading of the Section requires the conclusion that all timber to which Section 117(k)(2) applies automatically qualifies for Section 117(j) treatment, regardless of whether such timber was held for customers in the ordinary course of trade or business.

Section 117(j)(1) contains the "Definition of property used in the trade or business" to which special capital gain and ordinary loss treatment is accorded by Section 117(j)(2). As applicable to the years in controversy in this case (1948-1949), it reads:

"(j) GAINS AND LOSSES FROM INVOLUNTARY CONVERSION AND FROM THE SALE OR EXCHANGE OF CERTAIN PROPERTY USED IN THE TRADE OR BUSINESS—(1) DEFINITION OF PROPERTY USED IN THE TRADE OR BUSINESS.—For the purposes of this subsection, *the term 'property used in the trade or business'* means the property used in the trade or business, of a character which is subject



to the allowance for depreciation provided in section 23(1), held for more than 6 months, and real property used in the trade or business, held for more than 6 months, which is not (A) property of a kind which would properly be includible in the inventory of the taxpayer if on hand at the close of the taxable year, or (B) property held by the taxpayer primarily for sale to customers in the ordinary course of his trade or business. *Such term also includes timber with respect to which subsection (k)(1) or (2) is applicable.*" (Emphasis supplied)

It is perfectly obvious that the words "Such term" in the second sentence refer only to *the term* being defined, namely, "Property used in the trade or business." It thus is clear that the "(A)" and "(B)" restrictions in the first sentence—with respect to inventories and property held primarily for sale to customers—do not apply to the second sentence, which contains the special definition of "property used in the trade or business" as respects "timber".

No other construction makes sense. If the limitations in the first sentence as to inventories and property held for sale to customers were intended to be incorporated by inference into the second sentence and thus apply to timber, the six months holding period requirement in the first sentence also would have to be deemed incorporated by inference into the second sentence and to apply to timber. This clearly was not intended, for Congress expressly provided different six month holding period rules for timber in Sections 117(k)(1) and (2) themselves. (In the case of Section 117(k)(1) the timber must have been held for more than six months *prior to the beginning of the year in which the timber is cut*. In the case of Section 117(k)(2) the timber must have been held for more than six months *prior to the disposal thereof*.) Thus any construction which applied the restrictions in the first sentence of Section 117

(j)(1) to timber to which subsection (k)(1) or (k)(2) applies would create insolvable conflicts between the six month holding period rules in 117(j)(1) and those in 117(k)(1) and (k)(2).

Furthermore, as noted, any construction which carries the inventory and property held for sale to customers restrictions of the first sentence of Section 117(j)(1) into the second sentence dealing with timber would require that such restrictions be applied to Section 117(k)(1) as well as to Section 117(k)(2), for the second sentence of Section 117(j)(1) covers "timber with respect to which subsection (k)(1) or (2) is applicable." The "B" provision of the first sentence of Section 117(j)(1) *excludes* "property held by the taxpayer primarily for sale to customers in the ordinary course of his trade or business." On the other hand, Section 117(k)(1) by its explicit terms *applies* to timber held "for sale or for use in the taxpayer's trade or business." It is thus impossible to read into the second sentence of Section 117(j)(1) the limitations as to property held for sale to customers contained in the first sentence of such paragraph without creating further insolvable conflicts between Section 117(j)(1) and Section 117(k)(1).

Similar irreconcilable conflicts with certain 1951 amendments of Section 117(j)(1) would be created by any construction which carried the property held for sale to customers in the ordinary course of business limitation of the first sentence over into the second sentence of such Section. In the Revenue Act of 1951 Congress amended the second sentence of Section 117(j)(1) by adding a new provision at the end of the sentence assuring capital gain treatment of sales of "unharvested crops". Congress also added a third sentence ensuring capital gains treatment of sales of "breeding livestock."<sup>3</sup> The Treasury Department had

---

<sup>3</sup> These amendments also added "coal" to Section 117(k)(2) and to the second sentence of Section 117(j)(1).

been contending that unharvested crops and breeding livestock were held for sale to customers in the ordinary course of business and therefore were not entitled to capital gains treatment. The Committee Reports make it clear that the purpose of these Amendments was to settle the dispute and allow capital gains treatment.<sup>4</sup> Here, again, holding period requirements *different* from the six month holding period requirement of the first sentence of Section 117 (j)(1) were provided (12 months in the case of breeding livestock, *no holding period* in the case of unharvested crops). Thus, as in the case of timber covered by 117 (k)(1) and 117(k)(2), a construction of Section 117(j)(1) which, by inference, carries the first sentence limitations and requirements into the second sentence of Section 117 (j)(1) would create an irreconcilable conflict between the first sentence and the second sentence (both before and after the 1951 amendment) and between the first sentence and the third sentence (added by the 1951 amendment). The Commissioner's construction of the statute in Rev. Rul. 57-90 avoids all these problems.

There is nothing in Section 117(k)(2) itself to prevent its application to timber held for sale to customers in the ordinary course of trade or business. As already indicated in connection with the discussion of the *Boeing* case in the Court of Claims, *supra*, in effect all that Section 117(k)(2) says is that a *disposal of timber* qualifying thereunder is to be treated as a *sale of timber*. It is Sections 117(j)(1) and (2) which provide *how* that *sale* shall be treated. Section 117(j)(1) says that Section 117(k)(2) timber is "property used in the trade or business", and Section 117(j)(2) says that a sale of "property used in the trade or business", at a gain, is to be considered as the sale of a capital asset. This is what the Tax Court opinion overlooks—and it is the

---

<sup>4</sup> Report, Senate Finance Committee (82d Congress, 1st Sess., S. Rept. 781, p. 41-42 and 47-48); Conference Committee (82d Congress, 1st Sess., H. Rept. 1213, p. 78.)

key to the whole statutory pattern of the timber provisions in Section 117.

If there were any doubt at all about the correctness of the above interpretation of Section 117(j)(1) of the 1939 Code, it is removed by the manner in which the provision was recodified in the 1954 Code. In the 1954 Code the first and second sentences of Section 117(j)(1) of the 1939 Code have been placed in separately numbered paragraphs. The old first sentence is now labelled the "General Rule" and the old "A" and "B" special limitations as to inventories and property held for sale to customers have been placed in separate subparagraphs thereunder. (Section 1231(b)(1)(A) and (B), Internal Revenue Code of 1954.) The special rule as to timber previously contained in the second sentence of Section 117(j)(1) is now placed in a separately numbered paragraph, headed "Timber or coal" (Section 1231(b)(2), Internal Revenue Code of 1954). The special rules giving capital gain treatment to sales of breeding livestock and unharvested crops, which the Congress clearly intended were *not* to be treated as property held for sale to customers in the ordinary course of business, also were placed in separately numbered paragraphs (Section 1231(b)(3) and 1231(b)(4)). Any inferential construction carrying the property held for sale to customers restriction of the "General Rule" into these separately numbered paragraphs would defeat their very purpose.

The Committee Reports make it clear that these changes in the Internal Revenue Code of 1954 were merely editorial in nature and that no change in substance was intended. House Report No. 1337, 83d Cong., 2nd Sess., p. A275, contains the following report on section 1231:

*"Section 1231. Property used in the trade or business and involuntary conversions.*

This section is derived from section 117(j) of present law. *There is no substantive change intended but*

*some rearrangement has been made.*" (Emphasis supplied)

Senate Report No. 1622, 83d Cong., 2d Sess. p. 433, contains the following report on such section:

*"Section 1231. Property used in the trade or business and involuntary conversions.*

This section corresponds to section 1231 of the bill as passed by the House but makes one amendment. It is derived from section 117(j) of present law. Subsection (b)(2) has been amended to apply to iron ore to which section 631(c) applies." [The amendment as to iron ore was deleted by floor amendment before the Bill passed the Senate.]

### Conclusion

We respectfully submit that the Tax Court erred in holding that capital gains treatment is not available under Sections 117(j) and (k)(2) of the 1939 Code, where the timber disposed of was held for sale to customers in the ordinary course of business.

Respectfully submitted,

HENRY BAHR,  
CHARLES W. BRIGGS,  
THOMAS B. STOEL,  
CHARLES A. STRONG,  
LAURENS WILLIAMS,  
*Amici Curiae.*

BRIGGS, GILBERT, MORTON, KYLE and MACARTNEY  
HART, SPENCER, McCULLOUGH, ROCKWOOD and DAVIES  
SUTHERLAND, ASBILL and BRENNAN  
*Of Counsel.*



No. 15442

---

United States  
Court of Appeals  
for the Ninth Circuit

---

NATIONAL LIFE AND ACCIDENT INSUR-  
ANCE COMPANY, Appellant,

vs.

VERDA A. GOREY, Appellee.

---

Transcript of Record

---

Appeal from the United States District Court for the Southern  
District of California, Central Division

FILED

APR 10 1957

PAUL P. O'BRIEN, CLERK





No. 15442

---

---

United States  
Court of Appeals  
for the Ninth Circuit

---

NATIONAL LIFE AND ACCIDENT INSUR-  
ANCE COMPANY, Appellant,

vs.

VERDA A. GOREY, Appellee.

---

Transcript of Record

---

Appeal from the United States District Court for the Southern  
District of California, Central Division

---

---



## INDEX

[Clerk's Note: When deemed likely to be of an important nature, errors or doubtful matters appearing in the original certified record are printed literally in italic; and, likewise, cancelled matter appearing in the original certified record is printed and cancelled herein accordingly. When possible, an omission from the text is indicated by printing in italic the two words between which the omission seems to occur.]

	PAGE
Answer to Complaint .....	5
Appeal:	
Certificate of Clerk to Transcript of Record on .....	31
Notice of .....	29
Statement of Points on (DC) .....	30
Statement of Points on (USCA) .....	140
Certificate of Clerk to Transcript of Record ..	31
Complaint .....	3
Instructions Requested by Defendant (Partial)	17
Judgment .....	23
Motion to Set Aside Verdict and for Judgment or for New Trial and Notice of Motion.....	24
Names and Addresses of Attorneys .....	1
Notice of Appeal .....	29
Order on Motion for Judgment Notwithstanding the Verdict, etc. ....	28

Statement of Admitted Facts and Statement of Unadmitted Facts Not to be Contested (Contained in Pretrial Stipulation)	12
Statement of Points on Appeal (DC)	30
Statement of Points on Appeal (USCA)	140
Transcript of Proceedings and Testimony	33
Answers to Interrogatories by Eldon Stevenson, Jr.	96
Exceptions to Court's Instructions	133
Exhibits for Defendant:	
A—Application for Insurance dated April 14, 1954 (Portions)	43
B—Notice of Claim, Proof of Death and Claimant's Certificate (Portions)	79
E—Report of Dr. Travis Windsor	54
G—Deposition of Jack D. Gwaltney	83
G-1—Deposition of Dr. Lloyd C. Miller	91
Instructions to the Jury	120
Motion for Directed Verdict	105
Witnesses:	
Gorey, Verda A.	
—direct	39
—cross	41
—recalled, redirect	104

## Transcript of Proceedings—(Continued):

## Witnesses—(Continued):

## Kerchner, Dr. R. R., Sr.

—direct .....	46
—cross .....	58
—recalled, redirect .....	67
—recross .....	69

## Smith, Lawson W.

—direct .....	72
—cross .....	76

Verdict .....	22
---------------	----



## NAMES AND ADDRESSES OF ATTORNEYS

For appellant:

JOHN C. MORROW,  
210 No. 7th Street,  
Los Angeles 14, California.

For appellee:

L. E. McMANUS  
8505 Rosemead Blvd.,  
Rivera, California.





In the Superior Court of the State of California  
in and for the County of Los Angeles

No. S.G. C 1069

VERDA A. GOREY, Plaintiff,

vs.

THE NATIONAL LIFE AND ACCIDENT IN-  
SURANCE COMPANY, Defendant.

COMPLAINT ON CONTRACT OF LIFE  
INSURANCE

The plaintiff complains of the defendant and for  
cause of action alleges:

I.

That the defendant is a corporation doing busi-  
ness in the county of Los Angeles and state of Cali-  
fornia.

II.

That plaintiff, Verda A. Gorey, is the wife of  
George E. Gorey, now deceased, and the beneficiary  
named in policy number 2081957 on the life of  
George E. Gorey.

III.

That on or about the first day of May, 1954 at  
Whittier, California in consideration of the pay-  
ment of the premiums of \$8.38 monthly, the defend-  
ant, by its agents duly authorized thereto, executed  
its written policy of insurance number 2081957 to  
one George E. Gorey on his life in the sum of nine  
thousand three hundred sixty three dollars.

IV.

That on the 19th day of November, 1955 at Whittier, California, said George E. Gorey died.

V.

That up to the time of the death of said George E. Gorey, all premiums accrued upon said policy were fully paid.

VI.

That the said George E. Gorey and the plaintiff each performed all the conditions of said insurance on their part, and the plaintiff prior to the commencement of this action gave to the defendant notice and proofs of the death of said George E. Gorey, as aforesaid and demanded payment of the sum of \$9363 whereupon defendant demanded of the plaintiff surrender of the policy of insurance aforementioned to it as a condition of payment; that the plaintiff surrendered the policy of insurance to defendant, and the said policy is now in the possession of defendant.

VII.

That the said sum has not been paid nor any part thereof, and that same is now due thereon from the defendant to plaintiff.

Wherefore, plaintiff prays judgment against the defendant in the sum of \$9363.00 with interest thereon from the 19th day of November, 1955, at the rate of seven per cent per annum, and for the

costs of suit and such other and further relief as to this Court seems just and equitable.

L. E. McMANUS,

Attorney for the Plaintiff

Duly Verified.

[Endorsed]: Filed March 16, 1956.

---

In the United States District Court, Southern  
District of California, Central Division

No. 19691 - WM

VERDA A. GOREY,

Plaintiff,

vs.

THE NATIONAL LIFE AND ACCIDENT IN-  
SURANCE COMPANY, Defendant.

### ANSWER TO COMPLAINT

Defendant The National Life and Accident Insurance Company, answers plaintiff's complaint herein as follows:

#### First Defense

##### I.

Defendant admits the allegations contained in paragraphs I, II, IV and V of plaintiff's complaint.

##### II.

Defendant admits the allegations of paragraph III of plaintiff's complaint, except as follows: Defendant denies that the policy therein mentioned is or was in the sum of \$9363.00 or in any other sum other than the Ultimate Amount Insured of \$3300.00,

plus amount of family income of \$33.00 monthly for such period as is mentioned therein; and defendant alleges that as an additional and material consideration and inducement for the issuance of said policy, said George E. Gorey on or about April 14, 1954, made, executed and delivered to the defendant his written application for issuance and delivery to him by defendant of said policy of insurance; and that a true copy of said application is attached hereto marked Exhibit "A" and made a part hereof and defendant alleges that it relied upon the truth of all of the statements and representations made by said George E. Gorey and contained therein. Defendant further alleges that on or about April 20, 1954, said George E. Gorey stated to Sutton H. Groff, M. D., the defendant's medical examiner, the following: that he had never had any ailment or disease of the heart, that he had never consulted any physician, and that he had never undergone an electrocardiogram. Defendant alleges that it relied upon the truth of all of the statements and representations made by said George E. Gorey to defendant's said medical examiner. Defendant alleges that said policy of insurance was issued by defendant under date of April 30, 1954 and was thereafter delivered to said George E. Gorey; that said application, Exhibit "A" and said policy of insurance provide that said policy would become effective only after delivery thereof to the insured during his lifetime and good health; and that a true copy of said application, Exhibit "A" aforesaid, was attached to and made a part of said policy.

## III.

Defendant, answering paragraph VI of plaintiff's complaint, admits that after the death of said insured and prior to the commencement of her action, plaintiff gave defendant notice and proofs of the death of said George E. Gorey and demanded payment of the sum she claimed to be due under said policy; admits that plaintiff delivered said policy to defendant, but denies that it was delivered for any reason or under any conditions other than as hereinafter alleged. Defendant alleges that after the receipt of the notice and proofs of death of said George E. Gorey from plaintiff, it made an investigation of the facts and circumstances connected with his securing said policy of insurance; that from such investigation, it for the first time learned that he had concealed and misrepresented the true condition of his health as well as concealed the facts that he had or had had an ailment or disease of the heart, that he had consulted a physician therefor, and that he had undergone an electrocardiogram. Defendant alleges that it advised plaintiff of said investigation and of the concealments and misrepresentations so made by said George E. Gorey, and that because of the same, it was not liable for and it would not pay her the death benefit mentioned in said policy, nor any other sum except the amount of the premiums it had received thereunder, plus interest on said premiums from the dates of payment thereof; that defendant advised plaintiff that said premiums and interest amounted to \$168.07 and it would pay plaintiff the same upon surrender and

delivery of the policy and in full settlement of all claims in connection therewith. Defendant alleges that on or about January 10, 1956 it paid said plaintiff said \$168.07 as and in full settlement of plaintiff's claims under and in connection with said policy and plaintiff thereupon surrendered and delivered said policy to *plaintiff*. Except as hereinabove expressly admitted and alleged, defendant denies each and all of the allegations contained in said paragraph VI of plaintiff's complaint.

#### IV.

Denies that there is now due from defendant to plaintiff by reason of said policy, or otherwise, or at all, the sum of \$9363.00 or any other sum or amount whatever.

#### Second Defense

##### I.

Defendant repeats herein paragraphs I, II, III and IV of defendant's first defense hereinabove set forth and makes the same a part hereof as though fully realleged herein.

##### II.

Defendant alleges that in and by said application, Exhibit "A" aforesaid, and the said policy of insurance No. 2081957, said George E. Gorey expressly and fraudulently stated and warranted that at the time of the execution of said application he had never had any ailment or disease and particularly had never had any ailment or disease of the heart, that he had never consulted any physician and that there was nothing in his personal history

not mentioned elsewhere in said application; that each of said statements and warranties was material to the risk to be insured against and they were relied upon by defendant in issuing and delivering said policy to said George E. Gorey; and that in truth and in fact said George E. Gorey then and prior to the execution of said application had an ailment of the heart, that he had consulted with and received treatment from a physician, namely, R. R. Kerchner, M. D., and that he had undergone an electrocardiogram. Defendant alleges that it was wholly without knowledge of the falsity of said statements and breach of said warranties at the inception of said policy of insurance, and that by reason of the falsity of said statements and breach of warranties in its inception, said policy of insurance did not become effective and no obligation arose against the defendant thereunder, or otherwise, or at all, except to pay plaintiff the amount of the premiums theretofore paid thereon, and interest thereon. Alleges that defendant paid plaintiff said premiums and interest, amounting to \$168.07, prior to the filing of plaintiff's action on said policy.

### Third Defense

#### I.

Defendent repeats herein paragraphs I, II, III and IV of defendant's first defense hereinabove set forth and makes the same a part hereof as though fully realleged herein.

#### II.

Defendant alleges that at the time of executing

said application, Exhibit "A" aforesaid, said George E. Gorey stated therein that he had no ailment or disease and particularly no ailment or disease of the heart and that he had never consulted any physician and that there was nothing in his personal history not mentioned elsewhere in said application; that said George E. Gorey on or about April 20, 1954, stated to Sutton H. Groff, M. D., defendant's medical examiner that he had never had any ailment or disease of the heart, that he had never consulted any physician and that he had never undergone any electrocardiogram; that defendant relied upon said statements and representations; that in truth and in fact at the time of executing said application, and at the time of making said statements to defendant's said medical examiner, said George E. Gorey did have an ailment or disease of the heart, he had previously consulted and been treated therefor by a physician, namely, R. R. Kerchner, M. D. during the month of October, 1953, and that during said month of October, 1953 he had undergone an electrocardiogram by said physician, R. R. Kerchner, M. D. Defendant alleges that at the time of the issue of said policy of insurance and at the time of the payment of the first premium thereon and at the time of the delivery to and acceptance of said policy by said George E. Gorey, he was not in good health; that the falsity of the aforesaid statements and representations so made by him was at all times well known to said George E. Gorey, but he failed then or at all to disclose the falsity of the same, or any thereof, to the



defendant; and that the falsity of said statements and representations were not known to or discovered by the defendant until some time after the death on November 19, 1955 of said George E. Gorey. Defendant alleges that by reason of the false statements and representations of said George E. Gorey aforesaid, the defendant was deceived and induced to issue and deliver the said policy of insurance, and that no obligation arose thereunder or otherwise or at all, except to pay plaintiff the amount of the premiums theretofore paid thereon, and interest thereon; and defendant alleges that it paid plaintiff therefor in the sum of \$168.07 prior to the filing of plaintiff's action on said policy.

Fourth Defense

I.

The Complaint fails to state a claim against the defendant upon which relief can be granted.

Wherefore defendant prays judgment as follows:

1. That plaintiff take nothing by her action;
2. For costs of suit; and
3. For such other relief as may be proper.

Dated March 21, 1956.

OVILA N. NORMANDIN,  
JOHN C. MORROW,

/s/ By OVILA N. NORMANDIN,

Attorneys for defendant The National Life and  
Accident Insurance Company.

Duly Verified.

Affidavit of Service by Mail attached.

[Endorsed]: Filed March 23, 1956.

[Title of District Court and Cause.]

PRE-TRIAL STIPULATIONS

(A) "Statement of Admitted Facts"

\* \* \* \* \*

Counsel for the respective parties in the above entitled proceeding, pursuant to the Court order of April 15, 1956 re Pre-trial proceedings, have conferred with reference to the matters in litigation as to which admissions may be made; and they have agreed to and hereby make the following "Statement of Admitted Facts"

1. That the plaintiff is and at all times mentioned in the complaint was a resident and citizen of the State of California, and is the surviving wife of George E. Gorey, now deceased.

2. That the defendant is a corporation organized and existing under the laws of the State of Tennessee, and a resident and citizen of the State of Tennessee; and that it was and is doing business in the County of Los Angeles, State of California.

3. That on or about April 14, 1954 said George E. Gorey made, executed and delivered to defendant at Whittier, California, his written application for the issuance and delivery to him of a life insurance policy on his life in the amount of \$3300.00 upon the Family Income Plan. That a true copy of said application marked Exhibit "A" is attached to and made a part of defendant's Answer on file herein.

4. That said George E. Gorey paid defendant the sum of \$8.34 on or about April 14, 1954 as the first monthly premium on said policy.

5. That defendant relied upon the application, the report of the medical examiner of defendant and the report of inspection by defendant's Agent and under date of April 30, 1954 it issued and thereafter delivered to George E. Gorey its life insurance policy No. 2081957 on his life; and that plaintiff was and is named as beneficiary in said policy. That said life insurance policy provides that in the event of the death of said George E. Gorey during the second year of the policy, the beneficiary would have the right to elect to receive payment of the sum of \$8824.00 as the commuted proceeds payable under said policy in lieu of all other settlement provisions thereunder, in full settlement of all claims and rights of the beneficiary.

6. That said application, Exhibit "A", and said policy of insurance provide that the policy would become effective only after delivery thereof to the insured during his lifetime and good health; and that a true copy of said application, Exhibit "A" aforesaid, was attached to and made a part of said policy at the time of issuance and delivery thereof to said George E. Gorey.

7. That said George E. Gorey died on November 19, 1955 at Whittier, California, and up to that time all premiums called for by said policy had been fully paid.

8. That after the death of said George E. Gorey and before the commencement of plaintiff's action herein, plaintiff gave defendant notice and proofs of death of said George E. Gorey and demanded

payment of the sum she claimed to be due under said policy.

9. That after said receipt by defendant of the notice and proofs of death of said George E. Gorey, and before plaintiff filed her action herein, the defendant made an investigation of the facts and circumstances connected with his applying for and securing said policy of insurance; that it advised the plaintiff of said investigation and the defendant told plaintiff it was not liable for and it would not pay her the death benefit mentioned in the policy, nor any other sum, except the amount of premiums it had received thereunder, plus interest on the same from the dates of payments thereof; that defendant advised plaintiff said premiums and interest amounted to \$168.07.

10. That said application, Exhibit "A" aforesaid, stated among other things, the following questions to be answered by the applicant and contains the following answers to said questions, to-wit: "Question 54. Have you ever had any ailment or disease of: B. Heart or lungs? Yes or No. No." "Question 60. State names and addresses of physicians you have ever consulted and give the occasion by reference to question number and letters above. None". That defendant relied upon said application and on said answers to said questions in issuing and delivering said policy to said George E. Gorey.

11. That on April 20, 1954 said George E. Gorey was examined by Sutton H. Groff, M. D., the de-

defendant's medical examiner at Montebello, California, in connection with said application, Exhibit "A" aforesaid; that said medical examiner's written report of said examination was set forth on the reverse side of said application, Exhibit "A" aforesaid, and was delivered to the defendant before said policy was issued; that said medical examiner's report was exhibited to plaintiff's counsel on May 11, 1956; and that defendant relied upon said medical examiner's report in issuing and delivering said policy to said George E. Gorey.

Dated May 25, 1956.

/s/ L. E. McMANUS,  
Attorney for Plaintiff.

OVILA N. NORMANDIN,  
JOHN C. MORROW,

/s/ By OVILA N. NORMANDIN,  
Attorneys for Defendant.

(B) "Statement of Unadmitted Facts—Not To Be Contested."

Counsel for the respective parties in the above entitled proceeding, pursuant to the Court order of April 15, 1956 re Pre-trial proceedings, have conferred with reference to the matters in litigation as to Unadmitted Facts which are not to be contested; and they have agreed to and hereby make the following "Statement of Unadmitted Facts, Not to be Contested".

1. That during the month of October, 1953, at Montebello, California, George E. Gorey consulted

and was examined by R. R. Kerchner, M. D.; that said R. R. Kerchner, M. D. diagnosed the physical condition of said George E. Gorey and had him undergo an electrocardiogram; and that following his electrocardiogram, said R. R. Kerchner, M. D. prescribed treatment for George E. Gorey.

2. That after the death of George E. Gorey and after the defendant completed its investigation of the facts and circumstances connected with his application for and securing the issuance to him of the life insurance policy in suit from the defendant, said defendant tendered and delivered to plaintiff its check No. 42127 in her favor for \$168.07 representing the premiums theretofore paid on said policy, plus interest.

3. That the disease or condition directly leading to death as shown in the certified copy of the Certificate of Death of said George E. Gorey was Acute Myocardial Infarction, and the antecedent cause was Coronary-Arterio-sclerosis.

Dated May 31, 1956.

OVILA N. NORMANDIN,  
JOHN C. MORROW,

/s/ By OVILA N. NORMANDIN,  
Attorneys for Defendant.

/s/ L. E. McMANUS  
Attorney for Plaintiff.

\* \* \* \* \*

[Endorsed]: Filed June 1, 1956.

[Title of District Court and Cause.]

DEFENDANT THE NATIONAL LIFE AND ACCIDENT INSURANCE COMPANY'S REQUESTED JURY INSTRUCTIONS.

Defendant The National Life and Accident Insurance Company hereby requests that each and all of the following instructions be given by the Court to the jury.

OVILA N. NORMANDIN and JOHN C. MORROW,

/s/ By JOHN C. MORROW,

Attorneys for Defendant The National Life and Accident Insurance Company.

\* \* \* \* \*

Defendant's Requested Instruction No. 3

You are instructed that if George E. Gorey was treated by a physician before the date of the making of the application for the policy of insurance involved in this case, that is, before April 14, 1954, that fact is presumed to have been within the personal knowledge of George E. Gorey, and if his representations in his application with regard to having ever consulted a physician for any ailment or disease of the heart are false, he was guilty of fraud, although as a matter of fact, he might not have intended to deceive the company, and your verdict should be for the defendant company.

Telford v. New York Life Insurance Co., 9 Cal. (2d) 103.

\* \* \* \* \*

Defendant's Requested Instruction No. 5

You are instructed that if George E. Gorey, the applicant, concealed the fact that he had consulted a physician concerning which enquiry was made by the defendant company in the application for insurance, it is not necessary that the matter concealed affect the length of the insured's life. If you find that there was a concealment by reason of the failure of George E. Gorey to disclose his consultations with a physician or physicians, your verdict must be for the defendant company even though you believe that the ailment or disease for which the consultation or consultations was had did not shorten the life of George E. Gorey.

McEwen v. New York Life Insurance Co.,  
42 Cal. App. 133.

\* \* \* \* \*

Defendant's Requested Instruction No. 8

If George E. Gorey concealed any material fact or facts with regard to his medical history, the plaintiff cannot recover in this action and this is true, although you may find that the facts concealed had no connection with the cause of George E. Gorey's death.

Madsen v. Maryland, 168 Cal. 204.

McEwen v. New York Life Insurance Co.,  
42 Cal. App. 133.



## Defendant's Requested Instruction No. 9

You are instructed that the requirement of fair dealing is laid on both parties to the insurance policy involved in this action. This requirement imposed a duty on the part of George E. Gorey, the insured, to read the insurance policy and the photostatic copy of his application attached thereto upon the delivery thereof to him by the defendant company, and you may assume that he did so and that he had full knowledge of the questions contained in said application and his answers thereto. He also had a duty to report to the defendant company any misrepresentations set forth in or omissions in his application within a reasonable time. If you find that he neglected to so inform the defendant company of any such material misrepresentation or omission, your verdict should be for the defendant company.

Telford v. New York Life Insurance Co., 9  
Cal. (2d) 103.

Layton v. New York Life Insurance Co., 55  
Cal. App. 202.

## Defendant's Requested Instruction No. 10

You are instructed that the fact that George E. Gorey was examined by one of the defendant company's medical examiners at or about the time of his application for insurance in no way affects the right of the defendant company to deny liability under the policy of insurance involved in this action if a full and truthful disclosure of facts concern-

ing which the defendant company made enquiry was not made by George E. Gorey in his application for insurance.

California Insurance Code, Sections 331 and 359.

Robinson v. Occidental Life Insurance Co., 131 Cal. App. (2d) 581.

Defendant's Requested Instruction No. 11

You are instructed that the policy of insurance involved in this action was delivered to George E. Gorey in May, 1954, and at the time of delivery a photostatic copy of the application therefor was attached thereto; that the policy and the application therefor constituted the entire contract between the defendant company and George E. Gorey. George E. Gorey, over his own signature, declared that each of the statements contained in said application were full, complete, true and without exception, unless such exception was noted. The statements contained in the application thereby became his solemn representations and of the same binding force upon him as though he had himself written them out in his own handwriting and signed them.

Layton v. New York Life Insurance Co., 55 Cal. App. 202.

Westphall v. Metropolitan Life Insurance Co., 27 Cal. App. 734.

Robinson v. Occidental Life Insurance Co., 131 Cal. App. (2d) 581.

Defendant's Requested Instruction No. 12

You are instructed that if you find that George E. Gorey, in October, 1953, supposing himself to be in need of a physician, did consult a physician and answered such enquiries as the physician deemed pertinent and received aid, advice or treatment which the physician deemed necessary, he had consulted a physician within the meaning of the question asked relative thereto in his application for the insurance policy.

California Western States Life Insurance Co.  
v. Feinstein, 15 Cal. (2d) 413.

Whitney v. West Coast Life Insurance Co., 177  
Cal. 74.

Defendant's Requested Instruction No. 13

The defendant company was entitled to have a full, complete and true statement by George E. Gorey of the names and addresses of physicians he had ever consulted before he applied for the policy of insurance involved in this action insofar as the defendant company made enquiries of George E. Gorey relative thereto at the time he made said application. The written application for the insurance policy involved in this action made by George E. Gorey to the defendant company on or about April 14, 1954 includes the question to George E. Gorey, the applicant, : "State names and addresses of physicians you have ever consulted and give the occasion by reference to question numbers and let-

ters above". If you find that George E. Gorey answered this question in said application by stating that he had never consulted any physicians, and if you further find that before making said application George E. Gorey had consulted a physician, namely, R. R. Kerchner, M.D., your verdict must be for the defendant company.

Whitney v. West Coast Life Insurance Co.,  
177 Cal. 74.

\* \* \* \* \*

Affidavit of Service by Mail Attached.

[Endorsed]: Filed June 6, 1956.

---

[Title of District Court and Cause.]

### VERDICT

We, the jury in the above entitled cause, find in favor of the plaintiff, Verda A. Gorey, and against the defendant, The National Life and Accident Insurance Company, for the sum of \$9,431.00.

Los Angeles, California, November 15, 1956.

/s/ JOHN J. RUDEEN,  
Foreman of the Jury.

[Endorsed]: Filed Nov. 15, 1956.

In The United States District Court, Southern  
District of California, Central Division

No. 19691-WM

VERDA A. GOREY,

Plaintiff,

vs.

THE NATIONAL LIFE AND ACCIDENT IN-  
SURANCE CO., Defendant.

### JUDGMENT

This cause having been tried and submitted to the jury and the Jury having returned its verdict, now therefore, in accordance with said verdict and pursuant to law and the premises aforesaid,

It Is Ordered, Adjudged and Decreed that the Plaintiff, Verda A. Gorey, have and recover of and from the Defendant, The National Life and Accident Insurance Company, the sum of Nine Thousand Four Hundred and Thirty-one Dollars (\$9,431.00), together with costs taxed in the amount of \$57.85.

Witness the Honorable William C. Mathes, Judge of the above-entitled court, this 16th day of November, 1956.

JOHN A. CHILDRESS,

Clerk,

/s/ By P. D. HOOSER,

Deputy Clerk.

[Endorsed]: Filed Nov. 16, 1956. Docketed and Entered Nov. 20, 1956.

[Title of District Court and Cause.]

MOTION TO SET ASIDE VERDICT AND FOR  
JUDGMENT OR FOR NEW TRIAL—NO-  
TICE OF MOTION

Defendant The National Life and Accident Insurance Company hereby moves the Court to set aside the verdict received and entered in the above entitled cause on November 15, 1956, and to enter judgment for defendant in accordance with its motion for a directed verdict on the following grounds:

The motion for a directed verdict should have been granted because:

1. The evidence in the case showed conclusively, and was without conflict, that the insured in his written application for the insurance policy falsely represented to defendant:

(a) That he had never had any ailment or disease of the heart, and

(b) That he never had consulted any physician.

2. The evidence in the case showed conclusively, and was without conflict, that the insured by his answers to questions in his written application for the insurance policy and at all times thereafter concealed from defendant:

(a) That he had consulted a physician, viz, Dr. R. R. Kerehner in October, 1953, and thereafter prior to the date of the application, and

(b) That he had a disease of the heart, viz, coronary arteriosclerosis and coronary insufficiency.

3. The evidence in this case showed conclusively, and was without conflict, that by the report of defendant's medical examiner signed by the insured prior to the issuance of the insurance policy the insured misrepresented to said medical examiner that he had never undergone an electrocardiogram and also that the insured concealed from said medical examiner the fact that he had undergone an electrocardiogram.

4. It was an admitted fact in the case that defendant relied upon said application and said medical examiner's report in issuing said insurance policy.

5. The evidence in the case showed conclusively and was without conflict, that the insured did not at any time after the insurance policy was issued and delivered to him communicate with defendant or advise defendant of any such or any misrepresentation or misstatement set forth in said application, a photostatic copy of which was attached to the policy, nor did insured advise defendant that he had previously undergone an electrocardiogram.

6. The evidence in the case showed conclusively and was without conflict, that defendant would not have issued the policy if it had been advised of or had had knowledge of any of said facts misrepresented to and concealed from it by insured, and the evidence showed conclusively, and was without conflict, that defendant had no knowledge of any of

said misrepresentations or concealments at any time until after the insured died.

In the alternative, defendant moves the Court to set aside the verdict and grant defendant a new trial on each of the following grounds, vis:

1. That the verdict is against the weight of the evidence and contrary to the preponderance of the evidence on each and all of the matters hereinabove specified under points (1) to (6), inclusive; that accordingly defendant made a legal defense to plaintiff's action on the policy, and that the verdict will result in a miscarriage of justice if not set aside.

2. That substantial and prejudicial error of law was committed and resulted from the giving of instructions to the jury on the law, to wit, instructions numbers 6-A, 12, 12-A, 13 and 14.

3. That substantial and prejudicial error of law was committed and resulted from the failure of the Court to give instructions to the jury on the law as to various important questions necessarily involved in defendant's affirmative defenses and upon which evidence was introduced, vis, defendant's requested instructions numbers 3, 5, 7, 8, 9, 10, 11 and 12.

These motion are made upon all of the pleadings, files and proceedings in this case.

Dated: November 21, 1956.

OVILA N. NORMANDIN and  
JOHN C. MORROW

/s/ By JOHN C. MORROW,

Attorneys for defendant, The National Life and  
Accident Insurance Company.



NOTICE OF MOTION

To Plaintiff, Verda A. Gorey, and to L. E. McManus, Esq., her attorney:

Please Take Notice that the undersigned will bring the above motions on for hearing before this court in the courtroom of the Honorable William C. Mathes, District Judge, in the Federal Court House and Post Office Building, Los Angeles, California, on Monday, December 3, 1956, at the hour of 10:00 o'clock A. M., of said day, or as soon thereafter as counsel can be heard.

Said motions are made upon the grounds stated in the attached written motions, upon all of the pleadings, files and proceedings in this case, and upon the attached memorandum of points and authorities.

Dated: November 21, 1956.

OVILA N. NORMANDIN and  
JOHN C. MORROW,

/s/ By JOHN C. MORROW,

Attorneys for defendant, The National Life and  
Accident Insurance Company.

\* \* \* \* \*

Affidavit of Service by Mail Attached.

[Endorsed]: Filed Nov. 21, 1956.

[Title of District Court and Cause.]

ORDER ON DEFENDANT'S MOTIONS FOR  
JUDGMENT n.o.v. (Fed. R. Civ. P. 50 (b))  
or FOR A NEW TRIAL

This cause having come before the Court for hearing on the motions of defendant filed November 21, 1956, for judgment notwithstanding the verdict or for a new trial (Fed. R. Civ. P. 5 (b)), and the motions having been heard and submitted for decision,

It Is Ordered that defendant's motions are hereby denied. (See: *Columbia Ins. Co. v. Lawrence*, 35 U. S. (10 Peters) 507, 516 (1836); *Liberty National Life Ins. Co. vs. Hamilton*, 237 Fed. 2nd 235 (6th Cir. 1956); *Gates v. General Cas. Co.*, 120 Fed. 2nd 925 (9th Cir. 1941); *Ocean Acc. etc. Corp. v. Rubin*, 73 Fed. 2nd 157 (9th Cir. 1934); *Parrish v. Acacia Mut. Life Ins. Co.*, 92 Fed. Supp. 300 (S.D. Cal. 1949), affirmed 184 F. 2nd 185 (9th Cir. 1950); *Ransom v. Penn. Mut. Life Ins. Co.*, 274 P. 2nd (Cal) 633, 637 (1954); *Robinson v. Occidental Life Ins. Co.*, 281 P. 2nd (Cal. App.) 39, 42 (1955); *Standard Accident Ins. Co. v. Pratt*, 278 P. 2nd (Cal. App.) 489, 492 (1955)).

December 21, 1956.

/s/ WM. C. MATHES,  
United States District Judge.

L. E. McManus,  
Attorney for Plaintiff.

Ovila N. Normandin and  
John C. Morrow,  
Attorneys for Defendant.

[Endorsed]: Filed Dec. 21, 1956.

---

[Title of District Court and Cause.]

### NOTICE OF APPEAL

Notice Is Hereby Given that defendant The National Life and Accident Insurance Company hereby appeals to the United States Court of Appeals For The Ninth Circuit from the final judgment entered in this action on November 20, 1956, and from the order entered in this action on December 21, 1956, denying said defendant's motion to set aside verdict and for judgment or for new trial under F.R.C.P., Rules 50 (b) and 59.

Dated: January 8, 1957.

OVILA N. NORMANDIN and  
JOHN C. MORROW,

/s/ By JOHN C. MORROW,

Attorneys for the defendant The National Life and  
Accident Insurance Company.

[Endorsed]: Filed Jan. 8, 1957.

[Title of District Court and Cause.]

STATEMENT OF POINTS ON WHICH DEFENDANT INTENDS TO RELY ON APPEAL

The points upon which defendant and appellant, The National Life and Accident Insurance Company intends to rely on this appeal are as follows:

1. The court erred in denying and in not granting defendant's motion for a directed verdict and motion to set aside verdict and for judgment under F.R.C.P. Rule 50(b).

2. The court erred in instructing the jury and in refusing to give certain jury instructions requested by defendant.

3. The court erred in denying and in not granting defendant's alternative motion for a new trial.

Dated: February 6th, 1957.

OVILA N. NORMANDIN and  
JOHN C. MORROW,

/s/ By JOHN C. MORROW,

Attorneys for defendant and appellant The National Life and Accident Insurance Company.

Affidavit of Service by Mail Attached.

[Endorsed]: Filed Feb. 7, 1957.

[Title of District Court and Cause.]

CERTIFICATE BY CLERK

I, John A. Childress, Clerk of the above-entitled Court, hereby certify that the items listed below constitute the transcript of record on appeal to the United States Court of Appeals for the Ninth Circuit, in the above-entitled cause:

The foregoing pages numbered 1 to 150, inclusive, containing the original

Petition for Removal; Notice of Filing Petition for Removal;

Answer;

Demand for Jury Trial;

Order for Pre-Trial Proceedings;

Plaintiff's Memorandum Prior to Trial;

Interrogatories to Plaintiff;

Memorandum of Law on behalf of Defendant;

Pre-Trial Stipulations;

Requested Instructions by the Plaintiff;

Defendant's Pre-Trial Opening Statement & Pre-Trial Statement as to Status;

Defendant's Requested Jury Instructions;

Answer to Defendant's Interrogatories;

Interrogatories to President of Defendant;

Pre-Trial Statement as to Status of Case;

Answer of President of Defendant to Plaintiff's Interrogatories;

Defendant's Additional Requested Jury Instruction;

Defendant's Request for Special Verdict and Requested Forms of Written Questions;

Plaintiff's Objections to Special Verdict & Request for Interrogatories;

Defendant's Reply to Objections to Special Verdict & Defendant's Objections to Requested Interrogatories;

Verdict;

Judgment;

Motion to Set Aside Verdict & for Judgment or for New Trial, together with Notice of and Memorandum of Points & Authorities in Support Thereof;

Bill of Costs;

Memorandum of Points & Authorities in Opposition to Defendant's Motion to Set Aside the Verdict and for Judgment and in the Alternative for new Trial;

Order on Defendant's Motion for Judgment;

Notice of Appeal;

Statement of Points on Which Appellant Intends to Rely;

Designation of Record; and a full, true and correct copy of the Minutes of the Court on November 13, 14, 15, 1956; December 3, 1956;

B. Plaintiff's exhibits 1, 2 & 3 and defendant's A through G-1, inclusive.

I further certify that my fee for preparing the

foregoing record amounting to \$1.60, has been paid by appellant.

Witness my hand and the seal of said District Court, this 15th day of February, 1957.

[Seal]                      JOHN A. CHILDRESS,  
   Clerk.

/s/ By CHARLES E. JONES,  
   Deputy.

In The United States District Court, Southern  
District of California, Central Division

No. 19691-WM Civil

VERDA A. GOREY,    Plaintiff,

vs.

THE NATIONAL LIFE AND ACCIDENT IN-  
SURANCE CO.,    Defendant.

REPORTER'S TRANSCRIPT OF  
PROCEEDINGS

Los Angeles, Calif., Nov. 13 and 14, 1956

Honorable William C. Mathes, Judge Presiding.

Appearances: For the Plaintiff L. E. McManus,  
Esq., 8505 Rosemead, Rivera, California. For the  
Defendant: Ovila N. Normandin and John C. Mor-  
row, Esqs., 740 South Broadway, Los Angeles 14,  
California. [1\*]

\* \* \* \* \*

\* Page numbers appearing at top of page of original Reporter's  
Transcript of Record.

The Court: The plaintiff may call her first witness.

Mr. McManus: Your Honor, I believe that counsel for the defendant and myself can arrive at some stipulations.

The Court: Very well, Mr. McManus, will you stand at the lecturn and present them.

Mr. McManus: This is a statement of admitted facts. One, that the plaintiff is and at all times mentioned in the complaint was a resident and citizen of the State of California and is the surviving wife of George E. Gorey, now deceased. Two, that the defendant is a corporation organized and existing under the laws of the State of Tennessee and a resident and citizen of the State of Tennessee and that it was and is doing business in the County of Los Angeles, State of California. Three, that on or about April 14, 1954, said George E. Gorey made and executed and delivered to the defendant in Whittier, California, his written application [8] for the issuance to and delivery to him of a life insurance policy on his life in the amount of \$3,300 upon the family income plan; that a true copy of said application marked Exhibit A is attached to and made part of the defendant's answer on file herein. Four, that said George E. Gorey paid defendant the sum of \$8.34 on or about April 14, 1954, as the first monthly premium on said policy. Five, that the defendant relied upon the application, the report of the medical examiner of the defendant and the report of inspection by the defendant's agent and under date of April 30, 1954, it issued and thereafter



delivered to George E. Gorey its life insurance policy number 2081957 on his life and that plaintiff was and is named as beneficiary in said policy. That said life insurance policy provides that in the event of the death of said George E. Gorey during the second year of the policy the beneficiary would have the right to elect to receive payment of the sum of \$8,824 as commuted proceeds payable under said policy in lieu of all other settlement provisions thereunder in full settlement of all claims and rights of the beneficiary. Six, that said application, Exhibit A, and said policy of insurance provides that the policy would become effective only if delivered thereafter to the insured during his life in good health and that a true copy of said application, Exhibit A aforesaid, was attached to and made part of said policy at the [9] time of issuance and delivery thereof to said George E. Gorey. Seven, that said George E. Gorey died on November 19, 1955, at Whittier, California, and up to that time all premiums called for by said policy had been fully paid. Eight, that after the death of said George E. Gorey and before the commencement of plaintiff's action herein, plaintiff gave defendant notice and proofs of death of said George E. Gorey and demanded payment of the sum she claimed to be due under said policy. Nine, that after said receipt by defendant of the notice and proofs of death of said George E. Gorey and before plaintiff filed her action herein, the defendant made an investigation of the facts and circumstances connected with his applying for and securing said policy of insurance and that it

advised the plaintiff of said investigation of the defendant and told the plaintiff it was not liable for and it would not pay her the death benefit mentioned in the policy nor any other sum except the sum of premiums it had received thereunder plus interest on the same from the dates of payment. Thereafter that defendant advised plaintiff said premiums and interest amounted to \$168.07. Ten, that said application, Exhibit A aforesaid, stated among other things the following questions to be answered by the applicant and contains the following answers to said questions, to wit, Question 54, "Have you ever had any ailment or disease, (b) Heart or lungs, yes or no?" "No." That means that answer is "No" counsel. [10]

Mr. Morrow: That means that's the answer that's given to the question?

Mr. McManus: Yes. Question 60, "State names and addresses of physicians you have ever consulted and give the occasion by reference to question number and letters above." "None."

Mr. Morrow: The answer is "No," counsel?

Mr. McManus: Yes. That the defendant relied upon said application and on said answers to said questions in issuing and delivering said policy to said George E. Gorey. Eleven, that on April 20, 1954, said George E. Gorey was examined by Sutton H. Groff, M.D., defendant's medical examiner, at Montebello, California in connection with said application, Exhibit A aforesaid. That said medical examiner's written report of said examination was

set forth on the reverse side of said application, Exhibit A aforesaid, and was delivered to the defendant before said policy was issued. That said medical examiner's report was exhibited to plaintiff's counsel on May 11, 1956, and that the defendant relied upon said medical examiner's report in issuing and delivering said policy to said George E. Gorey.

Mr. Morrow: Pardon me just a moment. The stipulation is correct, Mr. McManus. May I inquire privately of Mr. McManus, your Honor?

The Court: You may.

Mr. McManus: And it is further stipulated that the [11] defendant tendered and delivered to plaintiff its check number 42127 in the plaintiff's favor for \$168.07 representing the premiums theretofore paid on said policy plus interest.

Mr. Morrow: So stipulated.

The Court: I assume we include in that stipulation that the plaintiff refused to accept that check?

Mr. Morrow: We were just discussing that matter. We don't know quite how to put it. Anyway, that's the understanding. She didn't accept the check in payment of the death benefit provided in the policy.

Mr. McManus: That's correct, your Honor.

The Court: Very well, the jury will understand that. Here is one of those things I was telling you about, a stipulation where both sides agree certain facts are true, the facts read to you by Mr. McManus is his statement just made and the statements made by Mr. Morrow constitute a stipulation

or agreement that the facts covered by the so-called stipulation are true and you are to accept them without the necessity of calling witnesses and offering evidence to prove that those facts are true. It's time for the noon recess. We will take a recess at this time until 2 o'clock. Before we separate, I must admonish you of your duties not to converse or otherwise communicate among yourselves or anyone else upon any subject touching upon the merits of this trial and not to form or express an opinion on the case to anyone until [12] after the case is finally submitted to you for your verdict. You are now excused until 2 o'clock this afternoon.

(Whereupon the jury retired from the courtroom.)

The Court: Is it stipulated the jury have retired from the courtroom?

Mr. McManus: Yes, your Honor.

The Court: Anything counsel have to take up before we call a recess?

Mr. McManus: I believe I have nothing, your Honor.

Mr. Morrow: We wouldn't know of anything, your Honor. We are going to have witnesses here we spoke about in Chambers at 2 o'clock, which I assume will be plenty of time.

The Court: Oh, yes. You expect to call Mrs. Gorey?

Mr. McManus: I believe there will be——

The Court: To offer the policy?

Mr. McManus: To offer the policy. We will take a short time.

The Court: Very well. We will recess until 2 o'clock, then, gentlemen.

(Whereupon a recess was taken until 2:00 p.m. of the same day.) [13]

The Court: In the case on trial, are you ready to proceed, gentlemen:

Mr. Mc Manus: Yes, your Honor.

The Court: Will you summon the jury, Mr. Bailiff.

(Whereupon the jury enter the jurybox.)

The Court: Is it stipulated, gentlemen, the jury is present?

Mr. McManus: Yes, so stipulated.

The Court: You may proceed.

#### VERDA A. GOREY

called as a witness in her own behalf, having first duly sworn, was examined and testified as follows:

The Clerk: Will you state your name.

The Witness: Mrs. Verda A. Gorey.

Mr. McManus: Will you please mark this for identification.

(The document referred to was marked Plaintiff's Exhibit No. 1 for identification.)

#### Direct Examination

Q. (By Mr. McManus): Mrs. Gorey, you are the widow of George E. Gorey, is that correct?

A. Yes. [14]

Q. Mrs. Gorey, I want to hand you what the reporter has marked as Plaintiff's Exhibit 1 and

(Testimony of Verda A. Gorey.)

ask you if that's the policy which you received from the defendant company?      A. Yes.

The Court: What is your answer?

The Witness: Yes.

Q. (By Mr. McManus): Now, Mrs. Gorey on what date did your husband die?

A. November 19, 1955.

Q. And did you thereafter make claim for payment on this insurance policy?      A. Yes, I did.

Q. And is it a fact that the defendant refused to pay you?      A. Yes.

Mr. McManus: I believe that will be all. You may cross examine. Oh, one other thing. I would like to introduce the death certificate.

Mr. Morrow: I believe you have introduced the policy?

The Court: You offered the policy?

Mr. McManus: Yes.

The Court: Any objection?

Mr. Morrow: No.

The Court: The policy is received as Plaintiff's Exhibit 1. [15]

(The document referred to, marked Plaintiff's Exhibit No. 1, was received in evidence.)

Mr. McManus: Yes, your Honor, Exhibit 1 in evidence. Then the death certificate, defendant's Exhibit No. D.

The Court: Is that a certified copy of the death certificate?

Mr. McManus: Yes, it is.

(Testimony of Verda A. Gorey.)

The Court: Any objection?

Mr. Morrow: No objection, your Honor.

The Court: You offer it?

Mr. McManus: We offer that in evidence.

The Court: Received in evidence as Plaintiff's Exhibit 2.

(The document referred to, marked Defendant's Exhibit D, was received in evidence as Plaintiff's Exhibit 2.)

The Court: Is there any cross examination?

Mr. Morrow: Just one or two questions, your Honor.

#### Cross Examination

Q. (By Mr. Morrow): Mrs. Gorey, the application for insurance attached to the life insurance policy just introduced into evidence states that Mr. Gorey was self-employed and that he was a builder and developer. That's true, was it?

A. Yes. [16]

Q. And how long before his death had he been self-employed as a builder and developer?

A. Well, when he was self-employed, it was several years prior to his death.

Q. By several years you mean more than three or four years?      A. At least two.

Q. Prior to his death?      A. Yes.

Q. The date of the application is, I believe, April 14, 1954. Does that refresh your recollection that he had been self-employed as a builder and developer for some time prior to that date?

(Testimony of Verda A. Gorey.)

A. Well, partially.

Q. How is that?

A. Partially he was self-employed afterwards doing odd jobs.

Q. And for how long before April 14, 1954, had he been self-employed as a builder and developer, approximately how long?

A. It's hard to say exactly but I would say around a year.

Mr. Morrow. Thank you.

The Court: Any further questions of the plaintiff?

Mr. Morrow: No further questions.

Mr. McManus: No further questions. [17]

The Court: You may step down.

Mr. McManus: The plaintiff will rest.

The Court: The plaintiff rests. The defense may proceed.

Mr. Morrow: If the Court please, we have a few exhibits we would like to offer at this time.

The Court: Very well.

Mr. Morrow: The first is the original application for insurance dated April 14, 1954. I might say a photostatic copy is attached to the original life insurance policy but we should like to offer the original application at this time.

The Court: Any objections?

Mr. McManus: No objection.

The Court: It is stipulated to be genuine and in all respects what it purports to be?



Mr. Morrow: Yes, your Honor.

The Court: Received in evidence as Defendant's Exhibit.

The Clerk: Defendant's Exhibit A, your Honor.

(The document referred to was marked Defendant's Exhibit A in evidence.)

Mr. Morrow: The defendant also offers in evidence at this time the medical examiner's report which I believe the clerk has in his possession marked for identification.

The Court: Is it marked, Mr. Clerk?

The Clerk: Yes, your Honor. It has been [18] marked A1 for identification.

Mr. Morrow: As a matter of fact, your Honor, it appears that the document appears in the part of the application or at least it's on the back of the application but it is a separate document.

The Court: This is a printed form. On one side is the application for the insurance and the other side the doctor's medical report.

Mr. Morrow: Yes, your Honor.

The Court: Is it stipulated to be genuine as to what it purports to be?

Mr. McManus: Yes, your Honor.

The Court: Received in evidence as Defendant's Exhibit A1.

(The document referred to, marked Defendant's Exhibit No. A1, was received in evidence.)

Mr. Morrow: I wish to read briefly——

The Court: You may proceed.

Mr. Morrow: Yes, your Honor. I wish to read

briefly from Defendant's Exhibit A which is the application which has just been admitted in evidence, application for insurance dated April 14, 1954, and purporting to be signed by George E. Gorey, as applicant. There are a number of questions and answers on this application. I will read two or three at [19] this question. Question 54 "Have you ever had any ailment or disease of (a) Brain or nerve system." The form is answered "Yes or no." The answer is "No." 54 (b) "Have you ever had any ailment or disease of heart or lungs." The question is "Yes or no." The answer is "No." Question 54—strike 54. Question 60. "State names and addresses of physicians you have ever consulted and give the information by reference to question numbers and letters above." Answer "None." Part 6 of the application reads as follows above the signature of George E. Gorey. "On my own behalf and in behalf of any person who may have or claim any interest in any policy issued hereon, (1) I hereby declare that each of the statements contained herein is full, complete and true without exception unless such exception is noted; (2) I hereby agree that except as provided in the receipt referred to in item 63, the proposed contract shall not be effective until the policy has been issued, the first premium actually paid and accepted by the company and the policy delivered to and accepted by me during the lifetime and good health of the person or persons upon whose death a policy benefit mature; (3) I hereby agree that no statement has been made or information given in

connection with this application which is in any way inconsistent with anything appearing herein or in the above mentioned receipt; (4) I hereby agree that only the president, the vice-president, the secretary or an assistant [20] secretary of the company in writing has the power to waive, alter or modify this application or any policy issued pursuant thereto; (5) to the extent permitted by law I expressly waive on behalf of myself or any other person all provisions of law forbidding any physician or other person who has attended or examined the proposed insured or may hereafter attend or examine the proposed insured from disclosing any knowledge or information thereby acquired and I hereby specifically authorize all such persons freely to communicate their knowledge to the company if it requests them to do so." There are other provisions following that but I do not believe that they are material. Therefore, I will not continue further at this time. And as I stated, the document is dated April 14, 1954, signed and dated at Whittier, California, signed George E. Gorey, applicant. I shall read briefly from Defendant's Exhibit A1. I believe it has the stamp of the clerk on the back.

The Court: Yes, the doctor's certificate.

Mr. Morrow: Doctor's report. It's entitled "Medical Examiner's Report to the National Life and Accident Insurance Company. (1) In connection with proposed application for insurance referred to on the reverse side hereof, I hereby certify that I am the person on whose life it is submitted." Signature of the proposed insured, signed "George E.

Gorey.” There are a number of questions shown on this exhibit. I [21] shall refer to only one. Question 8(f) “Has proposed insured ever undergone an electrocardiogram.” In parenthesis “Give details.” The answer is “No.” And then there is a certificate at the bottom reading as follows: I certify that I have examined George E. Gorey, Whittier, California, in private at my office this 20th day of April, 1954 for life insurance on his or her life and that proposed insured signed in my presence.” Signed S. H. Groff, M.D. Dr. Kerchner, will you take the stand, please.

DR. R. R. KERCHNER, SR.

called as a witness by and on behalf of the defendant, having been first duly sworn, was examined and testified as follows:

The Clerk: Will you state your name, please.

The Witness: R. R. Kerchner.

Mr. Morrow: I wonder whether I might turn this lecturn around, your Honor.

The Court: Yes, any way.

Direct Examination

Q. (By Mr. Morrow): Where do you reside, Dr. Kerchner? A. Montebello, California.

Q. And what is your home address?

A. 148 North 12th Street.

Q. And you have an office address?

A. 149 North Sixth Street. [22]

Q. The same city? A. The same city.

Q. You are licensed by the State of California to practice medicine? A. I am.

(Testimony of Dr. R. R. Kerchner, Sr.)

Q. And when were you licensed? A. 1936.

Q. Are you licensed to practice medicine in any other state besides California? A. I am.

Q. In what state? A. State of Ohio.

Q. When were you licensed to practice in the State of Ohio? A. 1929.

Q. Will you state whether or not you practiced medicine continuously at all times when you were admitted in the State of Ohio?

A. I practiced until I moved to California in 1936 from the State of Ohio.

Q. And thereafter you continuously practiced medicine in the State of California?

A. That's right.

Q. Will you state briefly what medical societies you belong to, Doctor, if any. [22a]

A. American Medical, California State Medical Association, Los Angeles County Medical Association, American Academy of General Practice, State Academy of General Practice, the County Academy, American Geriatrics Association, a few others that I can't recall just now.

Q. You are now engaged in the practice of medicine in Montebello, are you? A. I am.

Q. You were acquainted with George Edwin Gorey of Whittier, California, now deceased?

A. I was.

Q. How long were you acquainted with Mr. Gorey before his death? I might say he died in November '55.

A. I had known him for several years and I de-

(Testimony of Dr. R. R. Kerchner, Sr.)

livered his first baby for him. I can't tell you just what the age of that child is now, some 10 or 12 years, I guess. Not medically I didn't know him because I never treated him for any medical troubles until 1953.

Q. Then as I understand it, Mr. Gorey consulted you professionally at one time?

A. That's right.

Q. That was in October 1953?

A. That's right.

Q. Was that the first time Mr. Gorey had ever consulted you professionally? [23]

A. Yes.

Q. Did you make any notes or memoranda pertaining to that consultation in October 1953?

A. I did.

Q. Do you have them with you?

A. I have.

Q. Would you have to refer to the notes in answering some questions about the consultation?

A. Yes.

Q. What was the date of the first consultation of Mr. Gorey, Doctor?

A. October 21, 1953.

Q. And what complaint, if any, did Mr. Gorey have or make to you during the first consultation on October 21, 1953?

A. His complaint was pain, feeling of numbness particularly in his left arm. Upon heavy work and he was working around his place of occupation as a carpenter, climbing and things like that produced

(Testimony of Dr. R. R. Kerchner, Sr.)

excessive exertion would cause him to have this numbness and pain and that was what he was concerned about.

Q. Do your notes or memoranda show he had a pain anywhere other than his arm?

A. No, no, it did not.

Q. Do you recall whether or not he gave you a history of having had pain in his chest? [24]

A. He did. Symptoms of angina is what I thought. It was not of the chest but symptoms of angina means pain over the chest.

Q. Is it your recollection, then, that he complained of a pain in his chest at that time?

A. Yes, that's right.

Q. Approximately how long had Mr. Gorey had these complaints before the time he came for the consultation?

A. Just as I recall, I don't have specifically the day, but he started having this pain, as I recall it, it was approximately a month to six weeks prior to his coming to the office.

Q. And how many times did Mr. Gorey consult with you professionally about that complaint?

A. Three—two times other than that first time.

Q. In other words, a total of three times?

A. Three times.

Q. In regards to that complaint?

A. That's right.

Q. What were the dates of the other consultations in regard to that complaint, Doctor?

A. October 27, 1953, and October 31, 1953.

(Testimony of Dr. R. R. Kerchner, Sr.)

Q. Were the consultations held in your office in Montebello?      A. They were. [25]

The Court: Does the record show the age of the deceased at that time?

The Witness: He was 31 at that time.

The Court: 31?

The Witness: 31, yes, sir.

Mr. Morrow: I believe the application for insurance also shows the same, your Honor.

Q. On October 21, 1953, you obtained, as I understand it, from Mr. Gorey his medical history?

A. That's right.

Q. And you have already given us at least some of the medical history?      A. Yes.

Q. That he gave you at that time?

A. That's right.

Q. Was there any other complaint or history that he gave you other than what you have already stated at that time?

A. Would you please state that question again?

Mr. Morrow: Would you read the question, Miss Reporter.

(The requested portion read.)

The Witness: No.

Q. (By Mr. Morrow): Did you obtain Mr. Gorey's medical history for the purpose of diagnosing his complaint?      A. I did.

Q. And also treating his complaint, if that were [26] necessary?      A. That's right.

Q. Did you make any physical examination of Mr. Gorey in October '53?      A. I did.



(Testimony of Dr. R. R. Kerchner, Sr.)

Q. What examination or examinations did you make?

A. October 21 I made a complete physical examination from head to foot, as I usually do, eyes, ears, nose, throat, heart and lungs, stethoscopic examination, heart and lungs, abdomen, reflexes, prostate gland, urine test and so on, just general physical.

Q. As I recall you stated that the next consultation was on October 27, 1953?

A. That was his next visit to the office.

Q. You requested him to come in for that consultation, did you?           A. Yes, sir.

Q. For what purpose?

A. For the purpose of getting an electrocardiogram and chest X-ray.

Q. And was an electrocardiogram and chest X-ray taken of Mr. Gorey on October 27, 1953?

A. It was.

Q. Have you brought with you, Doctor, the electrocardiogram that was taken of Mr. Gorey on that day? [27]           A. I have.

Mr. Morrow: I believe you examined the document, Mr. McManus?

Mr. McManus: Yes.

The Court: Any objection to the offer?

Mr. McManus: No objection to the offer.

The Court: Received in evidence, Defendant's Exhibit B, Mr. Clerk.

The Clerk: Defendant's Exhibit B has previ-

(Testimony of Dr. R. R. Kerchner, Sr.)

ously been marked for identification, your Honor, and also offered.

The Court: I don't know whether they intend to use these two or not. This will be D.

Mr. Morrow: I haven't kept track as I should, Mr. Normandin. I believe it's C but I am not certain. We have only introduced, I believe, your Honor, A and A1 which are the application and medical report on back of the application.

The Court: You wish this one electrocardiogram marked D?

Mr. Morrow: I believe it would be proper to mark it B, if that meets with your Honor's approval.

The Court: The clerk has B marked for identification.

Mr. Morrow: D would be the next in order, then.

The Court: If you wish.

Mr. Morrow: That will be agreeable, your Honor.

The Court: Received in evidence. [28]

(The document referred to was received in evidence and marked Defendant's Exhibit D.)

Q. (By Mr. Morrow): After taking the electrocardiogram and the chest X-ray of Mr. Gorey, did you make any diagnosis of his condition?

A. I made a tentative diagnosis of coronary insufficiency, coronary heart disease. I was not thoroughly satisfied without consultation. I sent it to a specialist, electrocardiographer for consultation.

(Testimony of Dr. R. R. Kerchner, Sr.)

Q. As I understand it you sent the electrocardiogram then to a specialist for his opinion?

A. That's right.

Q. Who was the specialist, Dr. Kerchner?

A. Dr. Travis Windsor.

Q. He is a medical doctor?           A. M.D.

Q. What is his specialty, if any?

A. His specialty is heart, cardiac disease and electrocardiography.

Q. And by cardiography, what does that mean?

A. Science, the study of electrocardiographic tracing.

Q. Reading and interpreting such tracings?

A. That's right.

Q. Did you receive from Dr. Travis Windsor a report or an opinion? [29]           A. I did.

Q. Of Mr. Gorey's condition?           A. Yes.

Q. And you have the original report or opinion with you?           A. I do.

Mr. Morrow: We offer the same as an exhibit next in order for the defendant, your Honor. I believe it's stipulated, is it not, Mr. McManus, that the document is genuine?

Q. Do you have the document, Doctor?

A. My?

Q. Yes?           A. Yes, the original.

The Court: Have you seen it, Mr. McManus?

Mr. McManus: I am not sure I have seen this one.

The Court: It will be marked Defendant's Exhibit E for identification.

(Testimony of Dr. R. R. Kerchner, Sr.)

Mr. Morrow: I believe the statement, the preliminary statements—I will stipulate that that is a true copy of the—not a true copy but it is the original report and that the same may be admitted in evidence without the necessity of calling Dr. Windsor.

Mr. McManus: There is no objection to it.

The Court: Very well, pursuant to stipulation it is received in evidence as Defendant's Exhibit E.

(The document referred to was marked Defendant's Exhibit E for identification.)

Mr. Morrow: The document is very short. May I read it, your Honor?

The Court: You may.

Mr. Morrow: At the top, Travis Windsor, FACP, with his address in Los Angeles. "Electrocardiograms of Mr. George E. Gorey taken October 27, 1953. Description: Atrial and ventricular rate 70 beats per minute. P-R interval 0.16 second. QRS interval 0.07 second. Interpretation. Tracing is normal before exercise. However, after exercise negative ST. segment shifts in V4 are present. Those are very strongly suggestive of coronary insufficiency. This is an unusual situation for a boy of 31 years." Signed "Travis Windsor, M.D."

Q. Dr. Kerchner, when did you receive that document back from Dr. Windsor?

A. I don't have the date I received it. Some two or three days later.

Q. Was that before the last consultation you had with Mr. Gorey?

(Testimony of Dr. R. R. Kerchner, Sr.)

A. Yes, that was before October 31.

Q. 1953?           A. '53.

Q. And after receiving the report from Dr. Windsor, did [31] you make a final diagnosis of Mr. Gorey's condition?

A. I did.

Q. What diagnosis did you make at that time?

A. I made a diagnosis—while he was present I made the diagnosis of coronary heart disease of probably not too severe, that is, too far advanced, but there was no way of telling that to him definitely but I explained to him he did have this trouble and prescribed for him a regime of lighter work, less forceful exercise, discontinuing smoking and over-eating perhaps, anything that might produce increased rate of the heart which would likely bring on the pain which he experienced and which would cause him perhaps trouble.

Q. If I may interrupt you, did you explain to Mr. Gorey on October 31 or at least one of the visits your diagnosis was as you have prescribed?

A. I did.

Q. Will you explain briefly in so-called layman's language what coronary insufficiency means.

A. Coronary insufficiency means an insufficient amount of blood coming from the aorta through the coronary arteries. There are two arteries, one left and one right that encircle the heart coming over the top and around the heart that supply the blood to muscle of the heart which enables it to beat and when the heart does not supply enough blood or

(Testimony of Dr. R. R. Kerchner, Sr.)

the blood is not able to get through these arteries sufficiently then [32] pain develops because the muscle does not have enough oxygen which comes by way of the blood stream. That's coronary insufficiency.

Q. As I understand it, you diagnosed his condition as coronary artery disease?

A. Yes, that's what produces coronary insufficiency, coronary artery disease.

Q. Is there another medical term for that type of coronary artery disease?

A. Arteriosclerosis is the technical name, hardening of the arteries, hardening of the coronary arteries.

Q. It's coronary—— A. It's arteriosclerosis.

Q. It's coronary arteriosclerosis?

A. That's right.

Q. Did the electrocardiogram tracing in your opinion confirm your tentative diagnosis that Mr. Gorey was suffering from that condition and disease? A. It did.

Q. Were you aware in October, 1953, that Mr. Gorey was in the business of building and developing tracts?

A. I knew he was a carpenter in the building trade.

Q. And as I understand it, you advised him to lessen his physical activity? A. I did. [33]

Q. Did you prescribe any other treatment for him at that time?

A. I gave him a prescription for nitroglycerin

(Testimony of Dr. R. R. Kerchner, Sr.)

tablets to carry with him to be used as needed. If he developed a severe pain that lasted longer than just a few seconds, to take a nitroglycerin tablet under the tongue and I also advised him to come in in six months for another repeat electrocardiogram or before if his condition became more severe.

Q. Did Mr. Gorey consult you after October, 1953, with reference to that particular complaint or disease, namely, coronary arteriosclerosis?

A. He did not.

Q. Did he consult you professionally after October, '53 for any other complaint?           A. He did.

Q. Will you state the dates, please, and what the complaint was.

A. In March of 1954 he had an injury at work. He sprained his knee twisting while working and we had to aspirate his joint. He had hematosis or hemorrhage in the knee joint cavity. We had to withdraw blood from his knee. He was in three or four times, discharged April 7, March 24 to April 7 for the specific condition. On August 15, 1954, was the last I saw him professionally at which time he was complaining [34] of occipital headaches. Nothing about the heart at all. I prescribed niacin tablets for relief of his headache. I have one here. If not relieved, temporarily relieved at least with these tablets, he was to consult a neurologist for a further study from a neurological standpoint, which was a study of the nervous system.

Q. That's the last time you saw him professionally?

(Testimony of Dr. R. R. Kerchner, Sr.)

A. That's the last time I saw him, that's right.

Q. Dr. Kerchner, I have before me a certified copy of the death certificate of George E. Gorey dated November 21—strike that—it says it was received by the local registrar November 21, 1955, showing date of death November 19, 1955, 7:30 a.m. The certificate states "Disease or condition directly leading to death, (a) Acute Myocardial infarction; antecedent disease due to (b) coronary arteriosclerosis." Will you state briefly what acute myocardial infarction is, Doctor.

A. That is death of a portion of the heart muscle that is supplied by a branch or branches of the coronary artery that comes to that region and sometimes this branch is a large one, sometimes a small one. The injury involved is usually a complete death of the muscle with a development of scar tissue. If healing takes place, the patient survives. Infarction is a permanent thing. That muscle is dead. It never—the muscle cannot, doesn't regenerate. [35]

Mr. Morrow: Nothing else at the moment, your Honor. Just a moment, your Honor. No further questions, your Honor.

#### Cross Examination

Q. (By Mr. McManus): Dr. Kerchner, you prescribed nitroglycerin tablets for the patient. You don't know, however, whether he ever took one of those pills, do you?

A. That's right, I don't know that he did.



(Testimony of Dr. R. R. Kerchner, Sr.)

Q. And when you advised Mr. Gorey as to his physical condition, especially concerning his heart, did you tell him in lay terms or did you tell him in medical terms what was wrong with him?

A. I told him lay terms. I am certain of that.

Q. And when you testify in court now, are you able to recall all of this which occurred some two or three years ago from your own memory or are you testifying only from your records?

A. No. What do you mean, what part of this testimony, what I just now talked with you or with Mr. Normandin?

Q. The testimony which you have given this afternoon from the stand, is that—

A. The majority—the major portion of it is from the record. As to what words I spoke to him, I am just recalling from memory the essential part, like the advice I gave him, I gave him about advising him to stop smoking and [36] reduction of exercises and so on I have recorded but a large part of the things like description, what I told him about his heart, I am recalling just from memory only.

Q. You are able to recall now at this time what you told him?

A. I only because I do it to other people. I tell everybody. I have practiced the same with him as I have with others. I do not specifically recall that I showed him pictures of the heart but I show it to people who have this trouble, explain it to him.

Q. What I am trying to get at, Doctor, is not how you treat your other patients but how you

(Testimony of Dr. R. R. Kerchner, Sr.)

treat this particular patient, if you can remember of your own knowledge now what you told him at that time.

A. No, I can't remember exactly the words that I told him.

Q. But you do recall, do you, tell him that his condition was not too far advanced?

A. That's right.

Q. Is that your testimony?      A. That's right.

Q. And, as a matter of fact, you never can tell a heart patient that his condition is really bad, can you, Doctor?

A. That's right. We have to be very careful because of creating a neurosthenia or a cardiac invalid. The patient [37] is sometimes so worried about their heart, they then will have to be an invalid or their family will have them sick all the time, that they actually will feel sick. So we actually have to be very careful the way we tell them about it. Sometimes we can't even tell them. It is very very bad for them to give them that. It is a hardest thing to tell a patient exactly even if we know it. The electrocardiogram cannot always show exactly how severe this trouble is. It might have been very severe at that time. It might not have been, because the record only showed that he had this trouble after he exercised. If he hadn't exercised, we wouldn't know he had it at all.

Q. And the electrocardiogram is not always correct, is it, then?

(Testimony of Dr. R. R. Kerchner, Sr.)

A. If it is positive, yes, but negative the electrocardiogram isn't always correct.

Q. What I had reference to, Doctor, was the statement of Dr. Travis in which he said that the electrocardiogram was strongly suggestive of coronary insufficiency. Wouldn't that indicate that he wasn't positive that that was what was wrong with him?

A. Well, I don't know what Dr. Windsor had in mind other than what he stated there himself that you read from. I haven't talked with him about it. Of course, you have to know laboratory work is used in conjunction with clinical [38] findings, the history of a patient taken all combined to make a diagnosis. But the electrocardiogram is a pretty good thing. It has been pretty well established through all medicine that it is a safe thing to go by in the majority of cases at least.

Q. In the majority. In other words, it could on occasion be wrong, if possible?

A. It wouldn't be as pronounced. It wouldn't show up only on exercise. If he didn't have coronary artery disease, he would not have developed the findings, the segment shifts on exercise. I will have to say that was a positive finding. I don't think there is any question.

Q. You did advise another electrocardiogram?

A. Yes.

Q. After another six months?

A. That's right.

Q. Did he come back for an electrocardiogram?

(Testimony of Dr. R. R. Kerchner, Sr.)

A. No.

Q. He did come back to see you, though, professionally, did he not?      A. That's right.

Q. At that time did he make any complaint concerning his heart condition?      A. No.

Q. He did come back about six months after you first [39] saw him in October?

A. Let's see, October to March. That was about five months. May I say a word?

Q. Yes.

A. I saw George quite a number of times. I liked him very much. He was a nice fellow. We had him do quite a bit of work around the office, small jobs in carpentry work when he was off his own job and also at the house. He always acted perfectly all right. He never complained at all about his heart hurting him while he was around us. My wife saw him at the house and I saw him at the office. So personally, I—he was a fine, honest fellow as far as I could ever tell.

Q. Apparently he did the carpenter work for you. Was that after October '53?

A. Yes, yes. Oh, yes, all of this—the first time I saw him for years was October, 1953.

Q. How much after October, 1953 did he do the carpenter work for you?

A. I went to the hospital myself for quite a long stay in the hospital, about six weeks in October, '55. So I never saw him after that.

Q. Yes. What I have reference to, Doctor, was

(Testimony of Dr. R. R. Kerchner, Sr.)

he doing carpenter work for you immediately after October, 1953?

A. Well, I don't—I can't tell you whether it was a month after or—but many times—I will say 1953 [40] followed '53, '54 and '55, yes. I can't tell you how many times.

Q. Now, you said on direct examination that you advised for him to cut down on his exercises?

A. That's right.

Q. You mean at work or—

A. At any place. You remember I said excessive exercise or over-exercises.

Q. Oh, you told him to cut down on over-exercises? A. That's right.

Q. Not normal exercise? A. No.

Q. And the work which he did for you, you considered that to be not over-exercise?

A. That's right.

Q. Didn't you? A. That's right.

Q. And that wouldn't hurt him, would it?

A. No. Part of his livelihood.

Q. And you have nowhere in your notes, do you, Doctor, that Mr. Gorey ever lost any time from his work on account of his heart, do you?

A. No, I do not.

Q. And you don't remember him ever having told you he lost any time from that work, do you?

A. No, that's right, he never mentioned his heart as far as I can recall after 1953.

Q. Now, while you have stated, Doctor, that you advised him of his condition, do you think that it

(Testimony of Dr. R. R. Kerchner, Sr.)

is possible, perhaps, he did not recognize his true condition?

Mr. Morrow: Just a minute, objection, your Honor, calls for a conclusion and is argumentative.

The Court: Sustained.

Q. (By Mr. McManus): Could I see your notes, Doctor?      A. My history notes, you mean?

Q. Yes.      A. (Indicating.)

The Court: Just a single card?

The Witness: Yes.

The Court: Let it be marked as Plaintiff's Exhibit 3. Is it?

The Clerk: Yes, your Honor, or is it 2?

The Court: Yes, 3, Exhibit 3 for identification.

(The document referred to was marked Plaintiff's Exhibit 3 for identification.)

The Court: It has not been offered in evidence, Mr. McManus.

Q. (By Mr. McManus): Doctor, on your notes I notice under date of November 28, 1955, the patient—

Mr. Morrow: Just a minute, counsel. I object to your [42] reading notes of November, '55 as the doctor did not refresh his recollection of anything that occurred after, I believe it was August of 1955—of '54. I believe I am correct in stating that, your Honor.

Mr. McManus: Well, I am going to strike that question, your Honor.

Q. Now, I believe you told us on direct examination, Doctor, that in August, 1955, Mr. Gorey com-

(Testimony of Dr. R. R. Kerchner, Sr.)

plained of occipital headaches and that you prescribed medicine for him, is that correct?

A. That's right.

Mr. Morrow: May I interrupt a moment, your Honor. I believe August, 1954. Is that correct?

Mr. McManus: Isn't that what I said?

Mr. Morrow: You said '55, I believe.

Mr. McManus: '54, then.

Q. Now, did he make any complaints to you at that time concerning his heart?

A. So far as I can remember, he did not make any complaints of his heart after I last saw him and he had his consultation on October 31, I believe it was, in 1953, I don't think he ever said anything about his heart.

Q. And what kind of examination, if any, did you give him in August, 1954?

A. That, I don't remember. I know my notes are very [43] brief. I was ailing at the time and couldn't much practice. I couldn't do a great deal of detail writing.

Q. You don't remember whether you actually examined his heart at that time or not?

A. No, I don't recall. Anyway, coronary heart disease cannot be heard by stethoscope anyway.

Mr. McManus: I believe that will be all, Doctor.

Mr. Morrow: No further questions, your Honor.

The Court: You may step down, Doctor. Next witness.

Mr. Morrow: The Doctor may be excused?

Mr. McManus: Yes, he may be excused.

The Court: Now, the Doctor's notes here have been marked for identification as Exhibit 3. If both sides agree that they may be withdrawn——

Mr. Morrow: It is perfectly agreeable with the defendant.

Mr. McManus: I would like to offer them in evidence.

Mr. Morrow: We would object to the receipt in evidence. They were only used to refresh his recollection; counsel was given the opportunity to cross examine the doctor on all dates and matters in question. We object to——

The Court: Overruled. They will be received in evidence, Exhibit 3.

Mr. Morrow: Furthermore, may I be heard on another ground.

The Court: You may state another ground.

Mr. Morrow: The other ground is that the notes have to [44] do with not exclusively Dr. Kerchner, Sr. There are some notes down there by Dr. Kerchner, Jr.

The Court: That doesn't appear in the record here so far as I recall. The Doctor identified them as his notes. We have the testimony of the Doctor as being his notes. I don't recall hearing any mention of anyone else.

Mr. Morrow: Might I, before you affirmatively rule, recall Dr. Kerchner to clarify that question?

The Court: Any objection?

Mr. McManus: No, I have no objection.

The Court: You may.



Mr. Morrow: Will you take the stand again, please, Doctor?

The Court: Exhibit 3.

DR. R. R. KERCHNER, SR.

recalled as a witness on behalf of the defendant, having been previously duly sworn, testified further as follows:

Redirect Examination

Q. (By Mr. Morrow): You have your notes before you, Dr. Kerchner? A. I do.

Mr. Morrow: Exhibit 3, is it, Mr. Clerk?

The Clerk: Yes.

Mr. Morrow: For identification.

Q. Dr. Kerchner, there is entered 8/15/54 which you [45] have testified about on your notes. Is that in your handwriting? A. That is.

Q. And is there other handwriting following that date? A. There is.

Q. Is any of the following handwriting in your handwriting? A. It is not.

Q. Whose handwriting is it, if you know?

A. It's my son's, Dr. R. Kerchner, Jr.

Mr. Morrow: If the Court, please, we object to the introduction of the document in evidence on the same grounds, it is not entirely the handwriting of the Dr. Kerchner, no foundation laid showing the value of the material, furthermore, anything stated on there would be purely hearsay.

The Court: Doctor, any testimony you have given of events subsequent to the 1954 dates you mentioned, you looked at Exhibit 3 and refreshed

(Testimony of Dr. R. R. Kerchner, Sr.)

your recollection from your notes of entries made by yourself, have you relied upon entries made by yourself?

The Witness: Yes, sir.

Mr. Morrow: May I examine the Doctor further on that matter?

The Court: You may.

Q. (By Mr. Morrow): Doctor Kerchner, as I understand you to say, you refreshed your recollection on the notes on [46] Exhibit 3 for some notes appearing after 8/15/54?      A. That's right.

Q. In your testimony of today?

A. You say—I didn't testify about the notes today, no.

Q. Did you incorporate in your testimony today any matter that is shown in handwriting that is other than your own?      A. I would hate to.

Q. No, I say, did you?

A. Did I? I did not.

Q. In other words, as I understand you, you refreshed your recollection and testified only from the entries on Exhibit 3 starting 10/21/53 and ending 8/15/54?      A. That's right.

Mr. Morrow: If the Court, please——

The Court: You misunderstood me. I asked you if you had relied upon your son's entries in giving your testimony. I understood you to say you did.

The Witness: I beg your pardon. I didn't understand it. No.

The Court: Your testimony is you did not refresh

(Testimony of Dr. R. R. Kerchner, Sr.)

your recollection, any part of your recollection, from any entries made by your son?

The Witness: That's right.

Mr. McManus: May I ask a question, your Honor? [47]

Recross Examination

Q. (By Mr. McManus): Doctor, will you state the name of the doctors who are in your office?

A. At the present time?

Q. At the time that these notes were made.

A. R. Kerchner, Jr. and myself.

Q. And yourself? A. And myself.

Q. And were these notes made in the regular course of your business?

A. All of them? You are speaking of all the notes now?

Q. I am speaking about all the notes.

A. All the notes——

Mr. Morrow: Just a minute. I object. It calls for a conclusion so far as any other notes have been made, your Honor, except the ones Dr. Kerchner, Sr. made.

The Court: Overruled. You may answer.

The Witness: The notes that I made myself here are all my own and were made in the course of my practice.

Q. (By Mr. McManus): And were the notes which were made by your son made in the course of your general practice?

A. They were. I could vouch for that.

Mr. Morrow: If the Court, please, we renew our

(Testimony of Dr. R. R. Kerchner, Sr.)

objection on the additional ground I have already stated that some [48] of the matters that occur after 8/15/54 would be purely hearsay. I suggest that the Court may examine the notes.

Mr. McManus: Well, I believe that should be admitted, your Honor. I have no objection to the Court examining the notes.

Mr. Morrow: We would be happy to stipulate that the only notes that this witness has testified about, refreshed his recollection be read into evidence. We have no objection to that but there are some hearsay matters that have nothing to do with this case, which we object.

The Court: Well, objection sustained. Exhibit 3 will be marked for identification only. Do you desire it to remain in the record?

Mr. McManus: Yes, your Honor.

The Court: Very well, Exhibit 3 will remain in the record as a record of excluded evidence, 3.

Mr. Morrow: We renew our offer that we have no objection to the reading of the items 10/21/53.

The Court: Offer was made of the entire exhibit.

Mr. Morrow: In addition to that, I offer, if counsel agree in this, we will stipulate that part may be read.

The Court: The offer was of the entire record. I sustained your objection, Mr. Morrow. Any further questions from the doctor.

Mr. McManus: I have no further questions. [49]

The Clerk: I want to keep these exhibits straight.

(Testimony of Dr. R. R. Kerchner, Sr.)

D was supposed to be the electrocardiogram. I don't know where that is.

The Court: Where is Exhibit D, the electrocardiogram?

The Witness: Here it is, right there.

The Court: Exhibit E is Dr. Windsor's report. You have Exhibit 3 marked for identification, the objection of the defendant's counsel being sustained. No further questions of Dr. Kerchner?

Mr. Morrow: No further questions.

Mr. McManus: No further questions.

The Court: You may step down. You are excused. Call your next witness.

Mr. Morrow: We have some sworn documents to offer at this time. I believe we have some of these documents here in our file.

The Court: It might be well to take the afternoon recess at this time while you gentlemen are assembling those matters. Again before we separate, members of the jury, I must admonish you you are not to converse or otherwise communicate among yourselves or with anyone else upon any subject touching upon the merits of the trial, not to form or express any opinion on the case until it is finally submitted to you for your verdict. I will excuse you for five minutes.

(Whereupon a short recess was taken.) [50]

The Court: Is it stipulated, gentlemen, that the jury is present?

Mr. Morrow: Yes, your Honor.

Mr. McManus: Yes, sir.

The Court: You may proceed.

Mr. Morrow: Call Mr. Smith, please.

LAWSON W. SMITH

called as a witness on behalf of the defendant, being first duly sworn, was examined and testified as follows:

The Clerk: Will you state your name, please.

The Witness: Lawson W. Smith.

Direct Examination

Q. (By Mr. Normandin): Where do you reside, Mr. Smith?      A. 415 Divester Drive, Whittier.

Q. What is your occupation?

A. District manager and administrative officer of the district.

Q. Of what company?

A. National Life and Accident Insurance Company.

Q. That is the defendant in this case, is it not?

A. That's correct, sir.

Q. How long have you been engaged in that position with the defendant company?

A. A little over six years. [51]

Q. Mr. Smith—

Mr. Normandin: Pardon me, Mr. Clerk, would you hand Mr. Smith Defendant's Exhibit A?

Q. (Continued) Does the National Life & Accident Insurance Company issue policies on lives of various individuals?

A. Would you repeat that, please?

(Testimony of Lawson W. Smith.)

Mr. Normandin: Read it, please, Miss Reporter.

(The requested portion read.)

The Witness: They do.

Q. (By Mr. Normandin): Before any policies are issued, do you have any jurisdiction over securing applications for the policy?

A. Yes, there is a procedure which we follow in securing applications.

Q. And what is that procedure, Mr. Smith?

A. On the application certain questions are set forth and the proposed insured or the applicant is asked these questions and the information is put on the application as answered by the applicant.

Q. Now, you have before you Defendant's Exhibit A. Is that a form which is used by your company?

A. It is, sir.

Q. And for what class of insurance policies is that used?

A. For preferred risk. [52]

Q. Calling your attention to the portions on that application, Defendant's Exhibit A, will you state for what purpose part 1 is used?

Mr. McManus: I am going to object to that as calling for a conclusion of the witness.

The Court: In that form I will sustain the objection. Does the form need explanation?

Mr. Normandin: I believe it does, your Honor, with reference to certain particular questions that are included in the application as to the materiality of the particular information that is sought in response to those questions, your Honor.

(Testimony of Lawson W. Smith.)

The Court: You expect to show that this was communicated to the insured, the decedent?

Mr. Normandin: The decedent executed the application.

The Court: Yes, I know, but he might not know what purpose the company had in the certain portion of the form. Unless you expect to connect it up with him, the objection is sustained.

Q. (By Mr. Normandin): Mr. Smith, were you familiar with any matters having to do with the claim which is made by Mrs. Gorey in connection with the application and the policy of insurance, Plaintiff's Exhibit 1?

A. Does this refer to any part of 1? It refers to A-1.

The Court: Exhibit 1 is the policy. [53]

Q. (By Mr. Normandin): Exhibit 1 is the policy.

A. I recall notice of death coming into the office and seeing that proof of claim was completed to forward to our home office.

Q. Do you know whether or not any payment was sent by the home office to you to transmit to the plaintiff, Mrs. Gorey, on that policy?

A. It was, sir.

Q. How much was that?

A. The exact amount I don't recall but I can give it to you in general. It was a refund of all premiums plus interest.



(Testimony of Lawson W. Smith.)

Q. And was that in the form of a check of the company's office at Nashville? A. It was, sir.

Q. Do you know what happened to that check?

A. It was delivered to the beneficiary, Mrs. Gorey.

Q. By whom? A. By myself, sir.

Q. However, you understand, do you not, Mr. Smith, that that check was never cashed?

A. I heard such.

Q. After the issuance of the insurance policy, Plaintiff's Exhibit 1, did you, in your office as the district manager, ever receive any information or communication from Mr. Gorey or anyone else in his behalf, that any of the answers in the [54] original application were not correct?

A. No information or communication was ever received in the district to my knowledge.

Q. Have you made a search of your records?

A. I personally have.

Q. To ascertain whether or not any communication was ever received?

A. I personally checked that prior to the submission of the claim to the home office, sir.

Q. What was the result of your search?

A. It was negative.

Q. Did you personally have any information at all with reference to the matter of Mr. Gorey having been before Dr. R. R. Kerchner in October, 1953? A. Prior to claim, none.

Mr. Normandin: You may cross examine.

(Testimony of Lawson W. Smith.)

Cross Examination

Q. (By Mr. McManus): Mr. Smith, on the exhibit marked A-1, you say that the agent asked questions of the proposed insured and then the agent put the answers down himself?

A. A-1, is that the doctor's statement?

Q. A-1 is the doctor's statement. I see.

A. That's correct.

The Court: Isn't the reverse side A-1 the application? [55]

The Witness: Yes, sir, that's part 4 that is marked Exhibit A, sir. Exhibit A.

The Court: Exhibit A is the original application. That's what you are referring to?

Mr. McManus: That's what I am referring to, your Honor. I am sorry.

Q. Now, referring to Exhibit A, the application, Mr. Smith, did you say on direct examination that the agent asked the questions of the proposed insured and then the agent writes the answers down on the form, is that correct?

A. That's the procedure.

Q. And then after the agent has written all of the answers down, the proposed insured signs the form, is that correct?

A. He is requested to review the questions which he has answered and if found correct, then to sign the application.

Q. And in this particular case you have no information whether or not he was asked to review it or not, do you?      A. No, I do not.

(Testimony of Lawson W. Smith.)

Q. Do you know that is Mr. Gorey's signature, though, don't you?

A. Well, I have every reason to believe it is.

Q. And are the answers on that form written in the handwriting of agent Haws, I believe it is?

A. That's correct, sir.

Mr. McManus: Nothing else. [56]

Mr. Morrow: May I have just a moment, your Honor? No further questions.

The Court: You may step down.

Mr. Morrow: At this time, your Honor, we would like to offer I believe they are exhibits B and C for identification. You have seen these, I believe?

Mr. McManus: I believe so.

(The documents referred to were marked Defendant's Exhibits B and C, respectively, for identification.)

Mr. Morrow: We offer the Exhibits B and C for identification in evidence, your Honor.

The Court: What are they?

Mr. Morrow: They are the physician's statement and notice of proof of loss, I believe they are entitled.

The Court: Any objection?

Mr. McManus: No objection.

The Court: Stipulated to be genuine in all respects what it purports to be?

Mr. McManus: Yes.

The Court: There will be received in evidence physician's statement—perhaps I better clarify that.

Is that the company's physician, insurance company's physician?

Mr. Morrow: No, your Honor, Dr. Kerchner who testified a while ago—that particular statement is signed by Dr. Kerchner, Jr., I believe. [57]

The Court: That's the statement made after the death of the insured?

Mr. Morrow: Yes, your Honor.

The Court: In connection with the claim of loss?

Mr. Morrow: Yes, your Honor, was furnished after the insured died by the plaintiff. Is that right, Mr. McManus, furnished to the company?

Mr. McManus: Yes.

The Court: Very well. That is Exhibit B, is it?

The Clerk: No, that's Exhibit C, your Honor.

The Court: Exhibit B is the claim itself, claimant's certificate?

Mr. Morrow: Claimant's certificate, the claim being of the plaintiff in this action. Am I correct, Mr. McManus?

The Court: In other words, Exhibit C is the claim that the plaintiff here presented to the insurance company after the death of her husband, is that correct?

Mr. McManus: Yes, that's correct.

The Court: And Exhibit B is the physician's statement accompanying that claim?

Mr. McManus: Well, B seems to be something that's signed by the plaintiff, Verda Gorey.

The Court: B then, is the claim of the plaintiff and C is the physician's statement, is that it, which accompanies the claim? [58]

Mr. McManus: Yes, that's correct.

The Court: Very well.

Mr. Morrow: I would like to read briefly from the exhibits when they are marked, your Honor.

(The documents referred to marked Defendant's Exhibits Nos. B and C, were received in evidence.)

The Court: Very well, you may.

Mr. Morrow: Reading from Exhibit B, which is entitled notice of claim, proof of death, claimant's certificate, which has been stipulated, I believe, is signed by the plaintiff, Verda A. Gorey, dated November 21, 1955—I will not read the entire document, Question—pardon me just a moment, sir. I will proceed, your Honor. I am sorry for the interruption. Question 5 of the form I just referred to signed by the plaintiff, referring to George E. Gorey, the deceased, the question is "Cause of death," Answer, "Heart attack." On Exhibit C, which is entitled proof of death, attending physician's certificate signed by R. R. Kerchner, Jr., M.D., which it has been stipulated was furnished to the defendant company after Mr. Gorey died in connection with the claim made on his policy, Question 6, "Date of death." "11/19/55." Question 7, "Immediate cause of death," "Myocardiac infarction." Question 8, "Contributory causes of death," "Arteriosclerosis." Question 10, "How long were you the deceased's medical adviser," Answer "This office, [59] (R. R. Kerchner, Sr., M.D.) for 25 months," Question 11, "When were you first consulted for the condition which directly or in-

directly caused death," Answer, "October 21, 1953," Question 12, "Date of your last visit in final illness," Answer, "October 25, 1955," and below that the word "about," Question 13, "Names and addresses of all other attending physicians during final illness," Answer "R. R. Kerchner, Sr., M.D." with his address "149 North Sixth Street, Montebello, California," Question 14, "In your opinion how long did deceased suffer from the disease or impairment," Answer "25 months," Question 15, "Give duration of each contributory disease as accurately as you can using dates," Answer, "Coronary arteriosclerosis 25 months," signed "R. R. Kerchner, Jr., M.D.," dated "11/21/55." Pardon us just a moment, your Honor. I have here a document entitled "Retail Credit Company life report." May I show same to counsel, your Honor? I am not certain he has seen that. We offer this document in evidence, your Honor. It's dated 4/19/54. I understand Mr. McManus has no objection.

Mr. McManus: I have no objection.

The Court: Stipulated to be genuine in all respects what it purports to be?

Mr. McManus: Yes, it is, your Honor.

The Court: Received in evidence, Exhibit F?

The Clerk: Yes, your Honor, Exhibit F. [60]

(The document referred to was marked Defendant's Exhibit F and received in evidence.)

Mr. Morrow: If the Court please, we have a deposition of two witnesses who are officers of the company in the home office and we should like to read same in evidence if it meets with your Honor's

approval. We take it that's the proper way to proceed in that matter.

The Court: Yes. The original is filed?

Mr. Morrow: I believe so, your Honor. Perhaps I should read from the original.

The Court: Yes. Is there any objection to the deposition?

Mr. McManus: No objection.

The Court: They may be received in evidence, then. Are they under one cover?

Mr. Morrow: They are under one cover.

The Court: They will be received in evidence as Defendant's Exhibit G and G-1.

The Clerk: Your Honor, there are four envelopes here each containing a deposition, one deposition, according to the entry.

Mr. Morrow: We can identify which ones we refer to. They are Jack D. Gwaltney and Dr. Lloyd C. Miller, I believe taken August 3, 1956 in Nashville, Tennessee.

The Court: Do you have those, Mr. Clerk?

The Clerk: Yes, your Honor. The date they are taken is [61] not shown on the envelope. It says deposition of Jack D. Gwaltney and Dr. Lloyd C. Miller.

The Court: Will you open that? They are under one cover, Mr. Clerk?

The Clerk: Yes, your Honor.

The Court: Which is the first deposition, Gwaltney?

The Clerk: Yes, your Honor.

The Court: That will be received in evidence as

Defendant's Exhibit G and the other is Dr. Miller, is it?

The Clerk: Yes, your Honor.

The Court: It will be received in evidence as Defendant's Exhibit G-1.

(The documents referred to were marked Defendant's Exhibits G and G-1, respectively, and received in evidence.)

Mr. McManus: Now, may the plaintiff have the reservation to make objections when the deposition is read? I understand counsel intends to read the deposition?

The Court: Yes. I understood you had no objection to it. That's the reason I received it in evidence. They will be marked Exhibit G for identification and Exhibit G-1 for identification instead of in evidence.

(The documents referred to heretofore received in evidence as Defendant's Exhibits G and G-1, respectively, were withdrawn from evidence and marked for identification as Defendant's Exhibits G and G-1, respectively, for identification.) [62]

The Court: You may proceed, gentlemen.

Mr. Normandin: (Reading.)

"The Depositions of Jack D. Gwaltney and Dr. Lloyd C. Miller, taken on behalf of the Defendant, at 11:00 o'clock A.M., on Friday, August 3, 1956, at Room 112, National Building, 301 Seventh Avenue, North, Nashville 3, Tennessee, before T. Roy Hix, Notary Public, in and for the County of Davidson, Tennessee, pursuant to the annexed Notice.



“Appearances: For the Plaintiff: (No appearances.) For the Defendant: Walter M. Robinson, Jr., National Building, Nashville 3, Tenn.

“JACK D. GWALTNEY

the first witness, being first duly sworn, deposed as follows:

Direct Examination

“By Mr. Robinson:

“Q. Please state your name.

“A. Jack D. Gwaltney.

“Q. Where do you live, Mr. Gwaltney?

“A. I live at 2133 June Drive, Nashville 14, Tennessee.

“Q. How old are you?

“A. I am 28 years old. [63]

“Q. By whom are you employed?

“A. I am employed by The National Life and Accident Insurance Company, at its Home Office in Nashville, Tennessee.

“Q. How long have you been employed by that Company? “A. Since January 23, 1950.

“Q. What is your present position?

“A. I am a Senior Underwriter in the Ordinary Underwriting Department.

“Q. How long have you been employed in that position?

“A. About two and one-half years, and before that I was a Junior Underwriter in the Ordinary Department.

“Q. What is the general nature and scope of your duties and authority as a Senior Underwriter?

(Deposition of Jack D. Gwaltney.)

“A. My general duties are the underwriting of applications for ordinary life insurance. Underwriting is the selection of risks. My duties include the review of applications made to the Company for the issuance of policies of ordinary life insurance to determine whether the applicant is eligible for the policy he is applying for; and I have authority to approve applications for the issuance by the Company of ordinary life insurance policies up to \$10,000.00 principal [64] amount when I determine that the applicant is eligible for the policy applied for.

“Q. During April, 1954, were you engaged in those duties and did you then have such authority last mentioned? “A. Yes.

“Q. I hand you here a document entitled ‘Application for Insurance to The National Life and Accident Insurance Company’. Will you state what that document is?

“A. This is the application of George E. Gorey to The National Life and Accident Insurance Company for the issuance of an ordinary life insurance policy on the life of George E. Gorey on the Family Income plan. The application is dated April 14, 1954 and was submitted through our Montebello, California District Office.

“Q. Have you ever seen that document before?

“A. Yes, on April 29, 1954, I approved this application for issuance of the policy of insurance applied for. As that time, there was not attached to it either the slip bearing the case No. 19691 WM, with the following data: ‘Gorey vs. National Life,

(Deposition of Jack D. Gwaltney.)

Deft's Exhibit A, No. A Identification' nor the slip bearing the case No. 19691 WM, with the following data: 'Gorey [65] vs. National Life, Deft's Exhibit A-1, No. A-1 Identification'.

"Mr. Robinson: Mr. Reporter, will you affix your initials and this date on this application, and secure and attach to this deposition a photostatic copy of each page of said application?

"(The document referred to was so initialed and dated by the reporter, and a photostatic copy of each page is attached herewith.)

"By Mr. Robinson:

"Q. Now, Mr. Gwaltney, referring to that application, was a policy of life insurance of the type and character applied for ever issued by your Company pursuant to said application? "A. Yes.

"Q. Does that application show the number of the insurance policy which was issued pursuant thereto?

"A. Yes, the number appears in the upper left-hand corner of the inside page, and it is 2081957.

"Q. Did you make any marks on that application?

"A. Yes, in the box on the bottom of the right side of the outside page I circled the words 'Approved' and filled in the date '4/29/54' and my initials 'JDG'. I also made the two symbols 'O' and the letter 'A' in the column under the printed word 'Rating' and I drew [66] a line under the initials 'JDG'. I also placed the numeral 'III' in the column under the printed word 'Code'.

(Deposition of Jack D. Gwaltney.)

“Q. Are said initials ‘JDG’ your initials?

“A. Yes.

“Q. Does the line under your initials have any significance?

“A. Yes, that line indicates that my action in approving this application was final and that the policy was ready for issue.

“Q. What is the significance of the symbols, letter and numeral, ‘O’, ‘A’ and ‘III’ respectively, which you placed on said application?

“A. The ‘O’ means that the applicant was given the standard rating on the Life and the Waiver of Premium features; the ‘A’ means that he was given a rating of ‘A’ on his double indemnity rider by reason of his occupation as builder, developer and carpenter; and the ‘III’ refers to the reason for the ‘A’ rating, which reason is the occupation of the insured.

“Q. What was the occupation of the insured?

“A. The application, the medical examiner’s report and the inspection report indicate that he was a builder, developer and carpenter.

“Q. In passing upon this application, what information [67] did you have available?

“A. I had only the statements of the applicant in his application, the information revealed in said application and in the medical examiner’s report, and the information revealed in the inspection report.

“Q. When you mentioned ‘inspection report’, to what did you refer?

(Deposition of Jack D. Gwaltney.)

“A. I referred to the report of the Retail Credit Company relating to George Edwin Gorey, dated 4/19/54.

“Q. I hand you here a document entitled Retail Credit Company, Life Report, Acct. No. 482, dated 4/19/54, showing the name and address of George Edwin Gorey in the upper left portion thereof. Will you state what that document is?

“A. It is what we refer to as an inspection report. It is the report made by the Retail Credit Company to our company concerning George E. Gorey, the insured named in the insurance policy in suit.

“Q. Have you ever seen this document before?

“A. Yes, on or about April 21, 1954. It was received in our Home Office and was referred to me.

“Mr. Robinson: Mr. Reporter, will you affix your initials and this date in the upper right-hand corner of the document and also secure and attach to this deposition a photostatic copy of said document?

“(Document referred to was so initialed and dated by the reporter, and a photostatic copy of each page is attached herewith.)

“By Mr. Robinson:

“Q. In passing upon and approving the application for the policy on the life of Mr. Gorey, upon what information did you rely?

“A. I relied only upon the statements of the applicant in his application, the information revealed in that application and in the medical examiner's

(Deposition of Jack D. Gwaltney.)

report and the information revealed in the inspection report.

“Q. Assuming the truthfulness of the statements of the applicant in his application, and of the information revealed in that application and in the medical examiner’s report, and of the information revealed in the inspection report, was the applicant eligible for the policy of insurance he applied for?”

“A. Yes.

“Q. Suppose that the application contained statements that during October, 1953, the applicant had consulted a physician for a pain in his chest and a numbness and tingling of the arm and hand, and that physician diagnosed the condition as coronary artery disease, a type of heart disease, and that the physician [69] had made an electrocardiogram of Mr. Gorey and confirmed his diagnosis, what would have been your action on the application?”

Mr. McManus: I believe I am going to object to that question for the reason that it calls for the opinion of an employee as to what he would have done under certain circumstances and it calls for a conclusion of the witness.

Mr. Normandin: The answer to that, if your Honor please, this witness who is testifying by deposition is——

The Court: It’s offered for the purpose of showing what?

Mr. Normandin: Offered for the purpose of showing that had he the facts——

(Deposition of Jack D. Gwaltney.)

The Court: Reliance, is that it?

Mr. Normandin: Relied upon——

The Court: Reliance, is that the purpose?

Mr. Normandin: Yes, your Honor.

The Court: Is reliance in issue here?

Mr. McManus: We have already——

The Court: Is reliance in issue? Have you raised that, Mr. Normandin?

Mr. McManus: Pardon me, your Honor, we have already stipulated, your Honor, that the defendant relied upon the application and upon the medical report and upon——

The Court: Then there is no occasion for this, is there? It's covered by the stipulation. Do you agree there is a [70] stipulation on it?

Mr. Normandin: Well, I understand we entered into a stipulation, your Honor, at the time——

The Court: Objection sustained.

Mr. Morrow: May I confer a moment with Mr. Normandin, your Honor?

The Court: Yes. Is the stipulation reliance both on what was said and what was not said?

Mr. Normandin: I don't believe so. There might be a doubt.

The Court: I reverse the ruling. You may proceed. I will overrule the objection.

Mr. Normandin: I will ask the reporter to read the last question.

(The requested portion read.)

Mr. Normandin: "A. I would have marked the application to indicate that the applicant was not

(Deposition of Jack D. Gwaltney.)

insurable by our Company and would have forwarded it to our Medical Department. In other words, I would not have approved the application for that policy.

“Q. What effect would have resulted had it been known to your Company that the applicant had been diagnosed as having coronary artery disease, a type of heart disease, in October, 1953?

“A. It would have resulted in establishing that [71] he was an uninsurable risk for life insurance by our Company.

“Q. After the issuance of said policy No. 2081957, and during the lifetime of Mr. Gorey, was any communication received by your Company at its Home Office from Mr. Gorey, or any other person, relating to any of the answers to the questions set forth in his application for said policy?

“A. No.

“Q. During that period did you receive or hear of any such communication? “A. No.

“Q. If any such communication had been received by the Company at its Home Office, to whom would the same have been referred to consideration?

“A. To me as the Senior Underwriter who approved and passed upon the application.

“Q. Have you examined the papers, records and files of the Home Office of your Company, and in particular the file concerning the policy in suit, to ascertain whether or not they contain any communication received during the lifetime of Mr. Gorey



(Deposition of Jack D. Gwaltney.)

from him or from any other source, relating to any of the answers to the questions set forth in his application for said policy, or relating to the fact that before [72] applying for the policy, Mr. Gorey had consulted a physician, or to the fact that he had coronary artery disease or heart disease, or that a physician had advised him that he had coronary artery disease or heart disease?

“A. Yes.

“Q. Did you find any such communication?

“A. No.”

Then the signature, “Jack D. Gwaltney.”

“Sworn to and subscribed before me, this 13th day of August, 1956.

“T. Roy Hix, Notary Public, State of Tennessee at Large.

“My Commission Expires April 23, 1958.”

That completes the deposition of Mr. Gwaltney, your Honor. May I continue? The following page contains the deposition, and subsequent pages, of:

“DR. LLOYD C. MILLER

the second witness, being first duly sworn, deposed as follows:

“Direct Examination

“By Mr. Robinson:

“Q. State your name.

“A. Lloyd C. Miller.

“Q. Where do you live, Dr. Miller? [73]

“A. I live at Howell Place, Nashville 5, Tennessee.

(Deposition of Dr. Lloyd C. Miller.)

“Q. How old are you?

“A. I am 57 years old.

“Q. Please state your educational background.

“A. I was graduated from Washington University Medical School, St. Louis, Missouri, in 1925 and was in general medical practice until 1934, when I became Associate Medical Director of the General American Life Insurance Company of St. Louis.

“Q. By whom are you now currently employed?

“A. By The National Life and Accident Insurance Company, at its Home Office in Nashville, Tennessee.

“Q. What is your current position with that company?

“A. I am now Medical Director of that company, having recently been appointed to that position.

“Q. How long have you been employed by that Company?

“A. Since March 10, 1941, when I was appointed Associate Medical Director. I served in that capacity until my recent appointment as Medical Director.

“Q. Then in April, 1954, you were the Associate Medical Director of The National Life and Accident Insurance Company at its Home Office in Nashville, Tennessee? [74]      “A. Yes.

“Q. What was the general scope of your authority and duties in 1954 in that position?

(Deposition of Dr. Lloyd C. Miller.)

“A. As Associate Medical Director of the Company in 1954, I had authority to approve or reject applications for the issuance of ordinary policies of life insurance; and my duties included the supervision of underwriting of applications for ordinary life insurance policies, especially medical questions arising in the course of underwriting.

“Q. Did you personally see each application for ordinary insurance submitted to the Company?

“A. No, the applications are first reviewed in the Company’s Ordinary Underwriting Department. If the Underwriter to whom the application is submitted determines that the applicant is eligible for the policy applied for, the policy would be approved for issuance without my ever having seen the application. If there was any question whether or not the applicant was eligible for the policy applied for, the application would be referred to me.

“Q. I hand you here a document entitled ‘Application for Insurance to The National Life and Accident Insurance Company’ on which the reporter has affixed his initials and this date. State whether or not you [75] participated in the underwriting of this application.

“A. No, I did not. This application was approved for issuance by Mr. Jack D. Gwaltney, Senior Underwriter in the Ordinary Underwriting Department of the Company.

“Mr. Robinson: Mr. Reporter, will you secure and file a photostatic copy of each page of that application?

(Deposition of Dr. Lloyd C. Miller.)

“(Photostatic copy of each page of document referred to so filed and attached herewith.)

“By Mr. Robinson:

“Q. Suppose that that application had been referred to you and it revealed that during October, 1953, the applicant had consulted a physician for a pain in his chest and a numbness and tingling of the left arm and hand, that said physician diagnosed the condition as coronary artery disease, a type of heart disease, and that the physician had made an electrocardiogram of Mr. Gorey and confirmed his diagnosis, what would have been your action on the application?”

Mr. McManus: I believe that I will make the same objection to that question as I made to the other one, your Honor, that it calls for the opinion of an employee of the defendant as to what he would have done under certain circumstances.

The Court: This witness does not say he took any action [76] at all on it.

Mr. Normandin: No, except he has authority.

The Court: Yes, I understand, but it never got to him.

Mr. Normandin: That's correct.

The Court: It would be purely speculative.

Mr. Normandin: Might I be heard, your Honor?

The Court: The other witness said he did act upon it. In order to show reliance, he may say what he testified about, with respect to what he would have done under certain circumstances, but this is a witness to whom it never came.

Mr. Normandin: But, if your Honor please, this witness is the one to whom matters of this kind would have been referred had it been disclosed and he is the one who would have the sole power of passing upon the question if the information had been set forth.

The Court: Just the same, it's speculative.

Mr. Normandin: The balance of the deposition, I might state, your Honor, repeats other questions calling for the same type of responses, your Honor, and is made to meet the allegations of the defendant's answer that had it known of the facts as revealed by the testimony itself here today, the Company would not have issued its policy. I might make an offer of proof at this time, if your Honor please, for the record.

The Court: The evidence here in the form of a deposition, [77] Defendant's G-1 for identification and is part of the record.

Mr. Normandin: Your Honor, there are certain exhibits referred to in the depositions and the originals are in evidence, but photostatic copies are attached to the deposition itself. That completes the depositions, your Honor.

The Court: Very well.

Mr. Morrow: If the Court please, we have some interrogatories of the president of the defendant company that perhaps would be—if counsel is willing to stipulate that all of the questions and answers may be read into evidence, I take it it would consume some ten minutes of time.

The Court: Suppose you go ahead. If there is a chance of concluding——

Mr. Morrow: There is a chance of concluding the evidence this afternoon in a few minutes.

The Court: Let's do that.

Mr. Morrow: Very well, your Honor. We just have an office copy. I think it would be safer to read from the original. Do you have that, Mr. McManus? I am not certain this office copy——

Mr. McManus: I have it somewhere here.

Mr. Morrow: I will use my office copy, your Honor, and Mr. McManus may correct me if I am wrong. Reading from the copy, this is the answer of the president of the defendant to plaintiff's interrogatories under Rule 33 in this case. [78]

"State of Tennessee,  
County of Davidson—ss."

I might explain possibly to the jury that these interrogatories—questions were asked of the president of the defendant life insurance company by the plaintiff and I propose to read the questions and the answer which were made under oath on the plaintiff's demand.

The Court: It's part of it?

Mr. Morrow: Yes, your Honor.

The Court: Is that so stipulated?

Mr. McManus: So stipulated.

The Court: Very well. You may proceed.

Mr. Morrow: (Reading)

"I, Eldon Stevenson, Jr., the President of Defendant corporation, being first duly sworn, in an-

swer to plaintiff's Interrogatories to President of Defendant under Rule 33, depose and say:

"Interrogatory 1. State whether the defendant, The National Life and Accident Insurance Company ever had in its employ a person named G. D. Haws.

"Answer. Yes.

"Interrogatory 2. If the answer to interrogatory (1) is affirmative, state in what capacity he was employed, the dates of employment, his place of residence at the time of his employment, and his last address of [79] record as shown by the records of the defendant.

"Answer. He was employed by the company as an agent to solicit prospective applicants for insurance and to collect premiums from and service its policy holders. His employment began on April 27, 1953, and terminated November 15, 1954. His place of residence at the time of his employment was 6718 Loch Alene, Rivera, California.

"His last address of record as shown by the records of the defendant is: 525 North Ninth West, Orem, Utah.

"Interrogatory 3. Do the records of the defendant disclose which agent, employee or person obtained the application for life insurance policy #2081957 from George E. Gorey, and if so, what is the name and address of said agent, employee or person.

"Answer. Yes, G. D. Haws. His last address known to the defendant is 525 North Ninth West, Orem, Utah.

“Interrogatory 4. Do you know in whose handwriting or do the records of the defendant disclose in whose handwriting the answers to the questions on the application for life insurance policy #2081957 were made.

“Answer. I do not know in whose handwriting the answers to the questions in the application for said [80] policy were made and the records of the defendant do not disclose this information.

“Interrogatory 5. If the answer to the preceding interrogatory is affirmative in whose handwriting were the answers made, and are the answers in the handwriting of more than one person.

“Answer. I do not know whether or not the answers to said questions are in the handwriting of more than one person.

“Interrogatory 6. On April 30, 1954 what records, information and reports did the defendant have of and concerning the insured, George E. Gorey in addition to the application of George E. Gorey for life insurance, policy #2081957 and the report of the medical examiner, Dr. Suttan H. Groff, M.D.?

“Answer. None other than a report from the Retail Credit Company.

“Interrogatory 7. State whether or not there was any information whatever in the company's possession on April 30, 1954 concerning an illness or disease of George E. Gorey or concerning medical treatment or advice secured by George E. Gorey.

“Answer. There was no information in the company's possession on April 30, 1954 concerning an



illness or disease of George E. Gorey or concerning medical [81] treatment or advice secured by said George E. Gorey, excepting the information set forth in his application for said policy, in the medical examiner's report and in the report of the Retail Credit Company that he had never had an illness or disease, that he had not received any medical treatment or advice and that he had not undergone an electrocardiogram.

“Interrogatory 8. State whether or not there was any information whatever in the company's possession on or before November 18, 1955 concerning an illness or disease of George E. Gorey or concerning medical treatment or advice secured by said George E. Gorey.

“Answer. None other than that referred to and set forth in my answer to interrogatory 7.

“Interrogatory 9. State whether or not there is now in the possession of the defendant any record or information whatever which would indicate that any agent, employee or officer of the defendant or nor before November 18, 1955 may have known or may have had reason to believe George E. Gorey had consulted a doctor, had been ill or had any disease of any kind.

“Answer. There is no record or information in the possession of the defendant which indicates that any agent, employee or officer of the defendant on or before November 18, 1955 knew or had any reason to believe [81-A] that George E. Gorey had consulted a doctor, or that he had been ill or that he had any disease of any kind.

“Interrogatory 10. Do any records of the defendant disclose that George E. Gorey ever had a knee injury or leg injury

“(a) prior to April 30, 1954.

“(b) after April 30, 1954.

“Answer. No, they do not.

“Interrogatory 11. Do the records of the defendant disclose or show that any agent or employee of the defendant knew or had reason to believe George E. Gorey had ever consulted a doctor

“(a) prior to April 14, 1954.

“(b) prior to April 30, 1954.

“(c) prior to November 19, 1955.

“Answer. No, they do not.

“Interrogatory 12. Do the records of the defendant disclose the names of the persons who were present when the application for insurance policy #2081957 was made or executed.

“Answer. There are no records of the defendant disclosing the names of the persons who were present when the said application was made or executed other than George E. Gorey and G. D. Haws. [81-B]

“Interrogatory 13. Was the application for insurance signed in blank by Mr. Gorey, delivered to the defendant, and the answers later filled in by someone else?

“Answer. No, I have no knowledge which would indicate that any such procedure was followed.

“Interrogatory 14. Is there any information or records in the possession of the defendant which would indicate the application was signed after only a part of the questions had been answered, and that

the remaining questions were answered at a subsequent time.

“Answer. No.

“Interrogatory 15. State whether or not there is any information or records in the possession of the defendant which would indicate that any of the answers to the questions in the application were written on it by some employee or agent of the defendant in an office of the defendant after said application had been signed and delivered to defendant.

“Answer. No, there is no such information and there are no such records in the possession of the defendant.

“Dated this 19 day of June, 1956.

Signed “Eldon Stevenson, Jr.,” before “Margaret Welsh, Notary Public.” [81-C]

May I confer with Mr. Normandin just a moment, your Honor?

The Court: Yes. I want to inquire of you gentlemen with respect to the deposition of Mr. Miller, was it the testimony of Gwaltney that he had authority to reject the application?

Mr. Normandin: No, it was not, your Honor. His testimony was that if any information came——

The Court: He would have to refer it to the medical department?

Mr. Normandin: He would refer it to the medical director.

The Court: I overlooked that, in making a ruling, I reversed the ruling—if my recollection is correct here, Gwaltney’s testimony as I now recall it,

was he would merely make some notations on it and send it to the medical department.

Mr. Normandin: That's correct.

The Court: So Dr. Miller was the man who had the final say on it. Is that the record?

Mr. Normandin: That's the record, your Honor.

The Court: Miss Reporter, would you refer to your notes and again read the question—

Mr. Normandin: Shall I read it?

The Court: Yes.

Mr. Normandin: (Reading)

“By Mr. Robinson:

“Q. Suppose that that application had been [81-D] referred to you and it revealed that during October, 1953, the applicant had consulted a physician for a pain in his chest and a numbness and tingling of the left arm and hand, that said physician diagnosed the condition as coronary artery disease, a type of heart disease, and that the physician made an electrocardiogram of Mr. Gorey and confirmed his diagnosis, what would have been your action on the application?

“A. I would have rejected and declined the application.

“Q. Would the policy in suit have been issued by the Company?      “A. No.

“Q. Explain the basis of such rejection and declination.

“A. A diagnosis of coronary artery disease within one year prior to the date of the application would mean a material and substantial additional

risk for a life insurance company in issuing a policy on the life of that applicant. The existence of such a disease increases the risk of a premature death to such an extent that the applicant is rendered an uninsurable risk for life insurance by our company.”

Then follows the signature of Lloyd C. Miller, “Sworn to and subscribed before me,” Mr. Hix, the notary public.

Mr. Morrow: I believe that covers everything. If I might have a half minute?

The Court: Yes, you may. You may reopen. [81-E]

Mr. Morrow: So far as we can ascertain, that’s all the evidence the defendant has to offer.

The Court: The defendant rests?

Mr. Morrow: Yes, your Honor, that was, unless you——

The Court: I don’t say that under any and all circumstances you may reopen but that if you can do so without prejudice to the other side or counsel think of something overnight they overlooked, I always permit them to reopen. Do you anticipate any rebuttal?

Mr. McManus: I would like to call the plaintiff back.

The Court: Will it be very brief?

Mr. McManus: Quite brief, I believe.

The Court: Very well. You may call her now.

VERDA A. GOREY

recalled as a witness in her own behalf, having been previously duly sworn, testified further as follows:

Redirect Examination

Q. (By Mr. McManus): Mrs. Gorey, did your husband ever complain of any illness prior to his death?      A. Just pains in his chest.

Q. And how long before his death did he complain of pains in his chest?

A. About two or three months before.

Q. And would you explain just briefly to the jury what [82] type of carpenter work your husband did.

A. Well, he was, oh, what they call a framer, putting up the structure of the house and mainly what he did at one time he was roofer but just prior to his death that's what he was doing.

Q. And, Mrs. Gorey, do you know whether or not your husband ever took any nitroglycerin tablets preceding his death?      A. No, I do not.

Q. Did he take any sort of medicine before his death?

A. Yes, he took some headache pills. At one time he offered me one for my headache. That's why I happen to know that's what they were.

The Court: Did you take it?

The Witness: Yes.

Q. (By Mr. McManus): Did he ever tell you that he had any nitroglycerin tablets in the house or any other place?      A. No, he didn't.

Q. And Mrs. Gorey, when were you first aware

(Testimony of Verda A. Gorey.)

that your husband may have had heart trouble?

A. At the time of his death.

Mr. McManus: I believe that will be all.

Mr. Morrow: No questions, your Honor.

The Court: You may step down.

Mr. McManus: Plaintiff will rest, your Honor.

\* \* \* \* \*

November 14, 1956; 10:20 o'clock a.m.

The Court: Number 19691, Gorey against National Life case, stipulated, gentlemen, that the jury are absent?

Mr. McManus: So stipulated.

Mr. Morrow: Yes, your Honor.

The Court: Gentlemen, have you had an opportunity to go over these proposed instructions?

Mr. Morrow: Yes, we have gone over them, your Honor.

The Court: First we should take up the matter of your motion.

Mr. Morrow: We feel it might be more logical.

The Court: Yes, we might not have to discuss these instructions.

Mr. Morrow: Shall I proceed, your Honor?

The Court: Yes, if you will.

Mr. Morrow: If the Court please, the defendant moves the Court to direct a verdict under Rule 50, F.R.C.P. on all of the evidence in this case on the ground that there is not only no substantial conflict in the evidence but we believe there is no conflict in the evidence of a showing of misrepresentation and

concealment by the assured of material matters. We feel it follow as a matter of law that the plaintiff cannot recover. Specifically, the evidence introduced, the following evidence is not contradicted. First, [89] that the assured signed and delivered to the defendant company the application for insurance dated April 14, 1954. There is no conflict whatsoever in that. Secondly, that the application shows that the assured made false answers to at least two questions, namely, one, whether he had ever had an ailment or disease of the heart, and secondly, if he had ever consulted any physician. I know I don't need to go over the evidence on that. It seems to us to be very clear that there is absolutely no conflict on those matters.

The Court: Let's take one, take the question where he is asked whether he has consulted a physician.

Mr. Morrow: Shall I proceed on it?

The Court: The answer is "No."

Mr. Morrow: Yes, sir, never consulted any physician.

The Court: Assuming that that was his answer and that he knew it was false, or, put it another way, he made an understatement, doesn't there still remain the problem of whether or not the defendant relied on it whether or not the defendant would have issued the policy notwithstanding?

Mr. Morrow: Assuming your Honor is right on that point, the evidence on these matters we feel are—is entirely uncontradicted, overwhelmingly to the effect—that is the law when there is no evidence



that he answered otherwise than "No" to the question on consulting a doctor, and, of course, we realize that the law is if it involves a matter of slight [90] indisposition like a cold or sore toe or something, certainly no court is going to vitiate a policy on that ground. They shouldn't. But when it comes to a material matter——

The Court: We are dealing with whether or not there are any questions for the jury here. The insured is not here. He hasn't been heard from. The agent who wrote the answers hasn't been heard from.

Mr. Morrow: No.

The Court: Now, take that question about consulting a physician here. The jury might decide it isn't the insured's answers.

Mr. Morrow: I don't see how they could, your Honor. I believe the law is very clear that unless some evidence is shown, at least some inference from some acts to be drawn that the man couldn't read or that he didn't sign the policy, why——

The Court: The evidence is here he didn't write those answers.

Mr. Morrow: That's right. The evidence is here that he signed it and he stated he read it.

The Court: Yes, but that under what circumstances? After all, we are dealing now with what inference reasonably may be drawn.

Mr. Morrow: Yes.

The Court: The jury might well draw the inference, [91] might it not, that here this agent was so anxious to sell this policy, while we speak of con-

tracts of insurance, people entering into contracts of insurance, the truth is that the contracts of insurance if sold, the policies are sold, they are not bargain contracts in the sense you use when you speak of contracts. Here is an application that the agent who hasn't been produced wrote the answers. Now the man who gave the answers presumably nor the man who wrote them down has been here. Now, the jury might decide, might draw an inference that this insured wouldn't make an answer such as that to questions such as that about whether he consulted—the question, as I recall, is whether he ever consulted a physician. That means, that's broad enough in the 30 years of his life or 31, had he ever consulted a physician.

Mr. Morrow: That's right.

The Court: That's a very broad question. The jury might well believe in the first place this man was honest. The doctor appearing to testify for the defendant testified without objection this man was a very honest man.

Mr. Morrow: I remember that. I might say that I considered moving to strike that evidence here entirely in retrospect.

The Court: Even without that the jury might draw an inference from all the circumstances that certainly here was a question that no one, certainly very few people, very [92] few people in the United States at the age of 31 could answer "No." I just wonder how many people who can say at the age of 31 that they had never consulted a physician.

Mr. Morrow: I think your Honor is right about

some remote consultation or even a recent consultation, for instance, for a cold. I know I have studied the law on that phase of the matter and I know the cases holding if you have a cold, why, it's presumed the man might forget that. But here we have first of all a very important thing, coronary arteriosclerosis, coronary insufficiency.

The Court: You are talking language that the jury might well believe that this man who is a builder and carpenter didn't know the meaning of.

Mr. Morrow: However, the testimony the doctor gave is he told him he had heart disease.

The Court: That's a matter of opinion, yes.

Mr. Morrow: Further, your Honor, the evidence shows that he visited Dr. Kerchner on April 7, I think it was, 1954, which was approximately a week before he signed this application. It's true he visited him for a sore knee but he did not disclose that and furthermore, he must have had it right fresh in his mind the week before.

The Court: Yes. Supposing the jury decides just exactly that. Then may they not also decide here is an experienced insurance company who see these applications day after day [93] and he was an inexperienced man 31 years of age. The question whether or not he ever in his life had he consulted a physician and he says "None", might not the jury reasonably decide that the insurance company must have known that was probably not true but they relied not upon what he said, relied upon their own medical examiner?

Mr. Morrow: Your Honor, I believe——

The Court: Would they have issued the policy even if they had known the fact?

Mr. Morrow: I don't believe — pardon, your Honor.

The Court: Let's get one thing straight, first. If the company would have issued the policy notwithstanding if the company had known what the insured knew, it's immaterial, isn't it, whether he misrepresented to them or not?

Mr. Morrow: It might be.

The Court: If the company was so anxious to sell insurance that they winked at medical evidence before them, might not the jury decide there was no reliance upon these misrepresentations, or here they might decide it to be, with respect to consultation of physicians, an obvious concealment?

Mr. Morrow: I don't believe so, your Honor. I think the law is in substance, in answer to a direct question, to give it the importance at least which this certainly has. The company is entitled as a matter of law to rely on that.

The Court: Entitled to, but the question is, did it? [94]

Mr. Morrow: Yes, it's stipulated.

The Court: Can you, in your own experience, can you imagine looking at that and reading it and knowing what it means, without reason to question as to whether or not that's true with respect to a man 31 years of age?

Mr. Morrow: Well, I say, your Honor, again that it seems to me that that's a very important matter and he is bound by it. He read it.

The Court: It's a jury question. Isn't it?

Mr. Morrow: I don't think so because the evidence—I don't think the jury would be able to, they might do so, but I don't think the jury is entitled to draw an inference from those facts.

The Court: Would it be beyond the bounds of reason?

Mr. Morrow: Yes, I think so, in the state of the evidence. I think the Court, if a verdict be returned, it would have to set aside the verdict as a matter of law. There is no, just no evidence to the contrary. It can draw an inference but you have got to draw some reasonable inference, it seems to me, unless the line of reasoning goes beyond reasonable inference.

The Court: It's a matter of common knowledge, isn't it, that insurance companies sometimes issue a policy and boost the premiums in the face of admitted medical reasons?

Mr. Morrow: Yes, that's true, I know of a [95] few instances. I have heard of instances where they may take a man over and charge him three times the premium in the light of their own medical examination, the company says, "We won't issue it on a preferred risk, ordinary rate, we will issue it to you at three times the rate," but the evidence shows this is an ordinary rate and contract.

The Court: But in all of these cases, isn't it open to the jury to believe whether or not the company relied——

Mr. Morrow: Stipulated, your Honor, that right's in the stipulation, that the company relied on the

application and the medical report, stipulated by counsel.

The Court: Yes. That isn't the correct—my question, properly phrased, is whether the company would have——

Mr. Morrow: Would have issued——

The Court: ——issued but for it and if the company had known what the insured knew, I take it that if the evidence shows that the doctor asked the insured if he had ever had some Latin phrase that long and the insured said "No" and it later developed that he had had it not only once but a half a dozen times but that he didn't know what the language meant, I take it that that would have not been a misrepresentation?

Mr. Morrow: I think if I were sitting as a Judge and were to decide that question, I would decide it that way.

The Court: Don't we have two factors here? One, to determine what the insured knew, what he [96] understood, and two, what the company would have known—would have done if the company had known as it was entitled to know the facts at least as the insured understood them. They were entitled to good faith answers to the questions according to the understanding of the insured.

Mr. Morrow: Yes. Take——

The Court: Isn't the question then what would they have done with respect to the issuance or non-issuance of the policy if they had known the things that the insured knew or understood?

Mr. Morrow: Or if they had known what he had, had heart disease or coronary arteriosclerosis, if they had known he had consulted a doctor?

The Court: Suppose he did and didn't know it?

Mr. Morrow: He certainly knew he consulted a doctor.

The Court: Many people have been told they had heart disease and they have lived out and have made mockery of the doctor who said it. If he had been told, he understood it was the doctor's opinion that he had heart disease, then the insurance company was entitled to know that.

Mr. Morrow: Certainly.

The Court: If it asked the question which elicited that information.

Mr. Morrow: It did.

The Court: If it showed interest in having [97] that information——

Mr. Morrow: And it did.

The Court: Then doesn't the question—even if you decide that he misrepresented in the sense that he concealed, then doesn't the question still remain, would the company have issued the policy had it known what the plaintiff concealed?

Mr. Morrow: I am not entirely convinced from my study of the law, that is so, but assuming for argument that your Honor is right on that score, I say that the uncontradicted evidence is that the company would not have issued the policy. Now, we have the testimony of the underwriting—senior underwriter and of the chief of the medical depart-

ment and this question, your Honor no doubt recalls, we expressly put to them and they answered they would not have issued this policy.

The Court: That type of thing, that always presents a problem of fact finding in fraud cases, "Would you have entered into the transaction?" "Did you rely?" "Yes, I relied." "Would you have entered into the transaction but for the recommendation?" "No, I would not." You aren't suggesting, because there is no one to take the witness stand to say "Yes," he would have, that the fact finder must find—it isn't like that type of thing, "Where were you on the night of June 12th?" It involves the mental state. It seems to me it's always a problem for the fact finder to state that person is telling the truth when he said what he would have done.

Mr. Morrow: Isn't the law on that subject that unless there is some impeachment of the witness that the testimony of a single witness is entitled to belief or some such wording as the cases say?

The Court: Yes, of course, if that were all in the case, but that's never all that's in the case. That's surrounding circumstances in the case in a fraud case, surrounding circumstances of what kind of a deal was it and all the circumstances surrounding the transaction, perhaps to raise inferences that are reasonable or contrary to this certain fact that the plaintiff would not have entered into the transaction but for reliance. The same way here. Here you have the report of the doctor, the company's chosen medical man. Now, the jury might well find,



assuming a person is correct, wouldn't the company rely upon its own medical man to know as much as Dr. Kerchner found out in this matter?

Mr. Morrow: I think there is a lot to the effect, if your Honor is interested, to the effect that an insurance company has this medical doctor examine the insured before issuing the policy is of no moment.

The Court: It must be of some moment. It may not be controlling, no. The company isn't forced to rely upon that factor alone. The beneficiary cannot come in and effectively say, "Well, you had him examined and you found out yourself." The company is entitled to rely upon those answers to [99] the medical history given by the insured.

Mr. Morrow: Another thing, I think the evidence, so far as you are talking about the medical examiner, the evidence would seem to indicate from the report, that the assured never gave the examiner any of his history. You can see in this type of disease, as Dr. Kerchner stated, you got to take your EKG, your electrocardiogram. You have got to have the man exercise to find nothing wrong with him before he exercised.

The Court: How do we know whether this man even knew what an electrocardiogram was?

Mr. Morrow: Well, he had one taken of him.

The Court: He still might not know what they were doing, what it was. Of course, people who have have it. It isn't an every day word. Supposing—have you ever had a myelogram?

Mr. Morrow: I don't recall it.

The Court: A man says to himself, "I never heard of that one. I am sure I never had the thing." The district manager says that these applicants for insurance are asked to check over these answers and be sure they are correct before they sign. For instance, they usually have asked me about members of my family, what they died of and I tell them what I understand. Would that vitiate the policy if I didn't know what I was talking about, if I said it was angina pectoris and the death certificate showed it was cirrhosis of the [100] liver, would that vitiate the policy?

Mr. Morrow: I doubt it very much.

The Court: They are entitled to rely upon it. It's misrepresentation. Isn't it all that you can expect under the circumstances, is the good faith understanding of the insured as to his medical history?

Mr. Morrow: You mentioned the members of the family business. I think that would come under a different category. All the company can ask for is that the applicant gives his best knowledge of it. He may be wrong but—

The Court: Suppose they asked the man if he ever had an electrocardiogram and he says "No." He thought what was an electrocardiogram was a metabolism test. Wouldn't the situation be the same?

Mr. Morrow: I think it must be presumed that he knew what he was talking about. He was asked the question and it seems to me that where he has had one within the last year—

The Court: I am not suggesting, Mr. Morrow, that these answers are clear. All I am suggesting is that these are inferences which the jury are called upon to draw on the surrounding circumstances and surrounding circumstances do not give them the best evidence. It seems to me they are particularly entitled to draw inferences when as in this case where we don't have the testimony of the assured, we don't have even the agent. There is no explanation here why he wasn't [101] produced, is there? He lives in Utah?

Mr. Morrow: He is in Utah, the evidence shows. I don't think it's incumbent upon the defendant to call the agent no longer in its employ, as the evidence shows. Out of state, you usually take his deposition. It seems to us that if there is to be any point made by the plaintiff that the assured did not understand any of these matters that it's up to the plaintiff to present some evidence to that effect. It's not up to the defendant.

The Court: Well, the jury might so infer. But isn't it a problem for them to draw reasonable inferences one way or the other in the situation?

Mr. Morrow: Yes, that's the rule, but I certainly disagree with your Honor that, if not that all of them, at least that some of them may be arguable. He, however, consulted a doctor, the evidence shows, in October '53, because he had three consultations in regard to his heart. They asked the specific question on the application, "Have you ever had a heart disease or ailment of the heart?" The evidence shows without contradiction this man, within one

week prior to the time he signed his application, he consulted with this very same doctor, and the month before he had consulted with him, true, about different things, but how can you possibly draw an inference that he knew and he deliberately was failing to answer a direct question on that point? I agree with you [102] if it had been three years or ten years before or some minor thing, I think the state of the law should say it doesn't make any difference because it's not material and consequently I think a jury might well infer that he didn't have it in his mind and therefore he is not misleading the company on any material matter. We got something so fresh, it must have been fresh in his mind. It calls for an answer, "Yes, I have," and give the particulars that the application says, "Give the particulars," and he answers "None." Now, he might have had a loss of memory or something to be polite about it, but this defendant isn't charged with that. It's the man's obligation. Just take that one thing. You can argue all you want about heart disease and other matters, how can you infer on that one thing, it's a very important thing, that the jury would be entitled to draw an inference that he did not know what he was being asked or any other inference.

The Court: Let's assume they would. Wouldn't they be entitled to draw an inference you must have known that that answer was probably not true, not correct, and the company nonetheless just relied upon its own medical report and issued the policy?

Mr. Morrow: And I think as a matter of law the company is absolutely entitled to rely on it.

The Court: The question is, did they? Isn't that a question for the jury, did they rely to the [103] extent that they would never have issued the policy but for that?

Mr. Morrow: That's uncontradicted evidence, uncontradicted evidence all the way down the line. It's so important. It's not an unimportant question, your Honor.

The Court: No, it's a very important thing. It involves the state of mind. It is in my view always a question for the jury as fact finder.

Mr. Morrow: I think he is presumed to have had that in mind, at least anything as recent——

The Court: Let us assume the jury finds that was a flagrant misrepresentation. Might not the jury also find anyone would know that probably wasn't true and this company, experienced in handling these matters day after day, must have known it wasn't true? They raised no question about it and they went ahead and issued the policy notwithstanding. They couldn't rely upon it to the extent that it influenced them in issuing the policy.

Mr. Morrow: I disagree with your Honor on that because I think the law is very clear that it's a matter of law on a matter like, not have been up to the jury to consider. I think it's a matter of law and it has been ruled on in many cases in similar matters.

The Court: I will deny the motion at this time.

You may renew it after the verdict if you find it necessary. \* \* \* \* \* [104]

Thursday, Nov. 15, 1956, 9:30 A.M.

\* \* \* \* \*

The Court: You have heard the evidence and the argument, ladies and gentlemen of the jury.

Now, it is the duty of the court to instruct you as to the law governing the case. It is your duty, as jurors, to follow the law as stated in the instructions of the Court and to apply the law so given to the facts as you find them from the evidence before you. You are not to single out one instruction alone as stating the law, but must consider the [12] instructions as a whole.

Regardless of any opinion you may have as to what the law ought to be, it would be a violation of your sworn duty to base a verdict upon any other view of the law than that given in the instructions of the court.

You have been chosen and sworn as jurors in this case to try the issues of fact presented by the allegations of the complaint of the plaintiff, Verda A. Gorey, and the answer thereto of the defendant, The National Life and Accident Insurance Company. You are to perform this duty without bias or prejudice as to any party. The law does not permit jurors to be governed by sympathy, prejudice, or public opinion. The parties and the public expect that you will carefully and impartially consider all the evidence, follow the law as stated by the court, and reach a just verdict, regardless of the consequences.

This case should be considered and decided by

you as an action between persons of equal standing in the community, of equal worth, and holding the same or similar stations in life. A corporation is entitled to the same fair trial at your hands as a private individual. The law is no respecter of persons; all persons, including corporations, stand equal before the law, and are to be dealt with as equals in a court of justice.

The burden is on the plaintiff in a civil action, such [13] as this, to prove every essential element of plaintiff's case by a preponderance of the evidence. If the proof fails to establish any essential element of plaintiff's case by a preponderance of the evidence, then you must find for the defendant.

The term "preponderance of the evidence" means the greater weight of the evidence. In other words, such evidence as, when weighed with that opposed to it, has more convincing force and produces in your minds conviction of the greater probability of truth, after you have considered all the evidence in the case.

Evidence may be either direct or indirect. Direct evidence is that which in itself, if true, conclusively establishes a fact. Indirect evidence is that which tends to establish a fact in dispute by proving another fact. Indirect evidence is of two kinds, namely, presumptions and inferences.

An inference is a deduction or conclusion which reason and common sense lead the jury to draw from facts which have been proved.

A presumption is an inference which the law requires the jury to make from particular facts.

Unless declared by law to be conclusive, a presumption may be overcome or outweighed by direct or indirect evidence to the contrary of the fact presumed; but unless so outweighed, the jury are bound to find in accordance with the presumption. [14]

Unless and until outweighed by evidence to the contrary, the law presumes that a person is innocent of crime or wrong; that official duty has been regularly performed; that private transactions have been fair and regular; that the ordinary course of business has been followed; that things have happened according to the ordinary course of nature and the ordinary habits of life; and that the law has been obeyed.

Statements and arguments of counsel are not evidence in the case, unless made as an admission or stipulation of fact. When the attorneys on both sides stipulate or agree as to the existence of a fact, the jury must accept the stipulation as evidence and regard that fact as conclusively proved.

The evidence in the case consists of the sworn testimony of the witnesses, all exhibits which have been received in evidence, all facts which have been admitted or stipulated, and all applicable presumptions stated in these instructions. Any evidence as to which an objection was sustained by the court, and any evidence ordered stricken by the court, must be entirely disregarded.

You are to consider only the evidence in the case. But in your consideration of the evidence you are not limited to the bald statements of the witnesses. On the contrary, you are permitted to draw, from



facts which you find have been proved, such inferences as seem justified in the light of [15] your experience.

You, as jurors, are the sole judges of the credibility of the witnesses and the weight their testimony deserves. A witness is presumed to speak the truth. But this presumption may be outweighed by the manner in which the witness testified, by the character of the testimony given, or by contradictory evidence. You should carefully scrutinize the testimony given, the circumstances under which each witness has testified, and every matter in evidence which tends to indicate whether the witness is worthy of belief. Consider each witness's intelligence, motive and state of mind, and demeanor and manner while on the stand. Consider also any relation each witness may bear to either side of the case; the manner in which each witness might be affected by the verdict; and the extent to which, if at all, each witness is either supported or contradicted by other evidence.

Inconsistencies or discrepancies in the testimony of a witness, or between the testimony of different witnesses, may or may not cause the jury to discredit such testimony. Two or more persons witnessing an incident or a transaction may see or hear it differently; and innocent misrecollection, like failure of recollection, is not an uncommon experience. In weighing the effect of a discrepancy, consider whether it pertains to a matter of importance or an unimportant detail, and whether the discrepancy results from innocent error or [16]

willful falsehood. If you find the presumption of truthfulness to be outweighed as to any witness, you will give the testimony of that witness such credibility, if any, as you may think it deserves.

The rules of evidence ordinarily do not permit a witness to testify as to his opinions or conclusions. A so-called expert witness is an exception to this rule. A witness who by education and experience has become expert in any art, science, profession or calling may be permitted to state his opinion as to a matter in which he is versed and which is material to the case, and may also state the reasons for such opinion. You should consider each expert opinion received in evidence in this case and give it such weight as you think it deserves; and you may reject it entirely if you conclude the reasons given in support of the opinion are unsound.

During the trial of this case certain testimony has been read to you by way of deposition. The testimony of a witness who for some reason cannot be present to testify from the witness stand is usually presented in the form of a deposition. Such testimony is entitled to the same consideration and, in so far as possible, is to be judged as to credibility and weighed by the jury in the same way as if the witness had been present.

The defendant, The National Life and Accident Insurance Company, is a corporation, and as such can act only through [17] its officers and employees, who are its agents. The acts and omissions of an agent, done within the scope of his authority, are

in contemplation of law the acts and omissions respectively of a corporation whose agent he is.

A witness may be discredited or impeached by contradictory evidence; or by evidence that at other times the witness has made statements which are inconsistent with the witness' present testimony.

If you believe any witness has been impeached and thus discredited, it is your exclusive province to give the testimony of that witness such credibility, if any, as you may think it deserves.

If a witness is shown knowingly to have testified falsely concerning any material matter, you have a right to distrust such witness' testimony in other particulars; and you may reject all the testimony of that witness or give it such credibility as you may think it deserves.

While the burden rests upon the party who asserts the affirmative of an issue to prove his allegation by a preponderance of the evidence, this rule does not require demonstration, or such degree of proof as produces absolute certainty; because such proof is rarely possible.

In a civil action such as this, it is proper to find that a party has succeeded in carrying the burden of proof on an issue of fact if, after considering all the evidence [18] in the case, the evidence favoring such party's side of the question is more convincing than that tending to support the contrary side, and if it causes the jurors to believe that the probability of truth on such issue favors that party.

You are not bound to decide any issue of fact in accordance with the testimony of any number of

witnesses which does not produce conviction in your minds, as against the testimony of a lesser number of witnesses or other evidence which does produce conviction in your minds.

The test is not which side brings the greater number of witnesses, or presents the greater quantity of evidence, but which witness and which evidence appeals to your minds as being most accurate and most trustworthy.

The testimony of a single witness, which produces conviction in your minds, is sufficient for the proof of any fact, and would justify a verdict in accordance with such testimony even though a number of witnesses may have testified to the contrary if, after weighing all the evidence in the case, you believe that the balance of probability points to the accuracy and honesty of the one witness.

The burden is upon the plaintiff in this case to prove by a preponderance of the evidence that at the time of death of George E. Gorey the life insurance policy involved in this case was in full force and effect and all premiums paid up to that date.

To establish the defense of avoiding that policy of life insurance on the ground of misstatement or concealment by George E. Gorey of material facts, the burden is upon the defendant to prove by a preponderance of the evidence that some material misstatement was made by George E. Gorey, or that said George E. Gorey concealed some material fact from the defendant, and that the defendant would never have issued the policy but for such concealment or misstatement.

An insurance company has the unquestioned right to determine for itself what risks it will accept, to select those whom it will insure, and to rely upon an applicant for insurance of such information as it desires as a basis for its determination so that it may exercise a wise discrimination in selecting its risks. The defendant company was therefore entitled to know the truth as to the facts relative to George E. Gorey's physical condition and medical history insofar as it made inquiry of him at the time he applied for the insurance policy involved in this action and insofar as such facts were then known to and understood by George E. Gorey himself.

It is the duty of each party to a contract of insurance to communicate to the other, in good faith, all facts within his knowledge which are or which he believes material to the contract, and which the other party has not the means of ascertaining. [20]

Answers to questions in an application for insurance are generally deemed material representations of fact, which, if false, may vitiate the policy.

If an insurance company is misled by misstatements or concealments of an insured person into issuing a policy it would not otherwise have issued, the company is not liable on the policy, regardless of whether the failure of the insured person to state the true facts as known and understood by him was intentional or unintentional.

The representations of George E. Gorey in his application for insurance in question here were material, if they were such as to mislead the defendant

into issuing a policy which the defendant would not otherwise have issued.

The defendant alleges that George E. Gorey made certain false representations to the defendant company in his application for the insurance policy, in that he did conceal by failing to disclose in said application a certain ailment or disease, namely, an ailment or disease of the heart, for which he had consulted a physician. The defendant further contends that George E. Gorey concealed, by failing to disclose in his application, that he had ever consulted a physician before the date of the making of the application on April 14, 1954.

A concealment is a neglect to communicate that which a party knows and ought to communicate.

If you find from a preponderance of the evidence that George E. Gorey had knowledge of such facts but concealed them from the defendant, as the defendant alleges, and further find that the defendant would never have issued the policy if the defendant had known and understood whatever George E. Gorey may have known and understood with respect to such matters at the time of the issuance of the policy, then your verdict should be in favor of the defendant.

The defendant also *defense* this action upon the ground that, in his written application for the issuance by the defendant of the insurance policy involved in this action, George E. Gorey agreed with the defendant that the proposed insurance policy would not be effective unless the policy was delivered to and accepted by him during his lifetime and

good health, and the policy issued to him so provided.

The term "good health" contained in the application and the insurance policy does not mean perfect health, but does mean an ordinary and reasonable degree of health.

If you find that George E. Gorey was not in good health at the time the insurance policy was delivered to and accepted by him, and if you further find that George E. Gorey had knowledge that he was not in good health at such time and that the defendant had no knowledge thereof at such time, and that the defendant would never have issued the policy if the defendant had known and understood whatever George E. [22] Gorey may then have known and understood with respect to the state of his health, then the insurance policy did not become effective upon delivery to George E. Gorey or thereafter, and your verdict should be for the defendant.

If you find from the evidence that the insured, George E. Gorey, was not in good health at the time he made his application for insurance but did not know it, the representation by said insured that he was in good health will not void the policy.

The parties to this action have stipulated or agreed that the principal amount involved in the life insurance policy in question is \$8,824 and that interest on that amount at the rate of seven per cent per annum from the death of George E. Gorey until this date amounts to \$607, a total sum of \$9,431. Accordingly, the amount of your verdict

should be for the sum of \$9,431 in the event you find in favor of the plaintiff.

The law of the United States permits the judge to comment to the jury on the evidence in the case. Such comments are only expressions of the judge's opinion as to the facts; and the jury may disregard them entirely, since the jurors are the sole judges of the facts.

During the course of a trial, I occasionally ask questions of a witness, in order to bring out facts not then fully covered in the testimony. Do not assume that I hold [23] any opinion on the matters to which my questions related. Remember at all times that you, as jurors, are at liberty to disregard all comments of the court in arriving at your own findings as to the facts.

It is the duty of attorneys on each side of a case to object when the other side offers testimony or other evidence which counsel believes is not properly admissible. It is the duty of the court to decide whether, under the rules of evidence, such testimony or other evidence may be received.

Whenever the court has sustained an objection to an offer of evidence, the jury are not to consider in their deliberations the offer or the objection, or the ruling of the court in rejecting the offered evidence.

Thus when the court has sustained an objection to a question, the jury are to disregard the question, and may draw no inference from the wording of it or speculate as to what the witness would have said if permitted to answer. Nor may the jury as-



sume an attorney has objected to a question because he expected the answer, if given, would be unfavorable to his side of the case.

In allowing evidence to be introduced over the objection of counsel, the court does not, unless expressly stated, indicate any opinion as to the weight or effect of such evidence. As stated before, the jurors are the sole judges of the credibility of all witnesses and the weight and effect of all evidence.

The verdict must represent the considered judgment of each juror. In order to return a verdict, it is necessary that each juror agree thereto. Your verdict must be unanimous.

It is your duty, as jurors, to consult with one another and to deliberate with a view to reaching an agreement, if you can do so without violence to individual judgment. Each of you must decide the case for yourself, but do so only after an impartial consideration of the evidence with your fellow jurors. In the course of your deliberations, do not hesitate to re-examine your own views and change your mind if convinced it is erroneous. But do not surrender your honest conviction as to the weight or effect of evidence solely because of the opinion of your fellow jurors, or for the mere purpose of returning a verdict.

You are not partisans. You are judge—judges of the facts. Your sole interest is to ascertain the truth from the evidence in the case.

Upon retiring to the jury room, you will select one of your number to act as foreman. The fore-

man will preside over your deliberations and will be your spokesman in court.

Forms of verdict have been prepared for your convenience. I will exhibit them to you. They are both entitled in the court and cause and the first one reads,

“We, the jury in the above-entitled cause, find in favor of the plaintiff, Verda A. Gorey, and against the defendant, The National Life and Accident Insurance Company, for the sum of \* \* \*” blank dollars. And then, “Los Angeles, California.” And then “November” blank “1956.” And then a line for signature over the words “Foreman of the jury.”

The other form provides, entitled in the court and cause,

“We, the jury in the above-entitled cause, find in favor of the defendant, The National Life and Accident Insurance Company, and against the plaintiff, Verda A. Gorey, for the sum of \* \* \*” blank dollars. And then “Los Angeles, California. November” blank “1956.” And then a line for signature over the words “Foreman of the Jury.”

You will take these forms to the jury room and when you have reached unanimous agreement as to your verdict, you will have your foreman complete the form. If your verdict be unanimous in favor of the plaintiff, you will have your foreman write in the amount thereof and complete the date and sign that form of verdict as foreman of the jury.

If you are in unanimous agreement and your verdict is in favor of the defendant, you would use

the other form and have the foreman complete the date and sign as foreman of the jury. You will then return with your verdict to the courtroom.

If it becomes necessary during your deliberations to communicate with the court, you may send a note by the bailiff. Never attempt to communicate with the court by sending an oral message by the bailiff. Always send a written message. The court will reply in writing or summon you back into court and reply to you in open court, but never through oral communication. Never give or accept an oral communication from the court unless it be with respect to continuing your deliberations or going to lunch or to dinner, or some such matter of your convenience — but nothing concerning the case.

And bear in mind you are not to reveal to the court or to any person how the jury stands, numerically or otherwise, until you have reached a unanimous verdict. [27]

\* \* \* \* \*

The Court: Has the plaintiff any objections or exceptions to make with respect to the instructions given or refused?

Mr. McManas: The plaintiff is not going to make any objections or exceptions to the instructions.

The Court: Is the defendant?

Mr. Morrow: Yes, your Honor, the defendant has for the record.

If the court please, I have some notes on these matters, which I trust are reliable. There are a few

that have been interchanged, and if I stumble around on a few of them I trust your Honor will bear with me for a moment.

I might say, since I don't have this in my notes, I notice your Honor did apparently not give No. 20.

The Court: I haven't given it yet. I wait to give that until last. I take it you have no objection.

Mr. Morrow: No, no, your Honor. I wasn't certain what the situation was. We are not objecting to that. As a matter of fact, we want it.

Now, taking the objections up in order—the clerk just handed me an instruction entitled 12-A.

The Court: I had my secretary rewrite it to make the changes you requested this morning on Instruction 12-A to strike the phrase “may return the premiums and cancel,” and insert instead, “is not liable on the policy.”

Mr. Morrow: Yes, your Honor. I am trying to find my notes here. I think I will save time by using it.

Shall I proceed, your Honor?

The Court: Oh, yes.

Mr. Morrow: The first one the defendant objects to is No. 6-A relating to expert witnesses. Your Honor, briefly for the record, we object to the giving of the entire instruction on the ground that there was only one witness called in this case which might possibly be considered to be an expert; and we believe, however, that he was not called as an expert. He was only asked to give testimony relative to what actually occurred, not as an expert. And, therefore, we feel that the instruction is in-

correct as applied to the circumstances of this case, and that the wording, in particular "and you may reject entirely if you conclude the reasons given in support of the opinion are unsound \* \* \*" We believe might well confuse the jury with respect to Dr. Kerchner's testimony; he being a major witness for the defendant.

No. 11—pardon me just a moment, your Honor—line 17, the defendant objects to the clause reading "\* \* \* and that the defendant would never have issued the policy but for such concealment and misstatement \* \* \*" as against the law, and we have heretofore suggested to the court and the proper substitute clause for that would read as follows: "and that defendant was induced to issue the policy by reason of any such material misstatement or concealment."

No. 12, your Honor, line 17, the defendant objects to the inclusion of the words "and understood by," which referred to George E. Gorey as not being required by law and being improper under the law; namely, that if the instruction is given if such facts were known to him that it is improper to add the further words "and understood by."

The reason for my hesitation, your Honor, is that I am examining the new instruction 12-A which the clerk has just handed me.

The Court: It is the one I read to the jury.

Mr. Morrow: Yes. That instruction, your Honor, 12-A, line 12, the words "generally deemed," referring to material representations, we object to in—

we object to that as against the law, in that the only representations or concealments involved in this case are material representations and concealments, as a matter of law, under the authorities in cases. Therefore, the jury might well be misled in that connection.

In line 13, the defendant objects to the word "may," referring to "vitate the policy." Under the law the defendant contends that the word should be "will" and not "may."

Lines 23 to 25, the defendant objects to those, that clause, reading "If they were such as to mislead the defendant into issuing a policy which the defendant would not have otherwise have issued" as being contrary to the law applicable.

And, instruction No. 13, the defendant objects to the clause commencing on line 21 and ending on line 24, reading as follows:

"\* \* \* would never have issued the policy if the defendant had knowledge of whatever George E. Gorey may have known and understood with respect to such matters at the time of the issuance of the policy,"

as being contrary to the law applicable.

The Court: Is that the way it reads?

Mr. Morrow: That is the way I have got it. It is conceivable that we may have——

The Court: If defendant had known and understood whatever George E. Gorey may have known and understood,—isn't that the way it reads. Let me look at the original.

Yes, that is the way it was given.

“And further find that the defendant would never have issued the policy if the defendant had known and understood whatever George E. Gorey may have known and understood with respect to such matters at the time of the issuance of the policy, your verdict should be in favor of the defendant.”

Mr. Morrow: It may be, as I said, there were two or three switches of papers, that we got them switched. But I'll defer to your Honor's reading.

The Court: That's the way it was given.

Mr. Morrow: Then I will amend the objection to conform to your Honor's statement of that part of the instruction as given. Thank you.

Instruction No. 14, the line commencing—line 22, reading as follows:

“And that the defendant would never had issued the policy if the defendant had known and understood whatever George E. Gorey may then have known and understood with respect to the state of his health,”

we object to that as being an incorrect statement of the law applicable. [33]

If the court please, the defendant objects to the ruling of the court and the court not giving the defendant's requested instructions Nos. 3, 5, 8, 9, 10, 11, 12 and 13.

The Court: Upon the ground heretofore stated?

Mr. Morrow: Yes, on the ground heretofore stated, your Honor. And we believe in that connection that the instructions are proper statements of the law applicable and that the instructions should

have been given under the facts, or under the evidence received in this case.

That completes our statement, your Honor, at this time.

The Court: Very well. Will you summon the jury, Mr. Bailiff?

(Whereupon the jury re-entered the courtroom.)

(The following proceedings were had in the presence of the jury:)

The Court: Is it stipulated, gentlemen, that the jury are present?

Mr. McManas: So stipulated.

Mr. Morrow: So stipulated.

The Court: Mr. Ferguson, happily it hasn't been necessary to call upon you to continue further in the case. If you will remain after the jury have retired, I will instruct you further.

Before concluding the instructions, I think it is proper to caution you that nothing I have said in the instructions and nothing in any form of verdict which has been prepared for your convenience is to suggest or to convey to you in any way or manner any intimation as to what I think your verdict should be. What the verdict shall be is the sole and exclusive duty and responsibility of the jury, of course.

Mr. Clerk, will you swear the bailiffs?

The Clerk: Yes, your Honor.

(Whereupon the bailiffs were sworn.)

The Court: Ladies and gentlemen of the jury, you will be in the custody of the bailiffs who have



just been sworn. The instructions of the court, as read, have been filed and they will be sent with you to the jury room, along with the exhibits in the case.

\* \* \* \* \*

[Endorsed]: Filed February 15, 1957.

---

[Endorsed]: No. 15442. United States Court of Appeals for the Ninth Circuit. National Life and Accident Insurance Company, Appellant, vs. Verda A. Gorey, Appellee. Transcript of Record. Appeal from the United States District Court for the Southern District of California, Central Division.

Filed: February 18, 1957.

Docketed: February 18, 1957.

/s/ PAUL P. O'BRIEN,

Clerk of the United States Court of Appeals for  
the Ninth Circuit.

In the United States Court of Appeals  
for the Ninth Circuit

No. 15442

THE NATIONAL LIFE AND ACCIDENT IN-  
SURANCE COMPANY,                      Appellant,

vs.

VERDA M. GOREY,                                      Appellee.

APPELLANT'S STATEMENT OF POINTS  
ON WHICH APPELLANT INTENDS TO  
RELY ON APPEAL

The points upon which appellant, The National Life and Accident Insurance Company intends to rely on this appeal are as follows:

Point I. Appellant's defenses were each proved by uncontradicted evidence and the trial court erred in denying appellant's motion for a directed verdict. The trial court erred in denying appellant's motion for an order setting aside the verdict and for judgment under Federal Rules of Civil Procedure, Rule 50(b). Appellant is entitled to judgment.

Point II. The trial court committed prejudicial and reversible error in giving certain jury instruc-

tions and in refusing to give certain jury instructions requested by appellant.

Dated: February 25, 1957.

OVILA N. NORMANDIN and  
JOHN C. MORROW,

/s/ By JOHN C. MORROW,

Attorneys for Appellant, The National Life and  
Accident Insurance Company.

Affidavit of Service by Mail attached.

[Endorsed]: Filed February 27, 1957. Paul P.  
O'Brien, Clerk.



No. 15442.

IN THE

# United States Court of Appeals

FOR THE NINTH CIRCUIT

---

THE NATIONAL LIFE AND ACCIDENT INSURANCE COM-  
PANY,

*Appellant,*

*vs.*

VERDA A. GOREY,

*Appellee.*

---

Appeal From the United States District Court for the  
Southern District of California, Central Division.

---

## APPELLANT'S OPENING BRIEF.

---

OVILA N. NORMANDIN, and  
JOHN C. MORROW,

210 West Seventh Street,  
Los Angeles 14, California,

*Attorneys for Appellant, The National Life  
and Accident Insurance Company.*

FILED

MAY - 2 1957

PAUL F. M. BRYER, CLERK



## TOPICAL INDEX

	PAGE
Statement of pleadings and facts showing basis of jurisdiction of the United States District Court and of the United States Courts of Appeals.....	1
Statement of case and questions involved.....	2
Specification of errors relied upon.....	4
Argument .....	12
Point I. The trial court erred in denying appellant's motion for a directed verdict and for an order setting aside the verdict and for judgment under F. R. C. P., Rule 50(b). The evidence establishing appellant's defenses of misrepresentation and concealment was uncontradicted.....	12
1. Summary of applicable law on misrepresentation and concealment .....	12
2. The evidence proving appellant's defenses is uncontradicted .....	15
(a) The evidence is uncontradicted that George E. Gorey, the insured, represented in writing to appellant in his written application for the policy that he had never had an ailment or disease of the heart and that he had never consulted any physician.....	15
(b) The evidence is uncontradicted that said representations by the insured that he had never had an ailment or disease of the heart and that he had never consulted any physician were false and that the insured had knowledge thereof at the time of his application for the policy.....	17
(c) The evidence is uncontradicted that the insured misrepresented to and concealed from the insured's medical examiner and from the insurer the fact that he had undergone an electrocardiogram.....	21

(d) The evidence is uncontradicted that the insured concealed his medical history from the insured, that the insurer relied on the application and the medical examiner's report in issuing and delivering the policy, and that it had no knowledge of the misrepresentations or of the facts concealed by the insured .....	22
(e) The evidence is without conflict that the insured was not in good health when the policy was delivered to and accepted by the insured.....	25
3. Appellant's motions for a directed verdict and for judgment under Rule 50(b) should have been granted. The judgment and order denying the motions should be reversed and judgment for appellant directed.....	26
Point II. The trial court committed prejudicial and reversible error in giving the following jury instructions and in refusing to give the following jury instructions requested by appellant .....	31
1. The trial court erred in giving the jury instruction specified under Specifications of Errors, Specification No. (1), Point II.....	31
2. The trial court erred in giving the jury instructions specified under Specification of Errors, Specification No. (2), Point II.....	33
3. The trial court erred in giving the jury instruction specified under Specification of Errors, Specification No. (3), Point II.....	34
4. The trial court erred in giving the jury instruction specified under Specification of Errors, Specification No. (4), Point II.....	35
5. The trial court erred in refusing to give appellant's requested Instruction No. 3, specified under Specification of Errors, Specification No. (5), Point II.....	36



6. The trial court erred in refusing to give appellant's requested Instruction No. 5, specified under Specification of Errors, Specification No. (6), Point II.....	37
7. The trial court erred in refusing to give appellant's requested Instruction No. 8, specified under Specification of Errors, Specification No. (7), Point II.....	37
8. The trial court erred in refusing to give appellant's requested Instruction No. 9, specified under Specification of Errors, Specification No. (8), Point II.....	38
9. The trial court erred in refusing to give appellant's requested Instruction No. 10, specified under Specification of Errors, Specification No. (9), Point II.....	39
10. The trial court erred in refusing to give appellant's requested Instruction No. 11, specified under Specification of Errors, Specification No. (10), Point II.....	39
11. The trial court erred in refusing to give appellant's requested Instruction No. 12, specified under Specification of Errors, Specification No. (11), Point II.....	40
12. The trial court erred in refusing to give appellant's requested Instruction No. 13, specified under Specification of Errors, Specification No. (12), Point II.....	40
Conclusion .....	41

## TABLE OF AUTHORITIES CITED

CASES	PAGE
California-Western States Life Ins. Co. v. Feinstein, 15 Cal. 2d 413, 101 P. 2d 696.....	14, 32, 37, 40
Enelow v. New York Life Insurance Co., 83 F. 2d 550, cert. den. 298 U. S. 680.....	29
Hawley v. Insurance Co., 102 Cal. 651, 36 Pac. 926.....	33
Layton v. New York Life Ins. Co., 55 Cal. App. 202, 202 Pac. 958 .....	38, 39
Maggini v. West Coast Life Ins. Co., 136 Cal. App. 472, 29 P. 2d 63 .....	14, 28, 32
McEwen v. New York Life Ins. Co., 23 Cal. App. 694, 139 Pac. 242 .....	32
McEwen v. New York Life Ins. Co., 42 Cal. App. 133, 183 Pac. 373 .....	32, 37
McEwen v. New York Life Ins. Co., 187 Cal. 144, 201 Pac. 577 .....	14, 28
Nichols v. United States, 68 F. 2d 597.....	26
Palmquist v. Standard Acc. Ins. Co. 3 Fed. Supp. 356.....	29
Pierre v. Metropolitan Life Ins. Co., 22 Cal. App. 2d 346, 70 P. 2d 985.....	14
Robinson v. Occidental Life Ins. Co, 131 Cal. App. 2d 581, 281 P. 2d 39.....	14, 29, 30, 32, 35, 36, 38, 39
San Francisco Lathing Co. v. Penn Mutual Life Ins. Co., 144 A. C. A. 185, 300 P. 2d 715.....	14, 32, 36
Telford v. New York Life Ins. Co., 9 Cal. 2d 103, 69 P. 2d 835 .....	32, 36, 38
Westphall v. Metropolitan Life Ins. Co., 27 Cal. App. 734, 151 Pac. 159 .....	39
Whitney v. West Coast Life Ins. Co., 177 Cal. 74, 169 Pac. 997.....	14, 15, 27, 28, 40

RULES	PAGE
Federal Rules of Civil Procedure, Rule 50(b) .....	2, 3, 4, 30, 41
Federal Rules of Civil Procedure, Rule 59.....	2

#### STATUTES

Civil Code, Secs. 2561-2582.....	12
Insurance Code, Sec. 330.....	12
Insurance Code, Sec. 331.....	12
Insurance Code, Sec. 332.....	12
Insurance Code, Sec. 334.....	13
Insurance Code, Sec. 358.....	13
Insurance Code, Sec. 359.....	13
Insurance Code, Sec. 360.....	13
United States Code Annotated, Title 28, Sec. 1291.....	2
United States Code Annotated, Title 28, Sec. 1332.....	2
United States Code Annotated, Title 28, Sec. 1441.....	2
United States Code Annotated, Title 28, Sec. 1446.....	2

#### TEXTBOOK

131 American Law Reports, p. 608, anno., pp. 617-655.....	14
---	----



No. 15442.

IN THE

# United States Court of Appeals

FOR THE NINTH CIRCUIT

---

THE NATIONAL LIFE AND ACCIDENT INSURANCE COMPANY,

*Appellant,*

*vs.*

VERDA A. GOREY,

*Appellee.*

---

Appeal From the United States District Court for the  
Southern District of California, Central Division.

---

## APPELLANT'S OPENING BRIEF.

---

Statement of Pleadings and Facts Showing Basis of  
Jurisdiction of the United States District Court  
and of the United States Court of Appeals.

The complaint in this action was originally filed by the plaintiff-appellee in the Superior Court of the State of California, in and for the County of Los Angeles on March 5, 1956. The complaint was for recovery of the proceeds alleged to be payable to plaintiff, as beneficiary, on an insurance policy issued by the defendant-appellant on the life of George E. Gorey, viz. the sum of \$9,363.00 with interest [R. 3-5]. On March 16, 1956, the defendant-appellant filed a petition for removal of the action to the United States District Court for the Southern District of

California, Central Division, under Title 28, U. S. C. A., Sections 1441, 1446, 1332, on the ground of diversity of citizenship. The action was thereupon removed to the United States District Court and an answer to the complaint was filed by the defendant-appellant [R. 5-11]. The case was tried in the District Court before a jury, the Honorable William C. Mathes, Judge presiding, and judgment for the plaintiff-appellee on the verdict, in the sum of \$9,431.00, was entered on November 20, 1956 [R. 23]. On November 21, 1956, the defendant-appellant filed its written motion to set aside the verdict and for judgment or for a new trial, in the alternative, under Federal Rules of Civil Procedure, Rules 50(b) and 59 [R. 24-27]. Said motions were heard on December 3, 1956, and were denied, the order denying said motions being entered December 21, 1956 [R. 28]. A notice of appeal to the United States Court of Appeals for the Ninth Circuit from said judgment and from said order denying said motions was filed by the defendant-appellant on January 8, 1957 [R. 29]. The Circuit Court of Appeals has jurisdiction of this appeal from the final decision of the District Court (28 U. S. C. A., Sec. 1291).

### **Statement of Case and Questions Involved.**

This is an action by the beneficiary on a life insurance policy issued by appellant on or about May 1, 1954. The defense was and is: (1) that the insured, George E. Gorey, in his written application for the insurance policy dated April 14, 1954, made material false representations to appellant by making false answers to specific questions in the application, to wit, that he had never had an ailment or disease of the heart, and that he had never consulted any physician, and (2) that the insured, by said false answers in the application and by his failure to advise

appellant of such false statements thereafter, concealed said material facts from appellant, and (3) that before issuance of the policy the insured falsely represented to appellant's medical examiner that he had never undergone an electrocardiogram and concealed from him that he had, and (4) that the insured was not in good health at the time of his application for insurance or delivery of the policy, and (5) that appellant relied upon the application and the insured's answers to said questions therein and upon the medical examiner's report in issuing and delivering the policy to the insured, and is not liable on the policy.

Appellant contends that the evidence is uncontradicted that the insured consulted a physician in October, 1953, less than six months before applying for the insurance policy; that the physician examined the insured on several occasions, took an electrocardiogram of insured, diagnosed his condition as coronary arteriosclerosis, advised the insured that he had a heart disease, and that the insured died in November, 1955, of coronary arteriosclerosis; that appellant relied upon the written application and the insured's answers to the questions therein and upon the medical examiner's report in issuing the policy, and therefore that appellant's motions for a directed verdict and for judgment under F. R. C. P., Rule 50(b), should have been granted.

Appellant further contends that the trial court committed prejudicial error in giving certain jury instructions and in refusing to give certain jury instructions requested by appellant.

The questions involved in this appeal are:

- (1) Was appellant entitled to a directed verdict and to an order setting aside the verdict and for judgment under F. R. C. P., Rule 50(b)?
- (2) If appellant was not entitled to a directed verdict and to judgment under F. R. C. P., Rule 50(b), did the trial court commit prejudicial error in giving certain jury instructions or in refusing to give certain jury instructions requested by appellant?

### Specification of Errors Relied Upon.

#### POINT I.

The Trial Court Erred in Denying Appellant's Motion for a Directed Verdict and for an Order Setting Aside the Verdict and for Judgment Under F. R. C. P., Rule 50(b). The Evidence Establishing Appellant's Defenses of Misrepresentation and Concealment Was Uncontradicted.

#### POINT II.

The Trial Court Committed Prejudicial and Reversible Error in Giving the Following Jury Instructions and in Refusing to Give the Following Jury Instructions Requested by Appellant.

- (1) The trial court erred in giving the following jury instructions [R. 127-128]:

“Answers to questions in an application for insurance are generally deemed material representations of fact, which, if false, may vitiate the policy.

“If an insurance company is misled by misstatements or concealments of an insured person into issuing a policy it would not otherwise have issued, the company is not liable on the policy, regardless of



whether the failure of the insured person to state the true facts as known and understood by him was intentional or unintentional.

The representations of George E. Gorey in his application for insurance in question here were material, if they were such as to mislead the defendant into issuing a policy which the defendant would not otherwise have issued."

The grounds of the objections urged were: (a) that the misrepresentations and concealments were material as a matter of law [R. 135-136], (b) that material misrepresentations or concealments "will" vitiate the policy rather than "may" [R. 136], (c) that inclusion of the clause "and understood by" the insured presented a question not in issue [R. 135].

(2) The trial court erred in giving the following instructions [R. 126, 128]:

"To establish the defense of avoiding that policy of life insurance on the ground of misstatement or concealment by George E. Gorey of material facts, the burden is upon the defendant to prove by a preponderance of the evidence that some material misstatement was made by George E. Gorey, or that said George E. Gorey concealed some material facts from the defendant, and that the defendant would never have issued the policy but for such concealment or misstatement.

If you find from a preponderance of the evidence that George E. Gorey had knowledge of such facts but concealed them from the defendant, as the defendant alleges, and further find that the defendant would never have issued the policy if the defendant had known and understood whatever George E. Gorey may have known and understood with respect to such

matters at the time of the issuance of the policy, then your verdict should be in favor of the defendant.”

The grounds of the objections urged were: (a) that the inclusion of the clause “would never have issued the policy” was error as being contrary to law, (b) the clause “may have known and understood” was contrary to law [R. 135. 136].

(3) The trial court erred in giving the following jury instruction [R. 129; portion objected to quoted]:

“\* \* \* and you further find that \* \* \* the defendant would never have issued the policy if the defendant had known and understood whatever George E. Gorey may then have known and understood with respect to the state of his health, then the insurance policy did not become effective upon delivery. \* \* \*”

The ground of the objection urged was that said portion of the instruction was an incorrect statement of the law applicable [R. 137].

(4) The trial court erred in giving the following jury instruction [R. 124]:

“\* \* \* You should consider each expert opinion received in evidence in this case and give it such weight as you think it deserved; and you may reject it entirely if you conclude the reasons given in support of the opinion are unsound.”

The grounds of the objections urged were that there was no expert opinion received in evidence and that the effect of said instruction was to confuse the jury with respect to its right to reject or disregard the testimony of Dr. Kerchner who gave no expert opinion testimony [R. 134-135].

(5) The trial court erred in refusing to give the following jury instruction (No. 3) requested by appellant [R. 17]:

“You are instructed that if George E. Gorey was treated by a physician before the date of the making of the application for the policy of insurance involved in this case, that is, before April 14, 1954, that fact is presumed to have been within the personal knowledge of George E. Gorey, and if his representations in his application with regard to having ever consulted a physician for any ailment or disease of the heart are false, he was guilty of fraud, although as a matter of fact, he might not have intended to deceive the company, and your verdict should be for the defendant company.”

The ground of objection urged was that the requested instruction was a proper statement of the law applicable to evidence received, authority being cited in the requested instruction [R. 137-138].

(6) The trial court erred in refusing to give the following jury instruction (No. 5) requested by appellant [R. 18]:

“You are instructed that if George E. Gorey, the applicant, concealed the fact that he had consulted a physician concerning which enquiry was made by the defendant company in the application for insurance, it is not necessary that the matter concealed effect the length of the insured’s life. If you find that there was a concealment by reason of the failure of George E. Gorey to disclose his consultations with a physician or physicians, your verdict must be for the defendant company even though you believe that the ailment or disease for which the consultation or consultations was had did not shorten the life of George E. Gorey.”

The ground of objection urged was that the requested instruction was a proper statement of the law applicable to evidence received, authority being cited in the requested instruction [R. 137-138].

(7) The trial court erred in refusing to give the following jury instruction (No. 8) requested by appellant [R. 18]:

“If George E. Gorey concealed any material fact or facts with regard to his medical history, the plaintiff cannot recover in this action and this is true, although you may find that the facts concealed had no connection with the cause of George E. Gorey’s death.”

The ground of objection urged was that the requested instruction was a proper statement of the law applicable to evidence received, authority being cited in the requested instruction [R. 137-138].

(8) The trial court erred in refusing to give the following jury instruction (No. 9) requested by appellant [R. 19]:

“You are instructed that the requirement of fair dealing is laid on both parties to the insurance policy involved in this action. This requirement imposed a duty on the part of George E. Gorey, the insured, to read the insurance policy and the photostatic copy of his application attached thereto upon the delivery thereof to him by the defendant company, and you may assume that he did so and that he had full knowledge of the questions contained in said application and his answers thereto. He also had a duty to report to the defendant company any misrepre-

sentations set forth in or omissions in his application within a reasonable time. If you find that he neglected to so inform the defendant company of any such material misrepresentation or omission, your verdict should be for the defendant company.”

The ground of objection urged was that the requested instruction was a proper statement of the law applicable to evidence received, authority being cited in the requested instruction [R. 137-138].

(9) The trial court erred in refusing to give the following jury instruction (No. 10) requested by appellant [R. 19-20]:

“You are instructed that the fact that George E. Gorey was examined by one of the defendant company’s medical examiners at or about the time of his application for insurance in no way affects the right of the defendant company to deny liability under the policy of insurance involved in this action if a full and truthful disclosure of facts concerning which the defendant company made enquiry was not made by George E. Gorey in his application for insurance.”

The ground of objection urged was that the requested instruction was a proper statement of the law applicable to evidence received, authority being cited in the requested jury instruction [R. 137-138].

(10) The trial court erred in refusing to give the following jury instruction (No. 11) requested by appellant [R. 20]:

“You are instructed that the policy of insurance involved in this action was delivered to George E.

Gorey in May, 1954, and at the time of delivery a photostatic copy of the application therefor was attached thereto; that the policy and the application therefor constituted the entire contract between the defendant company and George E. Gorey. George E. Gorey, over his own signature, declared that each of the statements contained in said application were full, complete, true and without exception, unless such exception was noted. The statements contained in the application thereby became his solemn representations and of the same binding force upon him as though he had himself written them out in his own handwriting and signed them.”

The ground of objection urged was that the requested instruction was a proper statement of the law applicable to evidence received, authority being cited in the requested instruction [R. 137-138].

(11) The trial court erred in refusing to give the following jury instruction (No. 12) requested by appellant [R. 21]:

“You are instructed that if you find that George E. Gorey, in October, 1953, supposing himself to be in need of a physician, did consult a physician and answered such enquiries as the physician deemed pertinent and received aid, advice or treatment which the physician deemed necessary, he had consulted a physician within the meaning of the question asked relative thereto in his application for the insurance policy.”

The ground of objection urged was that the requested instruction was a proper statement of the law applicable to evidence received, authority being cited in the requested instruction [R. 137-138].

(12) The trial court erred in refusing to give the following jury instruction (13) requested by appellant [R. 21-22]:

“The defendant company was entitled to have a full, complete and true statement by George E. Gorey of the names and addresses of physicians he had ever consulted before he applied for the policy of insurance involved in this action insofar as the defendant company made enquiries of George E. Gorey relative thereto at the time he made said application. The written application for the insurance policy involved in this action made by George E. Gorey to the defendant company on or about April 14, 1954 includes the question to George E. Gorey, the applicant: ‘State names and addresses of physicians you have ever consulted and give the occasion by reference to question numbers and letters above.’ If you find that George E. Gorey answered this question in said application by stating that he had never consulted any physicians, and if you further find that before making such application George E. Gorey had consulted a physician, namely, R. R. Kerchner, M. D., your verdict must be for the defendant company.”

The ground of objection urged was that the requested instruction was a proper statement of the law applicable to evidence received, authority being cited in the requested instruction [R. 137-138].

## ARGUMENT.

### POINT I.

THE TRIAL COURT ERRED IN DENYING APPELLANT'S MOTION FOR A DIRECTED VERDICT AND FOR AN ORDER SETTING ASIDE THE VERDICT AND FOR JUDGMENT UNDER F. R. C. P., RULE 50(b). THE EVIDENCE ESTABLISHING APPELLANT'S DEFENSES OF MISREPRESENTATION AND CONCEALMENT WAS UNCONTRADICTED.

#### 1. Summary of Applicable Law on Misrepresentation and Concealment.

Before proceeding with argument under Point I, appellant presents the following summary of the law applicable to its defense.

California Insurance Code, Sections 330 to 361 (based on former Cal. Civ. Code, Secs, 2561-2582), sets forth the basic rules applicable to concealment and misrepresentation by an applicant for life insurance. Several of the more important Insurance Code sections applicable to this case are:

“Section 330. Definition. Neglect to communicate that which a party knows, and ought to communicate, is concealment.”

“Section 331. Effect. Concealment, whether intentional or unintentional, entitles the injured party to rescind insurance.”

“Section 332. Required Disclosures. Each party to a contract of insurance shall communicate to the other, in good faith, all facts within his knowledge which are or which he believes to be material to the contract and as to which he makes no warranty, and which the other has not the means of ascertaining.”



“Section 334. Determination Of Materiality Of Fact Concealed. Materiality is to be determined not by the event, but solely by the probable and reasonable influence of the facts upon the party to whom the communication is due, in forming his estimate of the disadvantages of the proposed contract, or in making his inquiries.”

“Section 358. Falsity: What Constitutes. A representation is false when the facts fail to correspond with its assertions or stipulations.”

“Section 359. Same: Effect. If a representation is false in a material point, whether affirmative or promissory, the injured party is entitled to rescind the contract from the time the representation becomes false.”

“Section 360. Materiality. The materiality of a representation is determined by the same rule as the materiality of a concealment.”

The California law on the subject of concealment and misrepresentation as applied to life insurance is well settled by numerous decisions of the California courts, a summary of which follows. In addition to the cases cited herein as authority, there are a number of other cases in accordance therewith.

A false answer by an applicant for insurance to a *specific* question in a written application as to whether the applicant has ever had a specific ailment or disease constitutes a material misrepresentation and a concealment of a material fact if the applicant had knowledge of such ailment or disease at the time he gave the false answer in the application. Such a misrepresentation and concealment avoids a policy issued in reliance on the application.

A false answer by an applicant for life insurance in a written application for insurance to a *specific* question in the application as to whether the applicant had ever consulted a physician constitutes both a material misrepresentation and a concealment and avoids a policy issued in reliance on the application.

- San Francisco Lathing Co. v. Penn Mutual Life Ins. Co.*, 144 A. C. A. 185, 300 P. 2d 715;  
*Robinson v. Occidental Life Ins. Co.*, 131 Cal. App. 2d 581, 281 P. 2d 39;  
*California-Western States Life Ins. Co. v. Feinstein*, 15 Cal. 2d 413, 101 P. 2d 696;  
131 A. L. R. 608, Ann., pp. 617-655.

While a false representation or concealment by an applicant in a written application in answer to a *general* question as to whether the insured had ever had *any* ailment or disease must relate to something more than a minor or temporary ailment or disease, viz., to a substantial or appreciable disorder, to be material and avoid the policy, a false answer to a specific question as to the applicant's medical history is material *as a matter of law* and avoids the policy. Where the evidence establishes the defendant as a matter of law it is the duty of the trial court to direct a verdict for the insurer.

- Maggini v. West Coast Life Ins. Co.*, 136 Cal. App. 472, 29 P. 2d 63;  
*California-Western States Life Ins. Co. v. Feinstein, supra*, 15 Cal. 2d 413, 101 P. 2d 696;  
*Whitney v. West Coast Life Ins. Co.*, 177 Cal. 74, 169 Pac. 997;  
*Pierre v. Metropolitan Life Ins. Co.*, 22 Cal. App. 2d 346, 70 P. 2d 985;  
*McEwen v. New York Life Ins. Co.*, 187 Cal. 144, 201 Pac. 577.

While it is incumbent on an insurer to prove that the insured had knowledge of the particular ailment or disease relied on as the fact misrepresented or concealed by the applicant in order to avoid the policy, it is presumed as a matter of law that an applicant had knowledge of a prior consultation by him with a physician, at least where the consultation was relatively recent.

*Whitney v. West Coast Life Ins. Co. (supra)*,  
177 Cal. 74, 169 Pac. 997.

## 2. The Evidence Proving Appellant's Defenses Is Uncontradicted.

- (a) **The Evidence Is Uncontradicted That George E. Gorey, the Insured, Represented in Writing to Appellant in His Written Application for the Policy That He Had Never Had an Ailment or Disease of the Heart and That He Had Never Consulted Any Physician.**

It is an admitted fact that the insured, on or about April 14, 1954, made, executed and delivered to appellant at Whittier, California, his written application [Ex. A] for the policy [Ex. 1; R. 12, 34], and that a true copy of the application was attached to and made a part of the policy at the time of the issuance and delivery of the policy to the insured [R. 13, 35]. The original policy in evidence has a photostatic copy of the application attached thereto [Exs. A, 1]. It is also an admitted fact [R. 14, 36], and the application shows on its face among other things, that the application stated, among other things, the following specific questions to be answered by the applicant and contains the following specific answers to said questions, to wit: "Question 54. Have you ever had any ailment or disease of: B. Heart or lungs? Yes or No. No." "Question 60. State names

and addresses of physicians you have ever consulted and give the occasion by reference to question number and letters above. NONE.”

The original application [Ex. A] shows at the bottom the signature in handwriting of the insured (applicant) “George E. Gorey.” The photostatic copy of the original application attached to the original policy when issued [Ex. 1], received in evidence on appellee’s offer, likewise shows said signature and there was no question raised and it is undisputed that the handwritten signature was that of the insured. Directly above insured’s signature on the application appears the following statement (in part) “62. On my own behalf and in behalf of any person who may have or claim any interest in any policy issued hereon: (1) I hereby declare that each of the statements contained herein is full, complete, true, and without exception, unless such exception is noted. (2) I hereby agree that except as provided in the receipt referred to in Item 63, the proposed contract shall not be effective until the policy has been issued, the first premium actually paid and accepted by the Company, and the policy delivered to and accepted by me during the lifetime and good health of the person or persons upon whose death a policy benefit matures. (3) I hereby agree that no statement has been made or information given in connection with this application which is, in any way, inconsistent with anything appearing herein or in the above mentioned receipt.”

Paragraph 23 of the policy [Ex. 1] provides that the policy and copy of the application attached thereto constitute the entire contract.

(b) **The Evidence Is Uncontradicted That Said Representations by the Insured That He Had Never Had an Ailment or Disease of the Heart and That He Had Never Consulted Any Physician Were False and That the Insured Had Knowledge Thereof at the Time of His Application for the Policy.**

The testimony of Dr. R. R. Kerchner, Sr., shows without contradiction the following: that George E. Gorey, the insured, consulted Dr. R. R. Kerchner, Sr., professionally at the doctor's office in Montebello, California, on three different occasions in October, 1953, viz., October 21st, 27th and 31st [R. 48-49]; that the insured had known the doctor for some ten years previously [R. 47-48]; that Dr. Kerchner was in October, 1953 and is a licensed physician [R. 46-47]; that the insured on October 21, 1953, at his first consultation with Dr. Kerchner, complained of pain in his chest and numbness particularly in his left arm upon heavy work that produced excessive exertion [R. 48-49]; that he gave Dr. Kerchner a history of having had such complaints for a month to six weeks before October 21, 1953 [R. 49]; that Dr. Kerchner obtained the insured's medical history for the purpose of diagnosing and treating said complaints [R. 50]; that Dr. Kerchner on October 21, 1953 made a complete general physical examination of the insured from head to foot, including his heart, made a stethoscopic examination [R. 51]; that Dr. Kerchner took an electrocardiogram [Ex. D] and chest X-rays of the insured on October 27, 1953 [R. 51]; that Dr. Kerchner made a tentative diagnosis of coronary insufficiency, coronary artery disease, after taking the electrocardiogram and chest X-rays and sent the electrocardiogram to Dr. Travis Windsor, M.D., a specialist in electrocardiography, cardiac disease and

heart, for his opinion [R. 52-53]; that Dr. Kerchner received a written report [Ex. E] from Dr. Windsor before October 31, 1953, in which report stated that his interpretation of the electrocardiogram tracing was "very strongly suggestive of coronary insufficiency" [R. 54]; that upon receiving Dr. Windsor's report Dr. Kerchner made a final diagnosis of the insured's condition as "coronary heart disease," "coronary artery disease," the technical name for which is "coronary arteriosclerosis" meaning "hardening of the coronary arteries" [R. 55-56]; that the electrocardiogram confirmed his tentative diagnosis that the insured was suffering from said condition and disease [R. 56]; that Dr. Kerchner, in October, 1953, explained his said diagnosis of the insured's condition to the insured and explained to him he had that trouble and prescribed for him lighter work, less forceful exercise, discontinuing smoking and overeating—any thing that might produce increased heart rate which would likely bring on the pain which he experienced and which would cause him perhaps trouble [R. 55]; that Dr. Kerchner also gave the insured a prescription for nitroglycerin tablets to take for the pain and advised him to come in for another electrocardiogram in six months "or before if his condition became more severe" [R. 56-57]; that the insured did not consult Dr. Kerchner regarding his coronary arteriosclerosis condition after October 31, 1953, although in March and April, 1954 he treated the insured on three or four occasions for a sprained knee and hemorrhage of the knee, the last such visit being April 7, 1954 [R. 57] (which was one week before the date of the application for insurance [Ex. A]); that the last time the insured consulted him professionally was August 15, 1954, for a headache [R. 57]. On cross-

examination Dr. Kerchner testified: "Q. And when you advised Mr. Gorey as to his physical condition, especially concerning his heart, did you tell him in lay terms or did you tell him in medical terms what was wrong with him? A. I told him in lay terms. I am certain of that" [R. 59]; that the insured's condition in October, 1953 . . . "might have been very severe at that time. It might not have been, because the record only showed that he had this trouble after he exercised. If he hadn't exercised, we wouldn't know he had it at all" [R. 60]; (referring to the electrocardiogram) "If he didn't have coronary artery disease, he would not have developed the findings, the segment shifts on exercise. I will have to say that was a positive finding. I don't think there is any question" [R. 61].

The above statement of Dr. Kerchner's evidence is, we believe, a fair summary of all of the evidence concerning the insured's physical condition and his knowledge thereof prior to the time he made the written application for the policy. While the appellee testified that the only illness the insured complained of to her before his death was "pains in his chest—about two or three months before," that she didn't know if he took any nitroglycerin tablets before his death, and that she was first aware that he might have had heart trouble was at his death [R. 104-105], such testimony merely goes to *her* knowledge of his condition. Such testimony of appellee does not in any way contradict Dr. Kerchner's clear testimony that the insured had a heart disease for about five and one-half months before he applied for the insurance that the insured knew of his heart disease, and that he thereafter represented to appellant that he had never had any ail-

ment or disease of the heart and had not consulted any physicians.

The only other evidence on the subject of the insured's physical condition is Exhibit 2, introduced in evidence by appellee, and Exhibits B and C. Exhibit 2 is a certified copy of the insured's death certificate signed by Dr. Kerchner, showing he died November 21, 1955, and stating the disease or condition directly leading to death, as "acute myocardial infarction" and the antecedent disease due to "coronary arteriosclerosis". Dr. Kerchner testified that "acute myocardial infarction" is "death of a portion of the heart muscle" [R. 58]. Exhibits B and C are the notice of claim signed by the appellee, and the attending physician's statement signed by Dr. Kerchner, Jr., both exhibits having been delivered to appellant by appellee shortly after the insured's death. Exhibit B dated November 21, 1955, states the insured's cause of death as "heart attack" and Exhibit C states that the insured's immediate cause of death was "myocardial infarction", the contributory causes of death as "coronary arteriosclerosis", that Dr. Kerchner, Sr. was the insured's medical advisor for 25 months, that the doctor was first consulted on October 21, 1953 for the condition which directly or indirectly caused his death, that Dr. Kerchner, Jr. attended the insured in his final illness, that in his opinion the insured suffered from the disease or impairment for 25 months before his death, and that the duration of the insured's coronary arteriosclerosis was 25 months.

Furthermore, appellee stipulated it to be an unadmitted fact not to be contested, that the disease or condition directly leading to the insured's death was acute myocardial infarction, and the antecedent cause to be coronary arteriosclerosis [R. 16].



(c) **The Evidence Is Uncontradicted That the Insured Misrepresented to and Concealed From the Insurer's Medical Examiner and From the Insurer the Fact That He Had Undergone an Electrocardiogram.**

Exhibit A-1, the appellant's form of medical examiner's report, signed by the insured and Suttan H. Groff, M.D., dated April 20, 1954, and being part VII of the application, shows that Dr. Groff, appellant's medical examiner, examined the insured on that date for the life insurance, that he found nothing wrong with the insured, that he verified the insured's answers to Part IV of the application (which includes the insured's misrepresentations that he had never had any heart disease and had never consulted any physicians). Exhibit A-1, said medical examiner's report, which bears the insured's signature, also includes the question and answer:

"F. Has Proposed Insured ever undergone an electrocardiogram? No."

In the summary of the evidence under the previous Point (b) it is pointed out that the evidence shows that Dr. Kerchner took an electrocardiogram of the insured's heart on October 27, 1953, he having requested the insured on October 21, 1953 to come in for that purpose, and that the doctor on October 31, 1953 advised the insured "to come in in six months for another repeat electrocardiogram . . ." [R. 51, 57.] The electrocardiogram taken is Exhibit D. There is no evidence to the contrary and appellee stipulated among other things, that it was an unadmitted fact, not to be contested, that in October, 1953, the insured was examined by Dr. R. R. Kerchner, M.D., that the doctor diagnosed his condition and had him undergo an electrocardiogram [R. 15-16].

- (d) **The Evidence Is Uncontradicted That the Insured Concealed His Medical History From the Insured, That the Insurer Relied on the Application and the Medical Examiner's Report in Issuing and Delivering the Policy, and That It Had No Knowledge of the Misrepresentations or of the Facts Concealed by the Insured.**

It is an admitted fact that the insurer relied upon the application [Ex. 1], on the medical examiner's report [Ex. A-1] and on the retail credit report [Ex. F] and it is specifically admitted that the insurer relied on the answers to questions 54 and 60 (contained in the application) in issuing and delivering the policy to the insured [R. 14-15]. Answers to questions 54 and 60 stated that the insured had never had any ailment or disease of the heart and had never consulted any physician. While it would appear that it would necessarily be presumed from these stipulated facts that the insurer had no knowledge of the facts misrepresented to and concealed from it by the insured, and also that the insurer would not have issued or delivered the policy if it had any such knowledge, the record includes uncontradicted evidence establishing such facts. The testimony of Lawson W. Smith, local district manager and administrative officer of the appellant at all times pertinent to the policy involved in this action, shows that the local district office of appellant did not at any time receive any information or communication from the insured or from any one else on his behalf that any of the answers in the insured's written application [Ex. A] were not correct, and that he had received no information with respect to the insured having consulted Dr. Kerchner until after appellee presented her claim on the policy [R. 75].

The uncontradicted testimony of Jack D. Gwaltney, Senior Underwriter of appellant at its Home Office in

Nashville, Tennessee, shows: that on April 29, 1954 he approved the written application of George E. Gorey, the insured [Ex. A] for the insurance policy in suit; that his duties as underwriter were the selection of risks, viz., to review applications for ordinary life insurance to determine whether the applicant was eligible for the policy applied for; that he had authority to approve applications for policies up to \$10,000, if he determined an applicant was eligible for the policy applied for; that the policy in suit was issued by appellant upon his final approval on the basis of a standard rating; that the only information he had available in passing on the application were the applicant's statements and information in the application, the information in the medical report [Ex. A-1] and the information in the inspection report [Ex. F], and that he relied only on the statements and information contained therein; that if the said statements and information had been true the applicant was eligible for the policy he applied for; that if the application had shown that the applicant had consulted a physician in October, 1953 for a pain in his chest and a numbness and tingling in his arm and hand and that the physician had diagnosed the condition as coronary artery disease, a type of heart disease, and that the physician had made an electrocardiogram of the applicant and confirmed his diagnoses, he would not have approved the application and would have marked the application indicating the applicant was not insurable and would have forwarded the application to the company's medical department; that if the appellant had known that the applicant had been diagnosed as having coronary artery disease in October, 1953 it would have made him an uninsurable risk for life insurance by the company; that no communi-

cation was received by the Home Office of the Company or by him from the insured or from any other person relating to any of the answers to the questions set forth in the application, and that if any such communication had been received it would have been referred to him; that he had searched the papers, records and files in the Home office and had ascertained that no such communication or information had been received by the Company during the insured's lifetime [R. 83-91].

The uncontradicted testimony of Dr. Lloyd C. Miller, Medical Director of the appellant at its Home Office shows: that as associate medical director of the Company in 1954 he had authority to approve or reject applications for ordinary life policies, particularly on medical questions arising in underwriting; that he did not personally see all applications for insurance and if the underwriter approved an application for issuance of a policy he (the medical director) would not see it unless there was a question whether the applicant was eligible for the policy applied for; that he had not participated in the underwriting of Mr. Gorey's application since it had been approved by Mr. Gwaltney as underwriter; that if Mr. Gorey's application had been referred to him and it had revealed that Mr. Gorey in October, 1953, had consulted a physician for a pain in his chest and a numbness and tingling of the arm and hand and that the physician had diagnosed the condition as coronary artery disease after an electrocardiogram had been taken, the application would have been rejected and declined; that a diagnosis of coronary artery disease within one year prior to the date of the application would mean a material and substantial additional risk for a life insurance company in issuing a policy on that applicant; that such a disease

increases the risk of a premature death to such an extent that the applicant is an uninsurable risk [R. 93-94, 102-103].

The uncontradicted testimony of Eldon Stevenson, Jr., President of the appellant company, corroborates Mr. Gwaltney's testimony herein referred to showing that appellant had no knowledge of the insured's concealed medical history, viz., that the appellant's records do not indicate that any agent or employee of the appellant ever knew or had any reason to believe, before Mr. Gorey's death, that Mr. Gorey had ever consulted any doctor or had been ill or had any disease of any kind; that on April 30, 1954 (date of the policy) the only records, information and reports covering Mr. Gorey were his application [Ex. A] the medical examiner's report [Ex. A-1] and the credit report [Ex. F]; and that on April 30, 1954 the appellant had no information in its possession concerning any illness or disease or medical treatment or advice of Mr. Gorey excepting the information set forth in the application, medical report and credit report that Mr. Gorey had never had any illness or disease and had never received any medical treatment or advice and had not undergone an electrocardiogram [R. 98-99].

**(e) The Evidence Is Without Conflict That the Insured Was Not in Good Health When the Policy Was Delivered to and Accepted by the Insured.**

Part VI, Paragraph 62(2) of the application provides, in part, an agreement by the insured that "the proposed contract shall not be effective until the policy has been issued, . . . and the policy delivered to and accepted by me during the lifetime and good health of the person or persons upon whose death a policy benefit matures."

As pointed out under paragraph (b) above the evidence shows, without conflict, that the insured was not in "good health" when the policy was delivered to and accepted by him on or about May 1, 1954. The evidence shows that the insured had been diagnosed by Dr. Kerchner in October, 1953, as having "coronary heart disease", "coronary artery disease", "coronary arteriosclerosis" [R. 55-56]. It is established that the heart disease continued from October, 1953 to the date of the insured's death on November 21, 1955 by the insured's death certificate [Ex. 2] showing the antecedent cause of death as "coronary arteriosclerosis", and by the attending physician's statement [Ex. C] showing the contributory cause of death as "coronary arteriosclerosis" and that the insured had suffered from the disease (coronary arteriosclerosis) for 25 months before his death, viz, since October, 1953. This evidence is not contradicted. Therefore, the policy did not become effective under the agreement in the application.

**3. Appellant's Motions for a Directed Verdict and for Judgment Under Rule 50(b) Should Have Been Granted. The Judgment and Order Denying the Motions Should Be Reversed and Judgment for Appellant Directed.**

The rule applicable to a determination of this question, as this court stated in *Nichols v. United States* (C. C. A. 9th), 68 F. 2d 597, page 600, is:

"The rule in the federal courts is that there must be more than a scintilla of evidence to entitle a case to go to a jury. *U. S. v. Lyle et al.* (C. C. A.) 54 F. 2d 357, 358. A case cannot be submitted to a jury upon speculation or mere probabilities. *U. S. v. Crume* (C. C. A.) 54 F. 2d 556, 558."

Appellant believes that it has fully and fairly summarized the evidence in this case. Not only is there not sufficient evidence within the "scintilla" rule but there is *no* evidence in the record contradicting the evidence establishing the appellant's defenses of misrepresentation and concealment, and that the insured was not in good health when the policy was delivered. Not only the facts but all inferences reasonably to be drawn therefrom as, supported by the overwhelming weight of the evidence, point so strongly in favor of the appellant that reasonable men could not possibly come to a conclusion to the contrary.

Reference is made to the following cases holding a directed verdict to be proper in cases similar on the facts to the case at bar. In *Whitney v. West Coast Life Ins. Co.*, 177 Cal. 74, 169 Pac. 997, the application for life insurance included specific questions as to whether the applicant had ever had a disease of the heart, to which he answered "No", and if he had been attended by a physician, to which he answered "Dr. Chichester" for a burn of arm and chest. The insured died of acute myocarditis, a heart disease. The evidence showed that he had consulted another doctor (not named) for shortness of breath which doctor had diagnosed his condition as myocarditis and had told the insured of his diagnosis, using the word "myocarditis". The appeal was from the judgment for the plaintiff and the order denying a new trial (not from a motion for judgment *n.o.v.*). At page 81 of the opinion the California Supreme Court stated, in reversing the judgment and order:

"Of course, we cannot tell what new evidence may be forthcoming if the cause be retried, but unless some very positive proof available to overcome the

As pointed out under paragraph (b) above the evidence shows, without conflict, that the insured was not in "good health" when the policy was delivered to and accepted by him on or about May 1, 1954. The evidence shows that the insured had been diagnosed by Dr. Kerchner in October, 1953, as having "coronary heart disease", "coronary artery disease", "coronary arteriosclerosis" [R. 55-56]. It is established that the heart disease continued from October, 1953 to the date of the insured's death on November 21, 1955 by the insured's death certificate [Ex. 2] showing the antecedent cause of death as "coronary arteriosclerosis", and by the attending physician's statement [Ex. C] showing the contributory cause of death as "coronary arteriosclerosis" and that the insured had suffered from the disease (coronary arteriosclerosis) for 25 months before his death, viz, since October, 1953. This evidence is not contradicted. Therefore, the policy did not become effective under the agreement in the application.

**3. Appellant's Motions for a Directed Verdict and for Judgment Under Rule 50(b) Should Have Been Granted. The Judgment and Order Denying the Motions Should Be Reversed and Judgment for Appellant Directed.**

The rule applicable to a determination of this question, as this court stated in *Nichols v. United States* (C. C. A. 9th), 68 F. 2d 597, page 600, is:

"The rule in the federal courts is that there must be more than a scintilla of evidence to entitle a case to go to a jury. *U. S. v. Lyle et al.* (C. C. A.) 54 F. 2d 357, 358. A case cannot be submitted to a jury upon speculation or mere probabilities. *U. S. v. Crume* (C. C. A.) 54 F. 2d 556, 558."



Appellant believes that it has fully and fairly summarized the evidence in this case. Not only is there not sufficient evidence within the "scintilla" rule but there is *no* evidence in the record contradicting the evidence establishing the appellant's defenses of misrepresentation and concealment, and that the insured was not in good health when the policy was delivered. Not only the facts but all inferences reasonably to be drawn therefrom as, supported by the overwhelming weight of the evidence, point so strongly in favor of the appellant that reasonable men could not possibly come to a conclusion to the contrary.

Reference is made to the following cases holding a directed verdict to be proper in cases similar on the facts to the case at bar. In *Whitney v. West Coast Life Ins. Co.*, 177 Cal. 74, 169 Pac. 997, the application for life insurance included specific questions as to whether the applicant had ever had a disease of the heart, to which he answered "No", and if he had been attended by a physician, to which he answered "Dr. Chichester" for a burn of arm and chest. The insured died of acute myocarditis, a heart disease. The evidence showed that he had consulted another doctor (not named) for shortness of breath which doctor had diagnosed his condition as myocarditis and had told the insured of his diagnosis, using the word "myocarditis". The appeal was from the judgment for the plaintiff and the order denying a new trial (not from a motion for judgment *n.o.v.*). At page 81 of the opinion the California Supreme Court stated, in reversing the judgment and order:

"Of course, we cannot tell what new evidence may be forthcoming if the cause be retried, but unless some very positive proof available to overcome the

necessary deductions arising from the conduct of the assured, it would be the duty of the trial court to decline to submit the question of fact to a jury.”

In *Maggini v. West Coast Life Ins. Co.*, 136 Cal. App. 472, 29 P. 2d 63, the application for insurance specifically inquired if the applicant had ever raised or spat blood and if he had ever consulted a physician for or had symptoms of lung disease. He answered “no”. The evidence showed the insured had consulted a physician for pneumonia in both lungs and that he had spat blood. After holding the misrepresentations to be material as a matter of law, the appellate court reversed judgment on a verdict for the plaintiff and the order denying a motion for judgment *n.o.v.* and directed judgment for the defendant insurer on the ground that there was “no evidence direct or inferential which supports the verdict” and that the motion for judgment *n.o.v.* should have been granted.

In *Pierre v. Metropolitan Life Ins. Co.*, 22 Cal. App. 2d 346, 70 P. 2d 985, the applicant falsely answered specific questions as to whether he had ever had paralysis and what physicians he had consulted. Holding that uncontradicted evidence of false answers to the specific questions showed a misrepresentation and concealment of material facts as a matter of law, which avoided the policy, the court reversed the judgment on a verdict for the plaintiff and the order denying a motion *n.o.v.*

In *McEwen v. N. Y. Life Ins. Co.*, 187 Cal. 144, 201 Pac. 577, the application inquired as to what illnesses, diseases or accidents the applicant had had. He answered

typhoid pneumonia. The evidence showed that he had an accident in which his chest was injured. The court affirmed the trial court's judgment for the defendant-insurer on a directed verdict, stating that the evidence conclusively showed that the question as to prior accidents had been falsely answered.

In *Palmquist v. Standard Acc. Ins. Co.*, 3 Fed. Supp. 356 (D. C. Cal.), the application included a question as to whether the applicant had ever had a gastric ulcer, which he answered in the negative. On uncontradicted evidence that the answer was false, the court held that the false representation was material as a matter of law, and granted the insurer's motion for a directed verdict.

In *Enelow v. New York Life Insurance Co.*, 83 F. 2d 550 (C. C. A. 3rd) (cert. den. U. S. Sup. Ct. 298 U. S. 680) the appellant falsely answered in the negative a question as to whether he had ever consulted a physician for or suffered from any ailment or disease of the heart, blood vessels or lungs. The uncontradicted evidence showed that he had consulted several doctors, their diagnosis having been "coronary disease" after they took X-rays of the heart and an electrocardiogram. One doctor had told the applicant "he had a weakness of the heart". The insured died from the heart disease. The court affirmed the judgment on directed verdict for the insurer.

In concluding the argument under Point I, reference is made to *Robinson v. Occidental Life Ins. Co.*, 131 Cal. App. 2d 581, 281 P. 2d 39. Although it is not a jury case and therefore does not involve the matter of a

directed verdict, the *Robinson* case is not only very similar to this case on the facts but is one of the more recent California cases on misrepresentation and concealment. There, the insured falsely answered specific questions in his application for life insurance as to whether he had ever had any heart disease and as to physicians he had consulted, the evidence showing that he concealed in his application that he had vascular hypertension, a heart disease, and that he had consulted a physician therefor and had been advised of the physician's diagnosis of that condition. At page 586 the court stated, in affirming judgment for the insurer:

“An insurance company is entitled to determine for itself what risks it will accept, and therefore to know all the facts relative to the applicant's physical condition. It has the unquestioned right to select those whom it will insure and to rely upon him who would be insured for such information as it desires as a basis for its determination to the end that a wise discrimination may be exercised in selecting its risks. (*Mutual Life Ins. Co. v. Hurni Packing Co.*, 260 F. 641, 645 [171 C. C. A. 405].)”

In the case at bar the evidence overwhelmingly established, without any conflict or contradiction, that the insured knowingly misrepresented to and concealed from the insurer material facts relied on by the insurer in issuing the policy. Appellant was entitled to a directed verdict and to judgment under Rule 50(b).

POINT II.

THE TRIAL COURT COMMITTED PREJUDICIAL AND REVERSIBLE ERROR IN GIVING THE FOLLOWING JURY INSTRUCTIONS AND IN REFUSING TO GIVE THE FOLLOWING JURY INSTRUCTIONS REQUESTED BY APPELLANT.

- (1) The Trial Court Erred in Giving the Jury Instruction Specified Under Specification of Errors, Specification No. (1), Point II.

Said instruction was erroneous and prejudicial in that: (a) the question of the materiality of the insured's answers to specific questions in his application was left to the jury to decide as a question of fact, whereas such question is a matter of law for the court; and (b) the answers involved were answers to specific questions in the written application, viz. whether the applicant had ever had an ailment or disease of the heart, and whether he had ever consulted any physician, which answers were each material as a matter of law, and the jury should have been instructed that each such answer was material; and (c) the jury was instructed that material false representations *may* vitiate the policy, whereas there is no question but that such representations do vitiate the policy; and (d) the statement "regardless of whether the failure of the insured person to state the true facts as known and understood by him" cast a burden on appellant to prove that the insured *understood* the "facts" (meaning the facts misrepresented or concealed), which presented a question not in issue and cast on the insurer a burden not imposed on an insurer by law.

The California law on this point is that the question of the materiality of an answer by an applicant for life insurance to a specific question in a written application

as to whether (a) the applicant has ever had a specified ailment or disease, or (b) has ever consulted a physician, is a question of law for the court and not a question of fact for the jury to decide. It is also the law that false answers to any such specific questions are material as a matter of law and do avoid a policy issued in reliance on any such answer in a written application, and that it is the court's duty to so instruct the jury.

*McErwen v. New York Life Ins. Co.*, 23 Cal. App. 694 at 698, 139 Pac. 242;

*McErwen v. New York Life Ins. Co.*, 42 Cal. App. 133, 183 Pac. 373;

*California-Western States Life Ins. Co. v. Feinstein*, 15 Cal. 2d 413, 101 P. 2d 696;

*Maggini v. West Coast Life Ins. Co.*, 136 Cal. App. 472, 29 P. 2d 63;

*San Francisco Lathing Co. v. Penn Mutual Life Ins. Co.*, 144 A. C. A. 185, 300 P. 2d 715;

*Robinson v. Occidental Life Ins. Co.*, 131 Cal. App. 2d 531, 586, 281 P. 2d 39;

*Telford v. New York Life Ins. Co.*, 9 Cal. 2d 103, 105, 69 P. 2d 835.

It is incumbent for an insurer who seeks to avoid a policy on the ground of a false answer or concealment of facts, to prove that the applicant for insurance had knowledge of the facts covered by the questions in the application, but an insurer has no burden to prove the insured's understanding.

The "facts" involved here were quite simple, viz., the insured's history of any ailment or disease of the heart and whether he had consulted any physician. The insured's knowledge of his doctor's diagnosis of heart

disease was sought by one question. His knowledge of his own consultation with his physician was sought by the other question. The uncontradicted evidence on the question of the insured's knowledge of his having heart disease was the testimony of Dr. Kerchner that the insured had consulted him on three occasions in October 1953 for pains in the chest and arm; that the doctor had examined and treated him for heart disease and prescribed for him; and that the doctor had advised him he had a heart disease, as pointed out herein in appellant's argument under Point I. Appellee offered no evidence showing or tending to show that the insured did not fully understand these simple questions and the facts called for by them. Said instruction was clearly erroneous and prejudicial on all points specified.

**(2) The Trial Court Erred in Giving the Jury Instructions Specified Under Specification of Errors, Specification No. (2), Point II.**

Such instructions submitted to the jury the question of whether the insurer would have issued the policy if it had had knowledge of the misrepresented and concealed facts at the time it issued the policy and placed on the insurer the burden of establishing, to the jury's satisfaction, that it would never have issued the policy had it known such facts. The question of whether the insurer would have issued the policy, if, indeed it is pertinent, which is doubtful, is necessarily involved in a determination of whether or not the misrepresented or concealed facts are material. (*Hawley v. Ins. Co.*, 102 Cal. 651, 654, 36 Pac. 926.) As hereinabove pointed out, the materiality of a misrepresentation or concealment in a written application, in answer to specific questions, is for the trial court to determine and not for the jury.

If such are determined to be material, the policy is thereby vitiated or avoided, and if not material, the policy is not avoided thereby. Further, as previously pointed out, the facts misrepresented to and concealed from the insurer in this case are material as a matter of law. Lastly, the question of whether or not appellant would have issued the policy had it known the true facts should not have been submitted to the jury in any event, since the parties stipulated that appellant relied on the application and these specific answers in issuing the policy [R. 36]. Reliance necessarily assumes that the insurer would not have issued the policy had it had knowledge of the matters in question.

**(3) The Trial Court Erred in Giving the Jury Instruction Specified Under Specification of Errors, Specification No. (3), Point II.**

This instruction includes the same erroneous language and issues requiring the jury to find that the insurer would never have issued the policy and presenting the question of the insured's understanding of the facts, which points and appellant's objections thereto have been specified above with respect to the instructions covered under specification No. (2) and will not be repeated. The instruction referred to in specification (3) was, however, applied to a different matter, viz., the issue of whether the insured was in good health when the policy was delivered to him.



(4) The Trial Court Erred in Giving the Jury Instruction Specified Under Specification of Errors, Specification No. (4), Point II.

By this instruction the jury was advised that it might reject entirely the testimony of an expert witness. The only witness who conceivably could have been referred to was Dr. R. R. Kerchner, called by appellant. A very substantial portion of appellant's defense rested on this doctor's testimony. He was not called as an expert witness and did not testify as an expert. He gave the facts respecting the insured having consulted him, the history he was given by the insured, the examination he made, his diagnosis of the insured's condition, the fact that he told the insured he had a heart disease, and the treatment he prescribed. While the doctor's diagnosis of heart disease was of course based on his opinion when the diagnosis was made, the question of whether or not his diagnosis of heart disease was or was not correct was not an issue in this case. The true issue as to the matter of heart disease, was not whether the insured actually had a heart disease when he applied for the insurance but whether he had concealed from or misrepresented to the insurer the facts concerning his medical history relating to heart disease and any consultations had with physicians, viz., that he had consulted a physician and had been advised by the physician that he had a heart disease. This distinction is clearly pointed out in the *Robinson* case, *supra* (131 Cal. App. 2d 531 at p. 585):

“. . . In her zeal to keep the inquiry directed to the subject of her husband's heart trouble, appellant quotes both doctors, Walker and Davis, that there was no heart trouble as of August 8, 1951. Such was not the issue, but rather it was: had her husband concealed knowledge of his vascular hypertension

from the insurance companies? They had a right to know all he knew on that subject whereby they might intelligently decide whether he was an insurable risk. (Mutual Life Ins. Co. v. Hurni, supra.) It was not incumbent upon respondents to investigate Mr. Robinson's statements made to the examiner. It was his duty to divulge fully all he knew. No authority is cited and none will be found holding that an insured or his beneficiaries may escape the consequences of his deception by placing upon the insurer the burden of investigating his verified statements. (Layton v. New York Life Ins. Co., 55 Cal. App. 202, 205 [202 P. 958].)"

The effect of this instruction undoubtedly was to mislead the jurors into believing that they had a right to disregard the doctor's testimony which is not the law applicable to factual testimony.

**(5) The Trial Court Erred in Refusing to Give Appellant's Requested Instruction No. 3, Specified Under Specification of Errors, Specification No. (5), Point II.**

This requested instruction is a proper statement of the law regarding the legal effect of a misrepresentation or concealment as to prior consultations with physicians by an applicant for life insurance in a written application for the insurance, where the misrepresentation or concealment is accomplished by means of false answers to specific questions in the application.

*Telford v. New York Life Ins. Co.*, 9 Cal. 2d 103, 69 P. 2d 835;

*Robinson v. Occidental Life Ins. Co.*, 131 Cal. App. 2d 581, 281 P. 2d 39;

*San Francisco Lathing Co. v. Penn Mutual Life Ins. Co.*, 144 A. C. A. 185, 300 P. 2d 715.

The evidence introduced by appellant, as pointed out under appellant's argument, Point I, showed that the insured consulted Dr. Kerchner on three occasions in October, 1953 and was then treated by him and advised that he had a heart disease. The written application was dated April 14, 1954. This was a vital defense and appellant was entitled to have its requested instruction No. 3 given.

**(6) The Trial Court Erred in Refusing to Give Appellant's Requested Instruction No. 5, Specified Under Specification of Errors, Specification No. (6), Point II.**

Appellant was entitled to an instruction that a concealment as to the insured having consulted a physician would entitle it to a verdict regardless of whether the ailment, or disease for which the consultation was had affected or did not affect the length of the insured's life. The requested instruction correctly stated the applicable law.

*McEwen v. New York Life Ins. Co.*, 42 Cal. App. 133, at pp. 146-147, 183 Pac. 373;

*California-Western States Life Ins. Co. v. Feinstein*, 15 Cal. 2d 413, 101 P. 2d 696.

**(7) The Trial Court Erred in Refusing to Give Appellant's Requested Instruction No. 8, Specified Under Specification of Errors, Specification No. (7), Point II.**

Said instruction, while similar to requested instruction No. 5, is broader and covers concealment by the insured not only of prior consultations with physicians but also the insured's medical history as to heart disease. It states the law applicable. (See cases cited under specification (6).)

(8) The Trial Court Erred in Refusing to Give Appellant's Requested Instruction No. 9, Specified Under Specification of Errors, Specification No. (8), Point II.

Said instruction correctly states the applicable law.

*Telford v. New York Life Ins. Co.*, 9 Cal. 2d 103, 69 P. 2d 835;

*Robinson v. Occidental Life Ins. Co.*, 131 Cal. App. 2d 581, 281 P. 2d 39;

*Layton v. New York Life Ins. Co.*, 55 Cal. App. 202, 202 Pac. 958.

The evidence showed that the appellant's procedure as to applications was that the soliciting agent for issuance of a policy would ask the applicant the questions set forth in the written application, the agent would then write the answers given on the form in his handwriting, request the applicant to review the questions answered, and if found correct then to sign the application [R. 76]. The evidence further showed that the appellant did not receive any information or communication from or on behalf of the insured after delivery of the policy to him that any of the answers in the application were not correct [R. 75, 90-91]. Since an insured not only has a duty under the law to answer questions in an application truthfully but has the additional and affirmative duty of advising the insurer of any misstatements in the application within a reasonable time after delivery to him of the policy with attached copy of his application, appellant was entitled to such an instruction and the failure of the court to give same or any instruction on that point was prejudicial error.

- (9) The Trial Court Erred in Refusing to Give Appellant's Requested Instruction No. 10, Specified Under Specification of Errors, Specification No. (9), Point II.

Said requested instruction correctly states the applicable law.

*Robinson v. Occidental Life Ins. Co.*, 131 Cal. App. 2d 581, 281 P. 2d 39.

Since it was an admitted fact that the insured was examined by one of appellant's medical examiners before the policy was issued [R. 36-37], this requested instruction was very important; otherwise the jury might believe that appellant had no right to rely on the written application even though the application included false answers as to the applicant's medical history.

- (10) The Trial Court Erred in Refusing to Give Appellant's Requested Instruction No. 11, Specified Under Specification of Errors, Specification No. (10), Point II.

This requested instruction correctly states the applicable law.

*Layton v. New York Life Ins. Co.*, 55 Cal. App. 202, 202 Pac. 958;

*Westphall v. Metropolitan Life Ins. Co.*, 27 Cal. App. 734, 151 Pac. 159.

Appellant was entitled to such an instruction covering the legal effect of the statements in the written application and failure to give same was prejudicial error.

(11) The Trial Court Erred in Refusing to Give Appellant's Requested Instruction No. 12, Specified Under Specification of Errors, Specification No. (11), Point II.

Said requested instruction correctly stated the law applicable.

*California-Western States Life Ins. Co. v. Feinstein*, 15 Cal. 2d 413, 101 P. 2d 696;

*Whitney v. West Coast Life Ins. Co.*, 177 Cal. 74, 169 Pac. 997.

It was important and appellant was entitled to an instruction as to what constituted "consulting" a physician within the meaning of question 60 in the application the evidence showing that the insured had called upon Dr. Kerchner for professional aid, advise and treatment in October, 1953 [R. 48-49].

(12) The Trial Court Erred in Refusing to Give Appellant's Requested Instruction No. 13, Specified Under Specification of Errors, Specification No. (12), Point II.

Appellant was entitled to instruction No. 13, viz., that the jury would have the duty of returning a verdict for appellant if the jury found that the insured had falsely answered the question in the application as to what physicians he had consulted, the answer to such question being material as a matter of law as previously pointed out in the authorities cited herein.

**Conclusion.**

Appellant was entitled to a directed verdict and to judgment on its motion under F. R. C. P., Rule 50(b). Judgment for appellee should be reversed and entry of judgment in favor of appellant should be directed.

In any event the trial court committed prejudicial error in giving the instructions objected to and in refusing to give the specified instructions requested by appellant and judgment for appellee should be reversed.

Respectfully submitted,

OVILA N. NORMANDIN, and  
JOHN C. MORROW,

By JOHN C. MORROW,

*Attorneys for Appellant, The National Life  
and Accident Insurance Company.*





No. 15442

IN THE

# United States Court of Appeals

FOR THE NINTH CIRCUIT

---

THE NATIONAL LIFE AND ACCIDENT INSURANCE COM-  
PANY,

*Appellant,*

*vs.*

VERDA A. GOREY,

*Appellee.*

---

BRIEF OF APPELLEE, VERDA A. GOREY.

---

FILE

MAY 23 1957

PAUL P. O'BRIEN, C

L. E. McMANUS,  
8505 Rosemead Boulevard,  
Rivera, California,  
*Attorney for Appellee Verda A. Gorey.*



## TOPICAL INDEX

	PAGE
The pleadings .....	1
The issues involved.....	2
Argument .....	3
The evidence .....	3
Points and authorities in support of verdict and judgment.....	14
Court was right in denying motion for directed verdict.....	14
Defendant did not make false answers to any of the questions contained in the application for insurance.....	15
Appellant is estopped to assert the defense of material mis- representation by the insured.....	16
The evidence supports a jury finding that the insured was not aware of a heart ailment or disease, if he in fact did have a heart ailment or disease.....	19
Cause of death.....	20
Question 60 of the application.....	20
The electrocardiogram .....	22
The good health of the insured.....	23
The instructions .....	24
Conclusion .....	24

## TABLE OF AUTHORITIES CITED

CASES	PAGE
Aetna Life Ins. Co. v. Hub Hosiery Mills, 170 F. 2d 547, 74 Fed. Supp. 599.....	18
Boggio v. Western States Life Insurance Company, 108 Cal. App. 2d 597, 239 P. 2d 144.....	16
Brubaker v. Beneficial Standard Life Insurance Company, 130 Cal. App. 2d 340, 278 P. 2d 966.....	23
California-Western States Life Insurance Co. v. Feinstein, 15 Cal. 2d 413, 101 P. 2d 696.....	14
Chase v. Sunset Mutual Life Insurance Association, 101 Cal. App. 625 .....	23
Robinson v. Occidental Life Ins. Co., 131 Cal. App. 2d 581, 281 P. 2d 39 .....	14
San Francisco Lathing Co. v. Penn Mutual Life Ins. Co., 144 A. C. A. 185, 300 P. 2d 715.....	14
Stipich v. Metropolitan Life Ins. Co., 277 U. S. 311, 72 L. Ed. 895, 48 S. Ct. 512.....	20

### STATUTES

Insurance Code, Sec. 10113.....	22
---------------------------------	----

### TEXTBOOKS

Cooley's Briefs on Insurance.....	18
-----------------------------------	----

No. 15442

IN THE

# United States Court of Appeals

FOR THE NINTH CIRCUIT

---

THE NATIONAL LIFE AND ACCIDENT INSURANCE COM-  
PANY,

*Appellant,*

*vs.*

VERDA A. GOREY,

*Appellee.*

---

BRIEF OF APPELLEE, VERDA A. GOREY.

---

## The Pleadings.

The complaint on file seeks to recover on a policy of life insurance issued by appellant on the life of George E. Gorey, deceased.

The answer admits the issuance of the insurance policy, and the death of the insured therein, but denies liability on the part of appellant by reason of alleged false statements and concealments contained in the application signed by the insured and alleged false statements made by the insured to appellant's medical examiner.

### The Issues Involved.

The issues involved in this appeal as raised by appellant are:

1. Did the insured, George E. Gorey, in his written application for insurance make material false representations to appellant?

2. Did the insured by means of false answers in the application conceal material facts from appellant?

3. Did the insured falsely represent to appellant's medical examiner that he had never undergone an electrocardiogram?

4. Was the insured in good health at the time of his application for insurance and delivery of the policy?

5. Did appellant rely upon the application, appellant's medical examiner's report, and the report of inspection by defendant's agent, and is the appellee liable on the policy?

## ARGUMENT.

### The Evidence.

The parties entered into the following stipulation at the trial [R. 34]:

“Mr. McManus: Your Honor, I believe that counsel for the defendant and myself can arrive at some stipulations.

The Court: Very well, Mr. McManus, will you stand at the lecturn and present them.

Mr. McManus: This is a statement of admitted facts. One, that the plaintiff is and at all times mentioned in the complaint was a resident and citizen of the State of California and is the surviving wife of George E. Gorey, now deceased. Two, that the defendant is a corporation organized and existing under the laws of the State of Tennessee and a resident and citizen of the State of Tennessee and that it was and is doing business in the County of Los Angeles, State of California. Three, that on or about April 14, 1954, said George E. Gorey made and executed and delivered to the defendant in Whittier, California, his written application [8] for the issuance to and delivery to him of a life insurance policy on his life in the amount of \$3,300 upon the family income plan; that a true copy of said application marked Exhibit A is attached to and made part of the defendant's answer on file herein. Four, that said George E. Gorey paid defendant the sum of \$8.34 on or about April 14, 1954, as the first monthly premium on said policy. Five, that the defendant relied upon the application, the report of the medical examiner of the defendant and the report of inspection by the defendant's agent and under date of April 30, 1954, it issued and thereafter

delivered to George E. Gorey its life insurance policy number 2081957 on his life and that plaintiff was and is named as beneficiary in said policy. That said life insurance policy provides that in the event of the death of said George E. Gorey during the second year of the policy the beneficiary would have the right to elect to receive payment of the sum of \$8,824 as commuted proceeds payable under said policy in lieu of all other settlement provisions thereunder in full settlement of all claims and rights of the beneficiary. Six, that said application, Exhibit A, and said policy of insurance provides that the policy would become effective only if delivered thereafter to the insured during his life in good health and that a true copy of said application, Exhibit A aforesaid, was attached to and made part of said policy at the [9] time of issuance and delivery thereof to said George E. Gorey. Seven, that said George E. Gorey died on November 19, 1955, at Whittier, California, and up to that time all premiums called for by said policy had been fully paid. Eight, that after the death of said George E. Gorey and before the commencement of plaintiff's action herein, plaintiff gave defendant notice and proofs of death of said George E. Gorey and demanded payment of the sum she claimed to be due under said policy. Nine, that after said receipt by defendant of the notice and proofs of death of said George E. Gorey and before plaintiff filed her action herein, the defendant made an investigation of the facts and circumstances connected with his applying for and securing said policy of insurance and that it advised the plaintiff of said investigation of the defendant and told the plaintiff it was not liable for and it would not pay her the death benefit mentioned in the policy nor any other sum except the sum of



premiums it had received thereunder plus interest on the same from the dates of payment. Thereafter that defendant advised plaintiff said premiums and interest amounted to \$168.07. Ten, that said application, Exhibit A aforesaid, stated among other things the following questions to be answered by the applicant and contains the following answers to said questions, to wit, Question 54, 'Have you ever had any ailment or disease, (b) Heart or lungs, yes or no?' 'No.' That means that answer is 'No' counsel. [10]

Mr. Morrow: That means that's the answer that's given to the question?

Mr. McManus: Yes. Question 60, 'State names and addresses of physicians you have ever consulted and give the occasion by reference to question number and letters above.' 'None.'

Mr. Morrow: The answer is 'No,' counsel?

Mr. McManus: Yes. That the defendant relied upon said application and on said answers to said questions in issuing and delivering said policy to said George E. Gorey. Eleven, that on April 20, 1954, said George E. Gorey was examined by Sutton H. Groff, M.D., defendant's medical examiner, at Montebello, California in connection with said application, Exhibit A aforesaid. That said medical examiner's written report of said examination was set forth on the reverse side of said application, Exhibit A aforesaid, and was delivered to the defendant before said policy was issued. That said medical examiner's report was exhibited to plaintiff's counsel on May 11, 1956, and that the defendant relied upon said medical examiner's report in issuing and delivering said policy to said George E. Gorey.

Mr. Morrow: Pardon me just a moment. The stipulation is correct, Mr. McManus. May I inquire privately of Mr. McManus, your Honor?

The Court: You may.

Mr. McManus: And it is further stipulated that the [11] defendant tendered and delivered to plaintiff its check number 42127 in the plaintiff's favor for \$168.07 representing the premiums theretofore paid on said policy plus interest.

Mr. Morrow: So stipulated.

The Court: I assume we include in that stipulation that the plaintiff refused to accept that check?

Mr. Morrow: We were just discussing that matter. We don't know quite how to put it. Anyway, that's the understanding. She didn't accept the check in payment of the death benefit provided in the policy.

Mr. McManus: That's correct, your Honor."

Dr. R. R. Kerchner, Sr., testified in part as follows [R. 55]:

"Q. And after receiving the report from Dr. Windsor, did [31] you make a final diagnosis of Mr. Gorey's condition? A. I did.

Q. What diagnosis did you make at that time? A. I made a diagnosis—while he was present I made the diagnosis of coronary heart disease of probably not too severe, that is, too far advanced, but there was no way of telling that to him definitely but I explained to him he did have this trouble and prescribed for him a regime of lighter work, less forceful exercise, discontinuing smoking and over-eating perhaps, anything that might produce increased rate of the heart which would likely bring on the pain which he experienced and which would cause him perhaps trouble.

Q. If I may interrupt you, did you explain to Mr. Gorey on October 31 or at least one of the visits your diagnosis was as you have prescribed? A. I did.

Q. Will you explain briefly in so-called layman's language what coronary insufficiency means. A. Coronary insufficiency means an insufficient amount of blood coming from the aorta through the coronary arteries. There are two arteries, one left and one right that encircle the heart coming over the top and around the heart that supply the blood to muscle of the heart which enables it to beat and when the heart does not supply enough blood or the blood is not able to get through these arteries sufficiently then [32] pain develops because the muscle does not have enough oxygen which comes by way of the blood stream. That's coronary insufficiency.

Q. As I understand it, you diagnosed his condition as coronary artery disease? A. Yes, that's what produces coronary insufficiency, coronary artery disease.

Q. Is there another medical term for that type of coronary artery disease? A. Arteriosclerosis is the technical name, hardening of the arteries, hardening of the coronary arteries.

Q. It's coronary— A. It's arteriosclerosis.

Q. It's coronary arteriosclerosis? A. That's right.

Q. Did the electrocardiogram tracing in your opinion confirm your tentative diagnosis that Mr. Gorey was suffering from that condition and disease? A. It did.

Q. Were you aware in October, 1953, that Mr. Gorey was in the business of building and develop-

ing tracts? A. I knew he was a carpenter in the building trade.

Q. And as I understand it, you advised him to lessen his physical activity? A. I did. [33]

Q. Did you prescribe any other treatment for him at that time? A. I gave him a prescription for nitroglycerin tablets to carry with him to be used as needed. If he developed a severe pain that lasted longer than just a few seconds, to take a nitroglycerin tablet under the tongue and I also advised him to come in in six months for another repeat electrocardiogram or before if his condition became more severe.

Q. Did Mr. Gorey consult you after October, 1953, with reference to that particular complaint or disease, namely, coronary arteriosclerosis? A. He did not.

Q. Did he consult you professionally after October, '53 for any other complaint? A. He did.

Q. Will you state the dates, please, and what the complaint was. A. In March of 1954 he had an injury at work. He sprained his knee twisting while working and we had to aspirate his joint. He had hematosis or hemorrhage in the knee joint cavity. We had to withdraw blood from his knee. He was in three or four times, discharged April 7, March 24 to April 7 for the specific condition. On August 15, 1954, was the last I saw him professionally at which time he was complaining [34] of occipital headaches. Nothing about the heart at all. I prescribed niacin tablets for relief of his headache. I have one here. If not relieved, temporarily relieved at least with these tablets, he was to consult a neurologist for a further study from a neurological standpoint, which was a study of the nervous system.

Q. That's the last time you saw him professionally? A. That's the last time I saw him, that's right."

*Cross-Examination.*

"Q. (By Mr. McManus): Dr. Kerchner, you prescribed nitroglycerin tablets for the patient. You don't know, however whether he ever took one of those pills, do you? A. That's right, I don't know that he did.

Q. And when you advised Mr. Gorey as to his physical condition, especially concerning his heart, did you tell him in lay terms or did you tell him in medical terms what was wrong with him? A. I told him lay terms. I am certain of that.

Q. And when you testify in court now, are you able to recall all of this which occurred some two or three years ago from your own memory or are you testifying only from your records? A. No. What do you mean, what part of this testimony, what I just now talked with you or with Mr. Normandin?

Q. The testimony which you have given this afternoon from the stand, is that— A. The majority—the major portion of it is from the record. As to what words I spoke to him, I am just recalling from memory the essential part, like the advice I gave him, I gave him about advising him to stop smoking and [36] reduction of exercises and so on I have recorded but a large part of the things like description, what I told him about his heart, I am recalling just from memory only.

Q. You are able to recall now at this time what you told him? A. I only because I do it to other people. I tell everybody. I have practiced the same with him as I have with others. I do not specifically

recall that I showed him pictures of the heart but I show it to people who have this trouble, explain it to him.

Q. What I am trying to get at, Doctor, is not how you treat your other patients but how you treat this particular patient, if you can remember of your own knowledge now what you told him at that time.

A. No, I can't remember exactly the words that I told him.

Q. But you do recall, do you, tell him that his condition was not too far advanced? A. That's right.

Q. Is that your testimony? A. That's right.

Q. And, as a matter of fact, you never can tell a heart patient that his condition is really bad, can you, Doctor? A. That's right. We have to be very careful because of creating a neurosthenia or a cardiac invalid. The patient [37] is sometimes so worried about their heart, they then will have to be an invalid or their family will have them sick all the time, that they actually will feel sick. So we actually have to be very careful the way we tell them about it. Sometimes we can't even tell them. It is very very bad for them to give them that. It is a hardest thing to tell a patient exactly even if we know it. The electrocardiogram cannot always show exactly how severe this trouble is. It might have been very severe at that time. It might not have been, because the record only showed that he had this trouble after he exercised. If he hadn't exercised, we wouldn't know he had it at all.

Q. And the electrocardiogram is not always correct, is it, then? A. If it is positive, yes, but negative the electrocardiogram isn't always correct.

Q. What I had reference to, Doctor, was the statement of Dr. Travis in which he said that the electrocardiogram was strongly suggestive of coronary insufficiency. Wouldn't that indicate that he wasn't positive that that was what was wrong with him? A. Well, I don't know what Dr. Windsor had in mind other than what he stated there himself that you read from. I haven't talked with him about it. Of course, you have to know laboratory work is used in conjunction with clinical [38] findings, the history of a patient taken all combined to make a diagnosis. But the electrocardiogram is a pretty good thing. It has been pretty well established through all medicine that it is a safe thing to go by in the majority of cases at least.

Q. In the majority. In other words, it could on occasion be wrong, if possible? A. It wouldn't be as pronounced. It wouldn't show up only on exercise. If he didn't have coronary artery disease, he would not have developed the findings, the segment shifts on exercise. I will have to say that was a positive finding. I don't think there is any question.

Q. You did advise another electrocardiogram?

A. Yes.

Q. After another six months? A. That's right.

Q. Did he come back for an electrocardiogram?

A. No.

Q. He did come back to see you, though, professionally, did he not? A. That's right.

Q. At that time did he make any complaint concerning his heart condition? A. No.

Q. He did come back about six months after you first [39] saw him in October? A. Let's see, October to March. That was about five months. May I say a word?

Q. Yes. A. I saw George quite a number of times. I liked him very much. He was a nice fellow. We had him do quite a bit of work around the office, small jobs in carpentry work when he was off his own job and also at the house. He always acted perfectly all right. He never complained at all about his heart hurting him while he was around us. My wife saw him at the house and I saw him at the office. So personally, I—he was a fine, honest fellow as far as I could ever tell.

Q. Apparently he did the carpenter work for you. Was that after October '53? A. Yes, yes. Oh, yes, all of this—the first time I saw him for years was October, 1953.

Q. How much after October, 1953 did he do the carpenter work for you? A. I went to the hospital myself for quite a long stay in the hospital, about six weeks in October, '55. So I never saw him after that.

Q. Yes. What I have reference to, Doctor, was he doing carpenter work for you immediately after October, 1953? A. Well, I don't—I can't tell you whether it was a month after or—but many times—I will say 1953 [40] followed '53, '54 and '55, yes. I can't tell you how many times.

Q. Now, you said on direct examination that you advised for him to cut down on his exercises? A. That's right.

Q. You mean at work or— A. At any place. You remember I said excessive exercise or over-exercises.

Q. Oh, you told him to cut down on over-exercises? A. That's right.

Q. Not normal exercise? A. No.



Q. And the work which he did for you, you considered that to be not over-exercise? A. That's right.

Q. Didn't you? A. That's right.

Q. And that wouldn't hurt him, would it? A. No. Part of his livelihood.

Q. And you have nowhere in your notes, do you, Doctor, that Mr. Gorey ever lost any time from his work on account of his heart, do you? A. No, I do not.

Q. And you don't remember him ever having told you he lost any time from that work, do you? A. No, that's right, he never mentioned his heart as far as I can recall after 1953."

Verda A. Gorey testified on redirect examination [R. 04]:

"Q. (By Mr. McManus): Mrs. Gorey, did your husband ever complain of any illness prior to his death? A. Just pains in his chest.

Q. And how long before his death did he complain of pains in his chest? A. About two or three months before.

Q. And would you explain just briefly to the jury what [82] type of carpenter work your husband did. A. Well, he was, oh, what they call a framer, putting up the structure of the house and mainly what he did at one time he was roofer but just prior to his death that's what he was doing.

Q. And, Mrs. Gorey, do you know whether or not your husband ever took any nitroglycerin tablets preceding his death? A. No, I do not.

Q. Did he take any sort of medicine before his death? A. Yes, he took some headache pills. At

one time he offered me one for my headache. That's why I happen to know that's what they were.

The Court: Did you take it?

The Witness: Yes.

Q. (By Mr. McManus): Did he ever tell you that he had any nitroglycerin tablets in the house or any other place? A. No, he didn't.

Q. And Mrs. Gorey, when were you first aware that your husband may have had heart trouble? A. At the time of his death."

## POINTS AND AUTHORITIES IN SUPPORT OF VERDICT AND JUDGMENT.

### Court Was Right in Denying Motion for Directed Verdict.

Appellant commences its attack on the verdict and judgment by claiming that *as a matter of law* the Court should have directed a verdict in appellant's favor.

Appellant on page 14 of its brief cites three cases to support its contention that a false answer in an application by a life insurance applicant will avoid a policy later issued in reliance on the application. The three cases cited are:

*San Francisco Lathing Company v. Penn Mutual Life Insurance Co.*, 144 A. C. A. 185, 300 P. 2d 715;

*Robinson v. Occidental Life Ins. Co.*, 131 Cal. App. 2d 581, 281 P. 2d 39;

*California-Western States Life Ins. Co. v. Feinstein*, 15 Cal. 2d 413, 101 P. 2d 696.

In each of the above cases cited by appellant there had been a trial to the Court, and the trial court had *found* the facts *against* the beneficiaries of the policies. In

In each case the beneficiary appealed, and asked the Appellate Court to hold that the evidence did not support the findings of the trial court which request was properly refused in each case. We have just the opposite situation in the case at bar where the jury *found* the facts *in favor* of the beneficiary, and it is the insurance company which is asking the Court to hold that *as a matter of law* the evidence did not support the jury's findings. Appellee has no quarrel with the rule of law that a false answer by a life insurance applicant in his application will avoid a policy of life insurance issued by the insurer in reliance on the application, but in the case at bar the jury evidently found from the evidence that there was no false answer. It might be noted in passing that the stipulation [R. 13] does not say that appellant relied solely on the application, but that appellant "relied upon the application, the report of the medical examiner of defendant and the report of inspection by defendant's Agent."

**Defendant Did Not Make False Answers to Any of the Questions Contained in the Application for Insurance.**

Appellant claims the answers given by the insured to questions numbered 54B and 60 of the application for insurance were false.

Question 54B was: Have you ever had any ailment or disease of: B Heart or lungs? Yes or no. The answer given is no.

There is a conflict in the evidence as to whether George E. Gorey had heart disease. He consulted Dr. Kerchner, Sr., on one occasion, and the doctor diagnosed his complaint as coronary insufficiency, not far advanced [R. 52, 50]. On the other hand there is the appellant's Exhibit

A1 which is a report by the appellant's medical examiner showing the applicant, George E. Gorey to be in good health and nothing wrong with his heart. In order for the answer to question 54B as it is phrased, to be false, there must actually have been something wrong with his heart.

**Appellant Is Estopped to Assert the Defense of  
Material Misrepresentation by the Insured.**

The testimony of appellant's district manager. Mr. Lawson W. Smith [R. 76] was that an agent of the appellant wrote all of the answers to the questions on the application, and that the only handwriting of George E. Gorey on the application was his signature. The recent case of *Boggio v. California-Western States Life Insurance Company*, 108 Cal. App. 2d 597, 239 P. 2d 144, was one in which a widow brought suit against an insurance company to collect on a policy of life insurance issued by the defendant company. The defendant resisted plaintiff's claim on the ground of alleged false statements made by the insured concerning his health. Trial was to the Court, judgment for plaintiff, and defendant appealed. On December 7, 1948, Robert Boggio signed an application for life insurance and died five months later. Defendant refused to pay and claimed the policy to be void by reason of false answers contained in the application. Two of the questions asked were:

"Have you now or have you ever had (listing specified diseases or injuries) or any other injury?" The answer given was "none." A like answer was given to another question about consultations with physicians during the ten years prior to the application. The Court said these answers were literally false because Robert had suffered a blow on the head resulting in a subarachnoid hemorrhage

in 1945 while in the Navy and was hospitalized at that time for several weeks. Defendant claimed material misrepresentation which voided the policy.

The Court found additional facts in this case as follows: The insurance was sold by Louis P. Angelino who had been an agent of the defendant for 25 years. Angelino had known the Boggio family for twelve years, had handled all of their insurance needs, and they had faith and confidence in him. Angelino was fully acquainted with Robert Boggio's hospitalization. The application was written entirely in the handwriting of Angelino, only the signature being written by Robert. Robert made full disclosure to Angelino concerning the injury when Angelino filled out the application. Angelino asked Robert what kind of discharge he had from the Navy and when informed it was honorable and not medical, he said, "Well as long as you do not have a medical discharge they don't care about all this. As long as you have an honorable discharge and not a medical discharge you can sign this application."

The defendant company relied for its defense upon three well established propositions: 1. misrepresentation as to material facts will void an insurance contract; 2. knowledge of the facts by a soliciting agent having limited authority will not relieve assured from responsibility for his own omission or misstatements in the application; and 3. when the assured has the application in his hands he may not plead ignorance of misstatements therein. In answer to these defenses the Court said the insured had stated the facts fully to Angelino, and because of the agent's misrepresentations, believed he had given answers which were truthful. He relied on the agent's superior knowledge in insurance affairs and in good faith signed

the application. "From these findings it appears that the misrepresentation upon which defendant relies occurred through the fraud or negligence of its agent and not through any of the insured." The Court further said to allow the insurer under these circumstances to place the responsibility upon the insured would be manifestly unjust and allow it to profit by its own wrong. The Court said the insurance company was estopped to assert the defense of material misrepresentation. The Court cited with approval from Cooley's Briefs on Insurance as follows:

"From an examination of the cases the following propositions may be regarded as established by the weight of authority: Where the insured, in good faith, makes truthful answers to the questions contained in the application, but his answers, owing to the fraud, mistake or negligence of the agent filling out the application, are incorrectly transcribed, the company is estopped to assert their falsity as a defense to the policy."

So in the case at bar, there were two people present when the application was signed, the deceased and appellant's agent, and only they knew what was said. The deceased could not be produced to tell his version of what took place, and the appellant failed to produce its agent. The jury could have felt through a *lack* of evidence on the part of appellant that the insured could have made a full disclosure of all facts to appellant's agent, but through the fraud, mistake or negligence on the part of appellant's agent, George E. Gorey believed he was making truthful answers to all questions. And if the jury did so believe, then appellant is estopped to assert its defenses.

**The Evidence Supports a Jury Finding That the Insured Was Not Aware of a Heart Ailment or Disease, if He in Fact Did Have a Heart Ailment or Disease.**

Dr. Kerchner testified that he made a diagnosis of coronary insufficiency. His further testimony is:

“Q. You are able to recall now at this time what you told him? A. I only because I do it to other people. I tell everybody. I have practiced the same with him as I have with others. I do not specifically recall that I showed him pictures of the heart but I show it to people who have this trouble, explain it to him.

Q. What I am trying to get at, Doctor, is not how you treat your other patients but how you treat this particular patient, if you can remember of your own knowledge now what you told him at that time. A. No, I can't remember exactly the words that I told him.

Q. But you do recall, do you, tell him that his condition was not too far advanced? A. That's right.

Q. Is that your testimony? A. That's right.

Q. And, as a matter of fact, you never can tell a heart patient that his condition is really bad, can you, Doctor? A. That's right. We have to be very careful because of creating a neurosthenia or a cardiac invalid. The patient [37] is sometimes so worried about their heart, they then will have to be an invalid or their family will have them sick all the time, that they actually will feel sick. So we actually have to be very careful the way we tell them about it. Sometimes we can't even tell them. It is very very bad for them to give them that. It is a hardest thing to tell a patient exactly even if we know it.

The electrocardiogram cannot always show exactly how severe this trouble is. It might have been very severe at that time. It might not have been, because the record only showed that he had this trouble after he exercised. If he hadn't exercised, we wouldn't know he had it at all."

From this testimony of appellant's witness the jury could have concluded that George E. Gorey was not aware he had a heart ailment or disease, if he in fact did have one.

In the case of *Stipcich v. Metropolitan Life Insurance Company*, 277 U. S. 311, 72 L. Ed. 895, 48 S. Ct. Rep. 512, which went up from the Ninth Circuit, the District Court had granted a motion for a directed verdict, but the Supreme Court reversed, and said:

"Insurance policies are traditionally contracts uberrimae fidei and a failure of the insured to disclose conditions affecting the risk, OF WHICH HE IS AWARE, makes the contract voidable at the insurer's option." (Emphasis are counsel's.)

### Cause of Death.

The evidence is far from satisfactory that George E. Gorey died from a heart condition. Dr. Kerchner did not testify as to cause of death; and the doctor who signed the death certificate (son of Dr. Kerchner) was not in Court to testify.

### Question 60 of the Application.

Question 60 of the application was:

"State names and addresses of physicians you have ever consulted and give the occasion by reference to question numbers and letters above."

The answer is—None.



This application was made at a time when the assured was actually being treated by Dr. Kerchner for a knee injury. The doctrine of estoppel applies to this question the same as it did to question 54B. Only the agent and the deceased knew what was said. The leg of the insured could have been in a cast, but the agent could have told the insured that the company was not interested in this type of sickness, and could have represented to the insured through fraud, negligence or mistake that a "none" answer would be correct and truthful.

Then as stated by the trial judge [R. 108]:

"Even without that the jury might draw an inference from all the circumstances that certainly here was a question that no one, certainly very few people in the United States at the age of 31 could answer 'No.' I just wonder how many people who can say at the age of 31 that they had never consulted a physician."

In the case of *Aetna Life Insurance Company v. Hub Hosiery Mills* (1948), 170 F. 2d 547, 74 Fed. Supp. 599, the insurance company refused to pay the beneficiary after the death of the insured on the ground the insured had stated in his application he had last consulted a physician in 1941 whereas he had consulted one in 1946 and also on the day before delivery of the policy. The Court said regarding this contention of the company:

"Insurance contracts are not to be construed with absolute literalness. They are to be construed as ordinary persons in the situation of the contracting parties would construe them."

## The Electrocardiogram.

Appellant states that the evidence is uncontradicted that the insured misrepresented and concealed from appellant's medical examiner the fact that he had undergone an electrocardiogram.

It is the claim of the appellee, however, that there is not one scintilla of evidence in the record that the insured misrepresented or concealed the fact of an electrocardiogram. The appellant did not produce Dr. Groff, its medical examiner to testify, and Dr. Groff is the only living person who has knowledge of such alleged misrepresentation and concealment. In any event whether the insured did or did not, it is immaterial here as Section 10113 of Insurance Code provides in effect that the policy together with the application is the entire contract. Section 10113 of the Insurance Code reads:

“10113. POLICY AS ENTIRE CONTRACT. Every policy of life, disability or life and disability insurance issued or delivered within this State on or after the first day of January, 1936, by any insurer doing such business within this State shall contain and be deemed to constitute the entire contract between the parties and nothing shall be incorporated therein by reference to any constitution, by laws, rules, applications or other writings, of either of the parties thereto or of any other person, unless the same are indorsed upon or attached to the policy; and all statements purporting to be made by the insured shall, in the absence of fraud, be representations and not warranties. Any waiver of the provisions of this section shall be void.”

## The Good Health of the Insured.

Appellant argues that the policy never became effective unless the insured was in actual good health at the time of the delivery of the policy.

This question was raised in the recent case of *Brubaker v. Beneficial Standard Life Insurance Company*, 130 Cal. App. 2d 340, 278 P. 2d 966. In this case the application was signed in March, 1952, and the insured died in November of the same year of cancer. The California Court said there are two rules for the construction of insurance contracts: 1, The Massachusetts rule in which actual good health is required, and 2, the rule opposed to the Massachusetts rule. The California Court said the Massachusetts rule is too harsh. The Court cited with approval language used in the case of *Chase v. Sunset Mutual Life Insurance Association*, 101 Cal. App. 525, which said:

“If . . . such representations were honestly made, and were justified by the decedent's then knowledge of his physical condition, the mere fact that the representation of the insured were proved to be unfounded by subsequent events, in the absence of fraud or deceit, would not void the policy.”

The Court said that the above views found support in two settled principles of law: 1, insurance policies are to be construed liberally in favor of the assured; and 2, courts are disinclined to construe the stipulations of a contract as conditions precedent, unless compelled by the language of the contract plainly expressed.

### The Instructions.

The instructions as given by the Court appear to be correct and in accord with the decided cases. Appellant's fourth objection to the instructions, the one dealing with expert testimony appears to be entirely without merit. There were two expert witnesses, Dr. Kerchner and the letter of Dr. Travis Windsor. It was necessary for appellant to prove at the trial that George E. Gorey had an ailment or disease of the heart in order to show that he answered question 54B falsely. If the insured did not have a heart condition in fact there could never be an issue of concealment of a heart condition.

As to the instructions requested by the appellant but refused by the Court, all of such instructions are either not a correct statement of the law or they have been otherwise included in the Court's instructions as given.

### Conclusion.

Appellee contends the evidence is ample to support the jury's verdict; that the appellant failed in its attempt to establish its defenses of misrepresentation and concealment; and that in the determination of this appeal the Court should consider all of the evidence and all inferences which can be reasonably drawn from the evidence in a light most favorable to the appellee.

Respectfully submitted,

L. E. McMANUS,

*Attorney for Appellee Verda A. Gorey.*

No. 15442

IN THE

# United States Court of Appeals

FOR THE NINTH CIRCUIT

---

THE NATIONAL LIFE AND ACCIDENT INSURANCE COMPANY,

*Appellant,*

*vs.*

VERDA A. GOREY,

*Appellee.*

---

Appeal From the United States District Court for the  
Southern District of California, Central Division.

---

APPELLANT'S REPLY BRIEF.

---

FILED

JUN - 1 1957

OVILA N. NORMANDIN, and

JOHN C. MORROW,

210 West Seventh Street,  
Los Angeles 14, California,

PAUL P. O'BRIEN, CLERK

*Attorneys for Appellant, The National Life and  
Accident Insurance Company.*



# TOPICAL INDEX

PAGE

Argument ..... 1

## I.

The uncontradicted evidence established appellant's defenses of misrepresentation and concealment. Appellant was entitled to a directed verdict and to an order setting aside the verdict and judgment..... 1

1. There is no conflict in the evidence and the evidence established without contradiction that the insured had had a heart disease before he signed the written application ..... 2

## II.

The evidence is uncontradicted that the insured knew at the time he signed the written application on April 14, 1954, that he had an ailment or disease of the heart in October, 1953 ..... 5

## III.

The evidence is uncontradicted that the cause of insured's death was coronary arteriosclerosis..... 6

## IV.

Appellant is not estopped to assert its defenses of misrepresentation or concealment..... 7

## V.

The evidence is uncontradicted that the insured misrepresented to and concealed from appellant that he had undergone an electrocardiogram ..... 12

## VI.

The defense of absence of good health when the policy was issued ..... 13

## VII.

The instructions ..... 14

Conclusion ..... 15

## TABLE OF AUTHORITIES CITED

CASES	PAGE
Aetna Life Ins. Co. v. Hub, etc., 170 F. 2d 547.....	10
Boggio v. California-Western States Life Ins. Co., 108 Cal. App. 2d 597.....	9
Brubaker v. Beneficial etc. Ins. Co., 130 Cal. App. 2d 340, 278 P. 2d 966.....	13, 14
Madsen v. Maryland Casualty Co., 168 Cal. 204, 142 Pac. 51....	7
Maggini v. West Coast Life Ins. Co., 136 Cal. App. 472, 29 P. 2d 63.....	10
McEwen v. New York Life Insurance Co., 42 Cal. App. 133, 183 Pac. 373.....	7
Parrish v. Acacia Mutual Life Ins. Co., 92 Fed. Supp. 300, aff'd 184 F. 2d 185.....	7
Pearson v. Crabtree, 70 Cal. App. 52, 232 Pac. 715.....	15
Stipcich v. Metropolitan Life Ins. Co., 277 U. S. 311, 72 L. Ed. 895, 48 S. Ct. 512.....	6

### RULES

Federal Rules of Civil Procedure, Rule 8(c) .....	8
---	---

### STATUTE

Insurance Code, Sec. 10113.....	12, 13
---------------------------------	--------

### TEXTBOOK

93 American Law Reports, pp. 374, 379, anno.....	13
--	----



No. 15442

IN THE

# United States Court of Appeals

FOR THE NINTH CIRCUIT

---

THE NATIONAL LIFE AND ACCIDENT INSURANCE COMPANY,

*Appellant,*

*vs.*

VERDA A. GOREY,

*Appellee.*

---

Appeal From the United States District Court for the Southern District of California, Central Division.

---

## APPELLANT'S REPLY BRIEF.

---

Appellant, The National Life and Accident Insurance Company, replies to appellee's brief herein as follows:

### ARGUMENT.

#### I.

**The Uncontradicted Evidence Established Appellant's Defenses of Misrepresentation and Concealment. Appellant Was Entitled to a Directed Verdict and to an Order Setting Aside the Verdict and Judgment.**

The arrangement of appellee's arguments in her brief is such as to require a consolidation herein for the purpose of replying thereto. Appellee's contentions that there was a conflict in the evidence relating to appellant's defenses of misrepresentation and concealment are answered under the above point.

**1. There Is No Conflict in the Evidence and the Evidence Establishes Without Contradiction That the Insured Had Had a Heart Disease Before He Signed the Written Application.**

Appellee, on pages 15 and 16 of her reply brief, attempts to reply to appellant's Point I(b) in its opening brief summarizing all of the evidence conclusively establishing that the insured had coronary arteriosclerosis, a heart disease, for several months prior to and at the time he signed the application. Appellee's sole contention in that regard is that the medical examiners report [Ex. A-1] showed Mr. Gorey "to be in good health and nothing wrong with his heart." The report merely shows that the medical examiner examined the insured on April 20, 1954, and that in regard to the insured's heart the examiner found "the heart's action uniform, free and steady, and the sounds and rhythm regular and normal" (answer 8D) and that in answer to question 8E "Does physical examination reveal anything abnormal in the condition or functions of the heart or blood vessels?" the examiner's answer was "No." We submit that the report does not show that there was nothing wrong with the insured's heart but merely shows the obvious fact that the examiner, on April 20, 1954, found the insured's heart action to be "free and steady, etc." and nothing "abnormal in the conditions or functions of the heart or blood vessels" by a physical examination of the insured's chest.

Furthermore, appellee makes this contention with respect to her claim that the insured's answers in the application regarding heart disease were not false, viz, on the question of false representation and concealment. Question 54B in the application was as to whether the insured

had “ever had any ailment or disease of the heart,” referring to any time prior to the date of the application (April 14, 1954). Even if it were to be assumed, for argument, that the failure of the medical examiner to find any indication of heart disease on April 20, 1954 is evidence that he then had no heart disease (which is not conceded), that circumstance is not evidence that the insured had never had any ailment or disease of the heart.

Appellant refers to its summary of the evidence on this question under Point I(b), appellant’s opening brief (pp. 17-21), showing that the evidence was uncontradicted that the insured *had* an ailment or disease of the heart in October, 1953, some five months before the date of the application and the medical examination by appellant’s medical examiner. We do not repeat the summary but invite the Court’s attention to the record if there be any question on this matter. We point out, however, that appellee in her brief quotes a portion of Dr. Kerchner’s testimony only. His diagnosis of the insured’s condition in October, 1953 was not just “coronary insufficiency” as appellee implies in her brief, page 15. The testimony was that the doctor first “made a tentative diagnosis of coronary insufficiency, coronary heart disease” [R. 52], and that later, after consulting with Dr. Windsor, he made a final diagnosis of “coronary heart disease” [R. 55] “coronary artery disease—coronary arteriosclerosis” [R. 56]. And the insured did not consult Dr. Kerchner, Sr. on but one occasion as appellee states (Br. p. 15) but rather on three occasions with reference to his heart condition [R. 49].

Another matter should be noted in connection with this point. The medical examiner's report [Ex. A-1], which was on the reverse side of the written application [Ex. A], shows that the medical examiner verified the insured's answers to Part IV of the application. Part IV of the application, question 54B, asks whether the insured had ever had any ailment or disease of the heart, to which the insured answered "No," and question 60 asks for the insured's statement of the names and addresses of physicians the insured had ever consulted, to which the insured answered "None." By stating in the report that he had verified these answers the medical examiner thereby reported that he had asked the insured as to such questions and answers given in the application and that the insured gave the same answers. Since the medical examiner's report, question and answer 8F, also shows that the insured reported to the examiner that he had never undergone an electrocardiogram, it is clear that the insured misrepresented his medical history to the medical examiner, making it difficult or impossible for the examiner to make any proper diagnosis as to the condition of the insured's heart. Dr. Kerchner's testimony shows that it is necessary for a physician to have the correct medical history as well as an electrocardiogram in order to make an accurate diagnosis of coronary heart disease [R. 61]. This is another reason why appellee may not rely on the medical examiner's report as evidence that the insured had never had a heart disease.

II.

**The Evidence Is Uncontradicted That the Insured Knew at the Time He Signed the Written Application on April 14, 1954, That He Had an Ailment or Disease of the Heart in October, 1953.**

Appellee, at pages 19-20 of her brief, contends that there is evidence to support a finding that the insured was not aware that he had a heart ailment or disease, quoting a portion of Dr. Kerchner's testimony. While Dr. Kerchner testified that he could not remember the exact words by which he told the insured that he had a heart disease in October, 1953 and that he told the insured that his condition was not too far advanced [R. 60], there is no question whatsoever that the doctor in October, 1953 told the insured that he had coronary heart disease—coronary artery disease. Dr. Kerchner testified as follows [R. 59]:

“Q. And when you advised Mr. Gorey as to his physical condition, especially concerning his heart, did you tell him in lay terms or did you tell him in medical terms what was wrong with him? A. I told him in lay terms. I am certain of that.”

Dr. Kerchner also testified that in October, 1953 he advised the insured “to stop smoking and reduction of exercise” [R. 59], and that “. . . I explained to him that he did have this trouble and prescribed for him a regime of lighter work, less forceful exercise, discontinuing smoking and overeating perhaps, anything that might produce increased rate of the heart which would likely bring on the pain that he experienced . . .” [R. 55]; also, that he gave the insured a prescription for nitroglycerin tablets to take for the pain and advised him to come in for another electrocardiogram in six months

[R. 56-57]. There is just no evidence whatsoever showing or tending to show that the insured did not know in April, 1954 that he had coronary heart disease in October, 1953, nor is there any evidence from which such an inference could be drawn.

Appellee in her brief, page 20, quotes from *Stipcich v. Metropolitan Life Ins. Co.*, 277 U. S. 311, 72 L. Ed. 895, 48 S. Ct. Rep. 512, on the point that an applicant for insurance is charged only with disclosing to the insurer conditions affecting the risk of which he is aware, and of course this is not disputed. In passing it will be noted that in the *Stipcich* case the Supreme Court merely held that evidence offered by the beneficiary to the effect that the insured communicated to the agent for the insurer the fact that after making the application the insured consulted two physicians regarding an ulcer should have been received by the trial court. The Supreme Court also stated that if the evidence had shown that the insured had made a positive misrepresentation regarding a visit to a physician *before* applying for insurance the court would have affirmed the circuit and trial court's judgment for the insurer.

### III.

#### The Evidence Is Uncontradicted That the Cause of Insured's Death Was Coronary Arteriosclerosis.

In its opening brief, pages 25-26, appellant cited the uncontradicted evidence showing that the insured died of coronary arteriosclerosis with reference to its separate defense that the insured was not in good health when the policy was delivered to him. While pertinent to that separate defense, the cause of the insured's death is not a

necessary element of the separate defenses of misrepresentation and concealment as to medical history in the written application or of misrepresentation and concealment in the application as to prior consultations with physicians. The law is clear that it is immaterial if the insured's condition misrepresented to or concealed from the insurer by the insured had no connection with the insured's death or did not shorten his life. The misrepresentation or concealment avoids the policy regardless. *McEwen v. New York Life Insurance Co.*, 42 Cal. App. 133, 183 Pac. 373; *Madsen v. Maryland Casualty Co.*, 168 Cal. 204, 142 Pac. 51; *Parrish v. Acacia Mutual Life Ins. Co.*, 92 Fed. Supp. 300, *aff'd* 184 F. 2d 185 (9th Cir. 1950). Of course where the evidence does show, as it does here, that the insured did die of the very condition he misrepresented or concealed, the materiality of the misrepresentation or concealment becomes self evident, although such proof be unnecessary.

#### IV.

#### **Appellant Is Not Estopped to Assert Its Defenses of Misrepresentation or Concealment.**

There was no question or issue of estoppel raised in the pleadings of either party, nor was it mentioned in pre-trial or in any pre-trial stipulations or other pre-trial papers. No instructions were requested or given on any such question or issue and there was no evidence offered or received which could tend to establish any estoppel. It was certainly not incumbent on the appellant to raise or present any such issue or to present any evidence to combat any such mythical matter. On the contrary it was the appellee's burden to raise such an issue by pleading

and by evidence in the trial court if she desired to present any such point and she may not, under these circumstances, properly make any such contention on appeal (Rule 8(c), F.R.C.P.).

Even if such an issue had been raised, there is no evidence whatsoever which tends to show or from which an inference may be drawn that the agent who took the insured's written application for insurance was given any information by the insured relative to his medical history or any other matter other than the insured's answers given by him in the written application. Nor is there any evidence whatsoever showing any mistake or that the agent was negligent or that he misled the insured or in any way represented to him that he was not required to truthfully answer all questions set forth in the written application.

In support of her claim of estoppel the appellee relies on the evidence to the effect that it was the procedure of appellant for the agent taking an application for insurance to ask the questions in the application of the insured and for the agent to write down on the application form the answers given by the insured, and for the agent then to request the applicant to review the questions answered and if found correct, to sign the application, and that the answers of the insured on the written application are in the agent's handwriting [R. 76-77]. From this evidence and from the fact that the agent was not called as a witness by appellant the appellee argues that the jury "could have felt" that through fraud, mistake or negligence of the agent that the insured believed he was making truthful answers to all questions (Appellee's Br., p. 18).



As above pointed out, no burden was cast on the appellant to present any such issue. Since appellee did not, it certainly was not incumbent upon appellant to call Mr. Haws, the agent who took the insured's application. Agent Haws' employment with the appellant terminated in November, 1954 and his address in Utah was supplied to appellee in June, 1956, by the answers to interrogatories by Mr. Stevenson, appellant's president [R. 97]. Appellee made no effort to obtain or present any testimony of former agent Haws and since she had the burden on any such matter she cannot on appeal successfully contend that the appellant had any duty to present testimony by Haws.

Appellee refers to the case of *Boggio v. California-Western States Life Ins. Co.*, 108 Cal. App. 2d 597, 239 P. 2d 144, but that case is inapplicable here since the facts there were entirely different. In the *Boggio* case the evidence showed, and the trial court found, that the insurer's agent who took the insured's application for insurance was given a *truthful* statement of the facts as to the insured's prior medical history by the insured and that the agent falsely represented to the insured that the questions in the application did not require or call for information as to certain injuries the insured had received in the service. The Court then also found that the agent's misrepresentations were believed and relied upon by the insured in failing to include the information in his answers on the application, and that the insured acted reasonably in doing so. That was an entirely different situation from the case at bar. Here there was no evidence whatsoever to establish any such acts by the agent Haws, nor

may any such acts be inferred from the evidence. In the absence of such evidence it must be presumed that the agent acted in good faith. (*Maggini v. West Coast Life Ins. Co.*, 136 Cal. App. 472, 476, 29 P. 2d 63.)

In her brief, pages 20-21, appellee attempts to escape from the effect of the insured's false representation and concealment as to his prior consultations with Dr. Kerchner for diagnosis and treatment of his coronary heart disease by making the bald and unsupported statement that agent Haws "could have told the insured that the company was not interested in this type of sickness, and could have represented to the insured through fraud, negligence or mistake that a 'none' answer would be correct and truthful." This contention has absolutely no basis or merit, should require no answer, but in any event is answered by appellant's comments hereinabove made. Appellee's quotation (Br. p. 21) of a portion of the trial judge's remarks or colloquy with counsel, on argument for motion for a directed verdict, has no place in a brief on appeal. In any event appellant urges that the trial judge's quoted remarks were erroneous then and are no more meritorious now than they were when made.

Appellee cites as authority the case of *Aetna Life Ins. Co. v. Hub, etc.*, 170 F. 2d 547. The facts of that case do not remotely resemble those of this case. That case involved Massachusetts law, which differs from California law on the point. The Massachusetts law is that a misrepresentation as to prior consultation with a physician and as to prior medical history does not avoid a policy issued in reliance thereon unless made with actual intent to deceive or unless it increased the risk of loss. In that

case the facts relied on by the insurer to cancel the policy were that the insured had had an attack of "chills" for which he had consulted a physician *after* making application for the policy and before it was issued, and that the insured had not reported such consultation to the insurer. It appeared that the physician had made a diagnosis of "no disease" and that the insured was discharged as "well"; also, that the insurer conceded that representations as to past health did not cover a temporary or minor ailment such as a cold. The court there stated that assuming that a failure to report the consultation with the doctor for the chill between the date of application and delivery of the policy was tantamount to a false statement in the application, it could not be said that it amounted to a misrepresentation of a material fact made with actual intent to deceive or to a misrepresentation of a matter increasing the risk of loss. In the case at bar there was uncontradicted evidence of a misrepresentation and concealment in the written application of the three previous consultations by Mr. Gorey with Dr. Kerchner for severe pain in the heart region, the diagnosis by the doctor of coronary heart disease—coronary arteriosclerosis, an extremely dangerous and deadly disease, and of the doctor's advice to the insured that he had the heart disease. As pointed out in appellant's opening brief the misrepresentations and concealments were unquestionably material to the risk. With such evidence in the record the beneficiary cannot escape the consequences of the insured's deception by attempting to raise a new and false issue of estoppel on appeal or by attempting to becloud the issues with other inapplicable matters.

V.

**The Evidence Is Uncontradicted That the Insured Misrepresented to and Concealed From Appellant That He Had Undergone an Electrocardiogram.**

Appellant, in its opening brief, pages 21-22, pointed out the uncontradicted evidence establishing its separate and additional defense based on the insured's misrepresentation and concealment of the prior electrocardiogram. This defense is distinct from and is not a necessary element of its separate defenses of (a) misrepresentation and concealment as to the prior medical history of heart disease, or (b) misrepresentation and concealment as to the previous consultations with Dr. Kerchner. Nevertheless, the defense based on the electrocardiogram is sufficient in itself to avoid the policy. Since appellee stipulated that it was an unadmitted fact not to be contested that in October, 1953 the insured was examined by Dr. Kerchner and that the doctor had him undergo an electrocardiogram [R. 15-16], and since Dr. Kerchner's testimony stands uncontradicted that the insured did have an electrocardiogram taken in October, 1953, and since the medical examiner's report is in evidence without objection and speaks for itself, there was no occasion for appellant to call the medical examiner. It must be presumed that he acted in good faith.

As to the applicability here of Insurance Code, Section 10113, cited by appellee, it is true that a copy of the medical examiner's report was not attached to the policy when it was delivered to the insured. It is admitted that a photostatic copy of the application itself was attached to the policy when delivered, so that Section 10113 can have no bearing on the misrepresentations made in the

application. If the misrepresentation and concealment respecting the electrocardiogram did not amount to fraud appellee would no doubt be correct in maintaining that the unattached medical examiner's report could not avoid the policy. However, it will be noted that Section 10113 merely states that an unattached writing is not part of the contract. Failure to attach a writing to the policy does not prohibit the unattached writing from being used as competent evidence of fraud inducing the issuance of a policy and the decided weight of authority where similar statutes were construed makes such a distinction. (Ann. 93 A. L. R. 374, at p. 379.) Certainly there is strong evidence of fraud in this case. Furthermore, appellee admitted that appellant relied upon the medical examiner's report in issuing and delivering the policy [R. 15].

## VI.

### **The Defense of Absence of Good Health When the Policy Was Issued.**

In its opening brief, pages 25-26, the appellant summarized the uncontradicted evidence that the insured was not in "good health" when the policy was issued and delivered, which was a distinct and separate defense. Appellee cites *Brubaker v. Beneficial etc. Ins. Co.*, 130 Cal. App. 2d 340, 278 P. 2d 966, as authority that California has adopted a more liberal rule than Massachusetts with respect to the effect of such policy provisions. While that appears to be the case, the *Brubaker* case does not govern the facts of this case. There it appeared, and the trial court found, that the insured's statements in the application that he was in good health were made in good faith so far as he then knew. Also, the

medical examiner for the company in that case was also the insured's personal physician and had previously examined him for a complaint and had diagnosed his condition as acute gastroenteritis. When the doctor again examined him for the insurance he reported to the insurer that the applicant was "quite healthy." After the policy was issued an operation disclosed cancer. In *Brubaker*, the court expressly distinguished the fraud, deceit and misrepresentation cases and held that such cases were not controlling under the facts there, as the insured had acted in good faith and without any knowledge of the cancerous condition.

Here the evidence of misrepresentation, concealment and deceit by the insured in agreeing and representing in the written application that he was in good health is overwhelming and not contradicted. Beyond question he was not in good health when he executed the application or when the policy was delivered to him, and he knew it.

## VII.

### The Instructions.

Appellee passes off appellant's specifications of error in regard to the instructions given and refused, by the bald and unsupported statement that the objections are without merit. If appellant's objections to the instructions are without merit it would seem that the appellee might find some authority to support her statement. Appellee cites no such authority because there is none. Appellee does refer to the instruction covered by appellant's specification of error number (4). In addition to appellant's comments in its opening brief on this subject, it should be noted that even if it were to be conceded that Dr. Kerch-

ner gave some expert testimony or that Dr. Windsor's report were to be considered in that category, the instruction in question was erroneous. The California law does not appear to support such an instruction even where there is expert testimony. Where laymen have no knowledge of the subject they are not at liberty to reject expert opinion testimony in a civil case. See *Pearson v. Crabtree*, 70 Cal. App. 52, 232 Pac. 715, where an instruction to the effect that the jury might entirely disregard expert testimony was disapproved and judgment reversed on that ground.

### Conclusion.

Appellant is entitled to reversal of the judgment and direction for entry of judgment in its favor since there was insufficient evidence to entitle the case to be submitted to the jury as a matter of law. A case cannot be submitted to a jury upon speculation. Furthermore, prejudicial error was committed as to the specified instructions objected to and as to those requested but refused.

Respectfully submitted,

OVILA N. NORMANDIN and

JOHN C. MORROW,

By JOHN C. MORROW,

*Attorneys for Appellant, The National Life  
and Accident Insurance Company.*





No. 15442

IN THE

# United States Court of Appeals

FOR THE NINTH CIRCUIT

---

THE NATIONAL LIFE AND ACCIDENT INSURANCE COM-  
PANY,

*Appellant,*

*vs.*

VERDA A. GOREY,

*Appellee.*

---

PETITION FOR REHEARING.

---

L. E. McMANUS,

8339 Second Street,  
Downey, California,

*Attorney for Appellee.*

**FILED**

DEC 3 1957

PAUL P. GORDON, CLERK



## TOPICAL INDEX

	PAGE
Trial court was right in refusing to direct the verdict.....	1
There was an issue of fact.....	3
The instructions on opinion evidence.....	5
Conclusion .....	6

## TABLE OF AUTHORITIES CITED

CASES	PAGE
California Western States Life Insurance Company v. Feinstein, 15 Cal. 2d 413, 101 P. 2d 696.....	5
Cohen v. Penn Mutual Life Insurance Company, 48 Cal. 2d 720, 312 P. 2d 241.....	3, 4
Negvesky v. Alston, 312 P. 2d 728.....	2
Ritchie v. Long Beach Community Hospital Association, 139 Cal. App. 688, 34 P. 2d 771.....	2
Sokolow v. City of Hope. 41 Cal. 2d 668, 262 P. 2d 841.....	2

No. 15442

IN THE

# United States Court of Appeals

FOR THE NINTH CIRCUIT

---

THE NATIONAL LIFE AND ACCIDENT INSURANCE COM-  
PANY,

*Appellant,*

*vs.*

VERDA A. GOREY,

*Appellee.*

---

## PETITION FOR REHEARING.

---

Appellee respectfully moves the Court for a rehearing of this case for the following reasons.

### **Trial Court Was Right in Refusing to Direct the Verdict.**

The Trial Court was correct in refusing to direct a verdict in favor of the defendant. A motion for a directed verdict for a defendant should be granted only when, disregarding conflicting evidence, and giving to the plaintiff's evidence all the value to which it is legally entitled, and indulging in every legitimate inference which may be drawn from the evidence, the result is a determination that there is not sufficient substantiality to support a

plaintiff's verdict. A motion for a defendant should be granted only when there is a complete defense by uncontradicted evidence.

*Ritchie v. Long Beach Community Hospital Association*, 139 Cal. App. 688, 34 P. 2d 771;

*Sokolow v. City of Hope*, 41 Cal. 2d 668, 262 P. 2d 841.

In the recent California case of *Negvesky v. Alston* reported in 312 P. 2d 728, the insurance company sought to rescind a policy of insurance upon the ground the evidence showed *conclusively* the policy was secured through fraud and misrepresentation. The trier of the facts found against the insurance company, and it appealed. The Court in its opinion stated:

“But this was a question of fact for the trial court to determine. It needs no citation of authority to support the fundamental rule of California law that if there is any substantial evidence in the record to support the trial court's finding contrary to the insurance company's contention, it is not within the power of this reviewing court to disturb it.”

And again,

“While it is of course true that contrary deductions could have been made from the evidence, such deductions under our law are for the determination of the trier of the facts. This court's power and function ends when it finds any substantial evidence in the record that will support a finding by the trial court. *Primm v. Primm*, 46 Cal. 2d 690, 693, 299 P. 2d 231.”

### There Was an Issue of Fact.

Question 54 was, "Have you ever had any ailment or disease of Heart or lungs"? The answer given was "no." In answering the question, all that was required of the applicant was that he give an honest answer. It is not required by law or by the terms of the policy that he give a warranty as to the correctness of his answer. Appellee concedes there was evidence applicant had a heart disease or ailment, but it is contended there was evidence also to the contrary in (1) Dr. Groff's examination and (2) the evidence that he worked at a strenuous trade every day until the date of death. If he did not *in fact* have a heart disease or ailment, the question was answered corrected regardless of whether he had consulted with Dr. Kerchner and regardless of Dr. Kerchner's opinion. There was also a lack of evidence in that no autopsy was performed. The question asked was not whether he had ever had a diagnosis of heart disease made by a doctor, but rather had he in fact ever had a heart disease or ailment. It was properly a question for the trier of the facts.

The court's opinion appears to rest upon the decision made by the California Supreme Court in the case of *Cohen v. Penn Mutual Life Insurance Company*, 48 Cal. 2d 720, 312 P. 2d 241. That decision was made by a 4 to 3 vote of the Court with a very strong dissenting opinion. While the case is as much the law of California as though the Court had unanimously reversed, yet it demonstrates that had the facts of the case been a little less compelling than they were, the case would not have been reversed. In the majority opinion great stress is laid on the fact that the deceased was a doctor, and the

case is bottomed on such fact. But this Court says at page 7 of its opinion, “but he knew that he had pain in the region of the heart, that his heart had been examined, that he had been given medicine for pain in or about the heart.” Answering each part of the quoted portion of the opinion, (1) The evidence showed that on one day in this man’s life he had pain in the region of his heart. He consulted the doctor on two occasions thereafter at the doctor’s request for the purpose of making tests. It is not known whether he still had the pain on the latter visit or not. In any event, a pain in the region of his heart does not necessarily indicate a heart disease; (2) it is true he knew his heart had been examined, but that fact does not mean he knew he had heart disease; (3) it is true he had been given a prescription for medicine for pain in or about the heart, but the evidence indicates he was not seriously enough impressed with a heart disease to have the prescription filled [R. 104].

In the *Cohen* case the Court says: “Here the deceased was himself a doctor, he knew his medical history in regard to his heart condition. . . .” But in this case he was not a doctor, and his consulting physician minimized a patient’s heart condition in making a report to the patient. “Sometimes we can’t even tell them” [R. 60]. Further the doctor’s office records indicate the deceased may not have recognized his true condition.

In the *Cohen* case the applicant was asked several specific questions concerning medical treatment and diagnosis, while in this case there is only a general question—do you have a disease or ailment of the heart—clearly calling for the applicant’s opinion.



The Court in its opinion cites the case of *California Western States Life Insurance Company v. Feinstein*, 15 Cal. 2d 413, 101 P. 2d 696. In an application for reinstatement the insured stated in this case that he had no "injury, deformity or symptoms of sickness" nor had he "consulted a physician for any ailments since said policy of insurance was issued." The application was made on December 30, 1935. It was shown by uncontradicted evidence at the trial that the insured had consulted Dr. Swezey on 26 occasions, the last of which was on October 16, 1935 in addition to consulting another doctor. The trial court found for the insurance company. On appeal the California Supreme Court said, page 419:

"Under those circumstances, it is a well established rule that on a review of the evidence, together with the inferences which could have been drawn therefrom, the conclusion to be reached was solely for the trial court, who saw the witnesses and heard them testify, and that the findings made thereon by the trial court may not be disturbed."

Had the trial court's findings been in favor of the insured in this case, the California court would not have disturbed the findings, and a recovery could have been had by the insured regardless of the visits to the doctor. It was a question of fact for the trial court, not a question of law.

### **The Instructions on Opinion Evidence.**

The Court says the instruction on opinion evidence was error. Dr. Kerchner testified not only as to facts as stated by the Court but also gave his opinion as to the deceased heart condition. The doctor's opinion together with the opinion of Dr. Travis Windsor was the only

evidence the appellant had to prove the falsity (if it was false) of question 54. It was essential to the appellant's case, that it prove a heart disease. This proof was made through the doctor's opinion.

### Conclusion.

There was a question of fact in this case properly submitted to the jury which this Court should not have resolved into a question of law.

Respectfully submitted,

L. E. McMANUS,

*Attorney for Appellee.*

---

### Certificate of Counsel.

I, L. E. McManus, counsel for Petitioner, in the above entitled action, hereby certify that the foregoing petition for rehearing of this cause is presented in good faith and not for delay, and in my opinion is well founded in law and in fact, and proper to be filed herein.

L. E. McMANUS,

*Attorney for Petitioner.*

No. 15443

IN THE

# United States Court of Appeals

FOR THE NINTH CIRCUIT

---

ROBERT LEE RAMSEY,

*Appellant,*

*vs.*

UNITED STATES OF AMERICA,

*Appellee.*

---

## APPELLEE'S BRIEF.

---

LAUGHLIN E. WATERS,  
*United States Attorney,*

LOUIS LEE ABBOTT,  
*Assistant United States Attorney,  
Chief, Criminal Division,*

LLOYD F. DUNN,  
*Assistant United States Attorney,  
Assistant Chief, Criminal Division,*

600 Federal Building,  
Los Angeles 12, California,  
*Attorneys for Appellee.*

**FILED**

**MAY 13 1957**

**PAUL P. O'BRIEN, CLERK**



## TOPICAL INDEX

PAGE

### I.

Statement of jurisdiction..... 1

### II.

Statement of the case..... 2

A. Procedural sequence giving rise to this appeal..... 2

B. Summary of operational facts..... 2

### III.

Argument ..... 3

A. The District Court had jurisdiction of the subject matter 3

B. The court had jurisdiction of appellant's person..... 4

C. Appellant is without standing to raise the question of  
comity ..... 5

### IV.

Conclusion ..... 7

## TABLE OF AUTHORITIES CITED

CASES	PAGE
Chapman v. Scott, 10 F. 2d 156, aff'd 10 F. 2d 690, cert. den. 270 U. S. 657, 70 L. Ed. 784, 46 S. Ct. 354.....	5
Ford v. United States, 273 U. S. 593, 71 L. Ed. 793, 47 S. Ct. 531 .....	5
Nelson v. United States, 217 F. 2d 469.....	3
Pon v. United States, 168 F. 2d 373.....	5
Rosenthal v. Hunter, 164 F. 2d 949.....	6
Stamphill v. Johnston, 136 F. 2d 291, cert. den. 320 U. S. 766, 88 L. Ed. 457, 64 S. Ct. 70.....	4, 5, 6
United States v. Rosenberg, 195 F. 2d 583, cert. den. 344 U. S. 838, 97 L. Ed. 652, 73 S. Ct. 20.....	5

### RULES

Federal Rules of Criminal Procedure, Rule 12(b)(2).....	5
Federal Rules of Criminal Procedure, Rule 18.....	4
Federal Rules of Criminal Procedure, Rule 37.....	1
Federal Rules of Criminal Procedure, Rule 39.....	1

### STATUTES

United States Code, Title 18, Sec. 2114.....	1, 2, 3
United States Code, Title 18, Sec. 3231 .....	1, 3
United States Code, Title 28, Sec. 1291.....	1
United States Code, Title 28, Sec. 2255 .....	1, 2

No. 15443

IN THE

# United States Court of Appeals

FOR THE NINTH CIRCUIT

---

ROBERT LEE RAMSEY,

*Appellant,*

*vs.*

UNITED STATES OF AMERICA,

*Appellee.*

---

## APPELLEE'S BRIEF.

---

### I.

#### Statement of Jurisdiction.

This is an appeal from an Order of the United States District Court for the Southern District of California denying the Motion of appellant to modify, vacate or set aside the sentence and judgment of that Court entered March 9, 1954, committing appellant to the custody of the Attorney General for seven and one-half years for violation of Section 2114, Title 18, United States Code.

Jurisdiction of the District Court is founded upon Section 3231, Title 18, United States Code. Petition to vacate the original judgment was submitted by appellant under the provisions of Section 2255, Title 28, United States Code. Jurisdiction of the Court of Appeals to entertain this matter may be found under the provisions of Section 1291, Title 28, United States Code, and Rules 37 and 39 of the Federal Rules of Criminal Procedure.

## II.

### Statement of the Case.

#### A. Procedural Sequence Giving Rise to This Appeal.

On March 9, 1954, Robert Lee Ramsey and his co-defendant, Robert J. Nelson (not represented on this appeal), parole violators from the State of California, were convicted, despite pleas of "not guilty," for violating Title 18, United States Code, Section 2114, and were committed by the Honorable Ben Harrison to the custody of the Attorney General for a period of seven and one-half years. Subsequently, on the 25th of October, 1956, Robert L. Ramsey presented to the Honorable Ben Harrison, Judge of the United States District Court, Southern District of California, a Motion under Title 28, Section 2255, United States Code, urging the Court to vacate the judgment. The ground petitioner alleged was absence of jurisdiction to impose sentence. Judge Harrison, on October 31, 1956, entered an Order denying petitioner's Motion. This Order was supplemented by Findings of Fact, Conclusions of Law and Judgment of Denial entered by His Honor on November 14, 1956. Petitioner Ramsey then filed, on the 23rd of November, 1956, his Notice of Appeal, and moved to proceed *in forma pauperis*. This latter Motion was honored by Judge Harrison.

#### B. Summary of Operational Facts.

Appellant, in the month of March, 1950, was convicted in a California State court for the crime of robbery. He was sentenced to San Quentin for a term of from five years to life. After serving more than three years, appellant was paroled under the supervision of the State of California Parole authorities. On February 5, 1954,



defendant was again arrested by California State authorities. On February 9, 1954, he was taken into the custody of federal authorities from the State of California. Thereafter, on March 9, 1954, he was found guilty by a jury of the crime of robbery of a post office, in violation of Section 2114, Title 18, United States Code, and was thereupon sentenced to the custody of the Attorney General for seven and one-half years. Thereafter, the State of California placed a detainer against appellant as a parole violator.

### III.

#### Argument.

#### A. The District Court Had Jurisdiction of the Subject Matter.

The gist of appellant's position seems to be that he was a parole violator of the State of California at the time he committed the federal crime, and that this conferred upon him some sort of immunity from federal prosecution. He concludes that the federal District Court did not have jurisdiction to impose the sentence.

Appellant was tried by the Honorable Ben Harrison, United States District Judge for the Southern District of California, after his plea of not guilty for alleged violation of Section 2114, Title 18, United States Code [Clk. Tr. pp. 6, 7], a post office robbery occurring in Los Angeles County, California, on January 13, 1954. The jury returned a guilty verdict as to him and a co-defendant, Robert J. Nelson (see *Nelson v. United States*, 217 F. 2d 469 (9 Cir., 1955)).

District Courts of the United States have original and exclusive jurisdiction of offenses against the laws of the United States. Section 3231, Title 18, United States Code.

Prosecution of federal crimes shall be had in the District in which the offense was committed. Rule 18, Federal Rules of Criminal Procedure.

Thus the trial court had jurisdiction of the subject matter of this crime committed within its District.

**B. The Court Had Jurisdiction of Appellant's Person.**

Appellant came into federal custody February 9, 1954 [Clk. Tr. p. 14]. He pleaded not guilty to the federal charge [Clk. Tr. p. 7]. He was convicted by a jury and sentenced on March 9, 1954, to seven and one-half years in the custody of the Attorney General [Clk. Tr. p. 14]. No indication is given us at any point that the appellant or the State of California objected to the District Court's exercise of jurisdiction over appellant's person.

This Honorable Court has treated of a similar, but, on its facts, a more aggravated, case in the following language:

“However, in this case the state authorities did in fact surrender the appellant to the federal authorities and thus in effect gave the federal court jurisdiction to try the appellant and to render judgment of imprisonment against him and to execute that judgment. The personal presence of a defendant before a District Court gives that court complete jurisdiction over him, regardless of how his presence was secured, . . . .”

*Stamphill v. Johnston*, 136 F. 2d 291, 292 (9 Cir., 1943), cert. den. 320 U. S. 766, 88 L. Ed. 457, 64 S. Ct. 70.

Objection to jurisdiction of the person may be waived by defendant. A failure to challenge jurisdiction of the

person on appearance is equivalent to consent. *Chapman v. Scott*, 10 F. 2d 156 (D. C. Conn., 1925), *affd.* 10 F. 2d 690 (2 Cir., 1926), *cert. den.* 270 U. S. 657, 70 L. Ed. 784, 46 S. Ct. 354; *Ford v. United States*, 273 U. S. 593-606, 71 L. Ed. 793, 47 S. Ct. 531.

By going to trial on a plea of not guilty without objection to the jurisdiction of the court over his person, a defendant waives such objection even under Rule 12(b)(2) of the Federal Rules of Criminal Procedure. *Pon v. United States*, 168 F. 2d 373 (1 Cir., 1948); *United States v. Rosenberg*, 195 F. 2d 583 (2 Cir., 1952), *cert. den.* 344 U. S. 838, 97 L. Ed. 652, 73 S. Ct. 20.

“It is clear that federal authorities had actual possession of defendant during his trial in the federal court. Jurisdiction resulted from that possession and it follows that any question concerning the rightfulness of what was done in the exercise of that jurisdiction is merely a question of comity.”

*Stamphill v. Johnston, supra*, at p. 292.

### **C. Appellant Is Without Standing to Raise the Question of Comity.**

The theory of comity, raised in appellant's Brief, is not applicable to the instant situation since there is no evidence or indication that California authorities have asserted any claim inconsistent with the action of federal authorities. On the contrary, it appears that State authorities surrendered appellant to the United States for prosecution, and have placed a detainer to obtain custody upon completion of his federal sentence, thereby impliedly assenting thereto.

“Here, there was no showing that the California officials, with authority in the premises, did not consent to the United States taking petitioner into custody and trying, sentencing, and imprisoning him for the Federal offenses. Since public officials are presumed not to act unlawfully, it must be presumed, in the absence of a showing to the contrary, that California voluntarily surrendered custody of the petitioner to the federal authorities. Moreover, the fact that the California authorities merely filed a detainer request and did not demand surrender of petitioner for violation of his parole until the expiration of the Federal sentences indicates that California consented to Federal custody.”

*Rosenthal v. Hunter*, 164 F. 2d 949, 950 (10 Cir., 1947).

Appellant himself has no standing to raise the comity question, as is indicated by this Honorable Court in the following language:

“As pointed out by the Supreme Court in *Ponzi v. Fessenden*, 258 U. S. 254, 42 S. Ct. 309, 66 L. Ed. 607, 22 A. L. R. 879, *supra*, the arrangement made between the two sovereigns, the state and federal governments, does not concern the defendant who has violated the laws of each sovereignty and he cannot in his own right demand priority for the judgment of either. See to the same effect, *Banks v. O’Grady*, 8 Cir., 113 F. 2d 926.”

*Stamphill v. Johnston*, *supra*, at 292.

IV.

**Conclusion.**

Appellee respectfully submits to this Honorable Court:

1. That the District Court had jurisdiction over both subject matter and appellant's person;
2. That California impliedly agreed to appellant's present incarceration and has indicated its consent thereto by filing a detainer to be effective upon his release from federal custody;
3. That there is no conflict between the federal and state authorities which would involve the principle of comity;
4. That appellant's state parole status does not insulate him from federal prosecution for crimes committed while on parole;
5. That appellant's appeal is completely without merit and should be denied, and that the order appealed from should be affirmed.

Respectfully submitted,

LAUGHLIN E. WATERS,  
*United States Attorney,*

LOUIS LEE ABBOTT,  
*Assistant United States Attorney,  
Chief, Criminal Division,*

LLOYD F. DUNN,  
*Assistant United States Attorney,  
Assistant Chief, Criminal Division,  
Attorneys for Appellee.*



No. 15447

---

---

United States  
Court of Appeals  
For the Ninth Circuit

---

GRACE M. POWELL, Executrix of the Estate of  
O. E. Powell, Deceased,

Appellant,

vs.

RALPH C. GRANQUIST, District Director of  
Internal Revenue,

Appellee.

---

Transcript of Record

---

Appeal from the United States District Court for the  
District of Oregon

FILE

JUN 11 1957

PAUL P. O'BRIEN, C





No. 15447

---

United States  
Court of Appeals  
For the Ninth Circuit

---

GRACE M. POWELL, Executrix of the Estate of  
O. E. Powell, Deceased,

Appellant,

vs.

RALPH C. GRANQUIST, District Director of  
Internal Revenue,

Appellee.

---

Transcript of Record

---

Appeal from the United States District Court for the  
District of Oregon



# INDEX

[Clerk's Note: When deemed likely to be of an important nature, errors or doubtful matters appearing in the original certified record are printed literally in italic; and, likewise, cancelled matter appearing in the original certified record is printed and cancelled herein accordingly. When possible, an omission from the text is indicated by printing in italic the two words between which the omission seems to occur.]

	PAGE
Answer .....	58
Attorneys, Names and Addresses of.....	1
Bond for Costs on Appeal.....	90
Certificate of Clerk.....	160
Complaint .....	3
Ex. A—Claim for Refund for Year End- ing December 31, 1937.....	28
B—Letter Dated October 7, 1954, Re 1937 .....	31
C—Claim for Refund for Year Ending December 31, 1938.....	32
D—Letter Dated October 7, 1954, Re 1938 .....	34
E—Claim for Refund for Year Ending December 31, 1939.....	35
F—Letter Dated October 7, 1954, Re 1939 .....	37
G—Claim for Refund for Year Ending December 31, 1940.....	38
H—Letter Dated October 7, 1954, Re 1940 .....	40

## Exhibits—(Continued):

I—Claim for Refund for Year Ending December 31, 1941.....	41
J—Letter Dated October 7, 1954, Re 1941 .....	43
K—Claim for Refund for Year Ending December 31, 1942.....	44
L—Letter Dated October 7, 1954, Re 1942 .....	46
M—Claim for Refund for Year Ending December 31, 1943.....	47
N—Letter Dated October 7, 1954, Re 1943 .....	50
O—Claim for Refund for Year Ending December 31, 1944.....	51
P—Letter Dated October 7, 1954, Re 1944 .....	53
Q—Claim for Refund for Year Ending December 31, 1945.....	54
R—Letter Dated October 7, 1954, Re 1945 .....	57
Findings of Fact and Conclusions of Law....	84
Judgment .....	89
Notice of Appeal.....	90
Opinion .....	77
Pretrial Order .....	67

INDEX	PAGE
Statement of Points on Appeal.....	162
Transcript of Proceedings.....	92
Witnesses:	
Armstrong, Carl P.	
—direct .....	96
—cross .....	102
—redirect .....	105
—recross .....	106
Forsberg, Daniel S.	
—direct .....	113
—cross .....	121
—redirect .....	126
—recross .....	128
Maier, Edward A.	
—direct .....	129
—cross .....	133
Milkes, Bernard	
—direct .....	147
—cross .....	153
—redirect .....	156
Parsons, Harold	
—direct .....	107
—cross .....	110
—redirect .....	112

## Witnesses—(Continued) :

Powell, Lee G.

—direct .....137, 157

—cross ..... 144

—redirect ..... 145

—direct ..... 94

Tucker, Cecil







## NAMES AND ADDRESSES OF ATTORNEYS

ARTHUR D. JONES,  
HUMPHRIES AND JONES,  
Yeon Building,  
Portland, Oregon;

FREDERICK A. JAHNKE,  
710 Cascade Building,  
Portland, Oregon,  
For Appellant.

CHARLES K. RICE,  
Asst. U. S. Attorney General;

LEE O. JACKSON,  
Attorney,  
Department of Justice,  
Washington 25, D. C.

C. E. LUCKEY,  
United States Attorney, and

EDWARD J. GEORGEFF,  
Assistant United States Attorney,  
United States Courthouse,  
Portland, Oregon,  
For Appellee.



In the District Court of the United States  
for the District of Oregon

Civil No. 7837

GRACE M. POWELL, Executrix of the Estate of  
O. E. POWELL, Deceased,

Plaintiff,

vs.

RALPH C. GRANQUIST, District Director of  
Internal Revenue,

Defendant.

### COMPLAINT

Comes Now the Plaintiff and for her first cause of action against the Defendant, complains and alleges as follows:

#### I.

That this is a Civil action and arises under the laws of the United States of America providing for Internal Revenue, and jurisdiction rests upon Title 28, United States Code, Sec. 1340.

#### II.

That O. E. Powell was, until his death on or about July 16, 1954, and at all times mentioned herein, a citizen and resident of Multnomah County, State of Oregon, and the United States.

#### III.

That the Plaintiff is the duly appointed and qualified Executrix of the estate of O. E. Powell, deceased, and was so appointed by the Circuit Court

of the County of Multnomah, State of Oregon, Probate Department, on or about September 21, 1954.

#### IV.

That the Defendant is the duly appointed and qualified District Director of Internal Revenue and was so appointed on or about October 31, 1952.

#### V.

That on or about September 25, 1950, the Commissioner of Internal Revenue mailed to the taxpayer, O. E. Powell, a letter asserting a deficiency in income taxes and penalties for the taxable year ended December 31, 1937, in the following amounts: Deficiency, \$100.99; Section 293(b), Internal Revenue Code penalty, \$50.50; and Section 291(a), Internal Revenue Code, penalty in the amount of \$25.25.

#### VI.

That the Commissioner explained in the aforementioned letter that the aforementioned deficiency was due to fraud with intent to evade tax within the meaning of Section 293(b), Internal Revenue Code, and therefore imposed said penalty for the taxable year ended December 31, 1937.

#### VII.

That the Commissioner explained in the aforementioned letter that the taxpayer, O. E. Powell, had failed to file timely income tax returns and therefore imposed the penalties as provided in Sec-

tion 291(a), Internal Revenue Code, for the taxable year ended December 31, 1937.

### VIII.

That no part of the aforementioned deficiency for the taxable year ended December 31, 1937, was due to fraud with intent to evade the tax within the meaning of Section 293(b), Internal Revenue Code. (Section 6653(b), Internal Revenue Code of 1954.)

### IX.

That the taxpayer's, O. E. Powell, failure to file timely income tax returns for the taxable year ended December 31, 1937, was due to reasonable cause and not due to wilful neglect within the meaning of Section 291(a), Internal Revenue Code (Section 6651, Internal Revenue Code of 1954).

### X.

That thereafter the taxes and penalties mentioned above were wrongfully, erroneously and arbitrarily assessed and the penalties mentioned above were wrongfully, erroneously and arbitrarily collected by the Defendant during the month of April, 1954, for the taxable year ended December 31, 1937.

### XI.

That thereafter on or about July 13, 1954, the taxpayer, O. E. Powell, duly filed a claim for refund of said taxes for the taxable year ended December 31, 1937, and a copy of said claim is attached hereto, marked "Exhibit A," and by this reference is made a part hereof.

## XII.

That thereafter by registered mail the Defendant mailed to O. E. Powell a letter bearing the date of October 7, 1954, and mailed October 11, 1954, notifying O. E. Powell that his claim for refund had been rejected for the year 1937, and a copy of said letter is attached hereto, marked "Exhibit B," and by this reference is made a part hereof.

## XIII.

That there is now due and owing by the Defendant to the Plaintiff the sum of \$75.75 together with interest as provided by law and that the Defendant is wrongfully, erroneously and arbitrarily withholding said amounts as penalties, as aforementioned, for the taxable year ended December 31, 1937.

For a Second Cause of Action Against the Defendant, the Plaintiff Complains and Alleges as Follows:

## I.

Realleges Paragraphs I to IV, inclusive, of her first cause of action.

## II.

That on or about September 25, 1950, the Commissioner of Internal Revenue mailed to the taxpayer, O. E. Powell, a letter asserting a deficiency in income taxes and penalties for the taxable year ended December 31, 1938, in the following amounts: Deficiency, \$102.10; Section 293(b), Internal Revenue Code penalty, \$51.05; and Section 291(a), In-

ternal Revenue Code penalty in the amount of \$25.23.

### III.

That the Commissioner explained in the aforementioned letter that the aforementioned deficiency was due to fraud with intent to evade tax within the meaning of Section 293(b), Internal Revenue Code, and therefore imposed said penalty as therein provided for the taxable year ended December 31, 1938.

### IV.

That the Commissioner explained in the aforementioned letter that the taxpayer, O. E. Powell, had failed to file timely income tax returns and therefore imposed the penalties as provided in Section 291(a), Internal Revenue Code, for the taxable year ended December 31, 1938.

### V.

That no part of the aforementioned deficiency for the taxable year ended December 31, 1938, was due to fraud with intent to evade the tax within the meaning of Section 293(b), Internal Revenue Code. (Section 6653(b), Internal Revenue Code of 1954.)

### VI.

That the taxpayer's, O. E. Powell, failure to file timely income tax returns for the taxable year ended December 31, 1938, was due to reasonable cause and not due to wilful neglect within the meaning of Section 291(a), Internal Revenue Code. (Section 6651, Internal Revenue Code of 1954.)

## VII.

That thereafter the taxes and penalties mentioned above were wrongfully, erroneously and arbitrarily assessed and the penalties mentioned above were wrongfully, erroneously and arbitrarily collected by the Defendant during the month of April, 1954, for the taxable year ended December 31, 1938.

## VIII.

That thereafter on or about July 13, 1954, the taxpayer, O. E. Powell, duly filed a claim for refund of said taxes for the taxable year ended December 31, 1938, and a copy of said claim is attached hereto, marked "Exhibit C," and by this reference is made a part hereof.

## IX.

That thereafter by registered mail the Defendant mailed to O. E. Powell a letter bearing the date of October 7, 1954, and mailed October 11, 1954, notifying O. E. Powell that his claim for refund had been rejected for the year 1938, and a copy of said letter is attached hereto, marked "Exhibit D," and by this reference is made a part hereof.

## X.

That there is now due and owing by the Defendant to the Plaintiff the sum of \$76.28 together with interest as provided by law and that the Defendant is wrongfully, erroneously and arbitrarily withholding said amounts as penalties, as aforementioned, for the taxable year ended December 31, 1938.



For a Third Cause of Action Against the Defendant, the Plaintiff Complains and Alleges as Follows:

I.

Realleges Paragraphs I to IV, inclusive, of her first cause of action.

II.

That on or about September 25, 1950, the Commissioner of Internal Revenue mailed to the taxpayer, O. E. Powell, a letter asserting a deficiency in income taxes and penalties for the taxable year ended December 31, 1939, in the following amounts: Deficiency, \$76.82; Section 293(b), Internal Revenue Code penalty, \$38.41; and Section 291(a), Internal Revenue Code, penalty in the amount of \$19.21.

III.

That the Commissioner explained in the aforementioned letter that the aforementioned deficiency was due to fraud with intent to evade tax within the meaning of Section 293(b), Internal Revenue Code, and therefore imposed said penalty as therein provided for the taxable year ended December 31, 1939.

IV.

That the Commissioner explained in the aforementioned letter that the taxpayer, O. E. Powell, had failed to file timely income tax returns and therefore imposed the penalties as provided in Section 291(a), Internal Revenue Code, for the taxable year ended December 31, 1939.

## V.

That no part of the aforementioned deficiency for the taxable year ended December 31, 1939, was due to fraud with intent to evade the tax within the meaning of Section 293(b), Internal Revenue Code. (Section 6653(b), Internal Revenue Code of 1954.)

## VI.

That the taxpayer's, O. E. Powell, failure to file timely income tax returns for the taxable year ended December 31, 1939, was due to reasonable cause and not due to wilful neglect within the meaning of Section 291(a), Internal Revenue Code. (Section 6651, Internal Revenue Code of 1954.)

## VII.

That thereafter the taxes and penalties mentioned above were wrongfully, erroneously and arbitrarily assessed and the penalties mentioned above were wrongfully, erroneously and arbitrarily collected by the Defendant during the month of April, 1954, for the taxable year ended December 31, 1939.

## VIII.

That thereafter on or about July 13, 1954, the taxpayer, O. E. Powell, duly filed a claim for refund of said taxes for the taxable year ended December 31, 1939, and a copy of said claim is attached hereto, marked "Exhibit E," and by this reference is made a part hereof.

## IX.

That thereafter by registered mail the Defendant mailed to O. E. Powell a letter bearing the date

of October 7, 1954, and mailed October 11, 1954, notifying O. E. Powell that his claim for refund had been rejected for the year 1939, and a copy of said letter is attached hereto, marked "Exhibit F," and by this reference is made a part hereof.

### X.

That there is now due and owing by the Defendant to the Plaintiff the sum of \$57.62, together with interest as provided by law and that the Defendant is wrongfully, erroneously and arbitrarily withholding said amounts as penalties, as aforementioned, for the taxable year ended December 31, 1939.

For a Fourth Cause of Action Against the Defendant, the Plaintiff Complains and Alleges as Follows:

#### I.

Realleges Paragraphs I to IV, inclusive, of her first cause of action.

#### II.

That on or about September 25, 1950, the Commissioner of Internal Revenue mailed to the taxpayer, O. E. Powell, a letter asserting a deficiency in income taxes and penalties for the taxable year ended December 31, 1940, in the following amounts: Deficiency, \$590.16; Section 293(b), Internal Revenue Code penalty, \$295.08; and Section 291(a), Internal Revenue Code penalty in the amount of \$147.54.

## III.

That the Commissioner explained in the aforementioned letter that the aforementioned deficiency was due to fraud with intent to evade tax within the meaning of Section 293(b), Internal Revenue Code, and therefore imposed said penalty as therein provided for the taxable year ended December 31, 1940.

## IV.

That the Commissioner explained in the aforementioned letter that the taxpayer, O. E. Powell, had failed to file timely income tax returns and therefore imposed the penalties as provided in Section 291(a), Internal Revenue Code, for the taxable year ended December 31, 1940.

## V.

That no part of the aforementioned deficiency for the taxable year ended December 31, 1940, was due to fraud with intent to evade the tax within the meaning of Section 293(b), Internal Revenue Code. (Section 6653(b), Internal Revenue Code of 1954.)

## VI.

That the taxpayer's, O. E. Powell, failure to file timely income tax returns for the taxable year ended December 31, 1940, was due to reasonable cause and not due to wilful neglect within the meaning of Section 291(a), Internal Revenue Code. (Section 6651, Internal Revenue Code of 1954.)

## VII.

That thereafter the taxes and penalties mentioned above were wrongfully, erroneously and arbitrarily

assessed and the penalties mentioned above were wrongfully, erroneously and arbitrarily collected by the Defendant during the month of April, 1954, for the taxable year ended December 31, 1940.

### VIII.

That thereafter on or about July 13, 1954, the taxpayer, O. E. Powell, duly filed a claim for refund of said taxes for the taxable year ended December 31, 1940, and a copy of said claim is attached hereto, marked "Exhibit G," and by this reference is made a part hereof.

### IX.

That thereafter by registered mail the Defendant mailed to O. E. Powell a letter bearing the date of October 7, 1954, and mailed October 11, 1954, notifying O. E. Powell that his claim for refund had been rejected for the year 1940, and a copy of said letter is attached hereto, marked "Exhibit H," and by this reference is made a part hereof.

### X.

That there is now due and owing by the Defendant to the Plaintiff the sum of \$442.62, together with interest as provided by law and that the Defendant is wrongfully, erroneously and arbitrarily withholding said amounts as penalties, as aforementioned, for the taxable year ended December 31, 1940.

For a Fifth Cause of Action Against the Defendant, the Plaintiff Complains and Alleges as Follows:

I.

Realleges Paragraphs I to IV, inclusive, for her first cause of action.

II.

That on or about September 25, 1950, the Commissioner of Internal Revenue mailed to the taxpayer, O. E. Powell, a letter asserting a deficiency in income taxes and penalties for the taxable year ended December 31, 1941, in the following amounts: Deficiency, \$1,027.81; Section 293(b), Internal Revenue Code penalty, \$513.91; and Section 291(a), Internal Revenue Code penalty in the amount of \$256.95.

III.

That the Commissioner explained in the aforementioned letter that the aforementioned deficiency was due to fraud with intent to evade tax within the meaning of Section 293(b), Internal Revenue Code, and therefore imposed said penalty as therein provided for the taxable year ended December 31, 1941.

IV.

That the Commissioner explained in the aforementioned letter that the taxpayer, O. E. Powell, had failed to file timely income tax returns and therefore imposed the penalties as provided in Section 291(a), Internal Revenue Code, for the taxable year ended December 31, 1941.

## V.

That no part of the aforementioned deficiency for the taxable year ended December 31, 1941, was due to fraud with intent to evade the tax within the meaning of Section 293(b), Internal Revenue Code. (Section 6653(b), Internal Revenue Code of 1954.)

## VI.

That the taxpayer's, O. E. Powell, failure to file timely income tax returns for the taxable year ended December 31, 1941, was due to reasonable cause and not due to wilful neglect within the meaning of Section 291(a), Internal Revenue Code. (Section 6651, Internal Revenue Code of 1954.)

## VII.

That thereafter the taxes and penalties mentioned above were wrongfully, erroneously and arbitrarily assessed and the penalties mentioned above were wrongfully, erroneously and arbitrarily collected by the Defendant during the month of April, 1954, for the taxable year ended December 31, 1941.

## VIII.

That thereafter on or about July 13, 1954, the taxpayer, O. E. Powell, duly filed a claim for refund of said taxes for the taxable year ended December 31, 1941, and a copy of said claim is attached hereto, marked "Exhibit I," and by this reference is made a part hereof.

## IX.

That thereafter by registered mail the Defendant mailed to O. E. Powell a letter bearing the date of

October 7, 1954, and mailed October 11, 1954, notifying O. E. Powell that his claim for refund had been rejected for the year 1941, a copy of said letter being attached hereto, marked "Exhibit J," and by this reference is made a part hereof.

### X.

That there is now due and owing by the Defendant to the Plaintiff the sum of \$770.86 together with interest as provided by law and that the Defendant is wrongfully, erroneously and arbitrarily withholding said amounts as penalties, as aforementioned, for the taxable year ended December 31, 1941.

For a Sixth Cause of Action Against the Defendant, the Plaintiff Complains and Alleges as Follows:

#### I.

Realleges Paragraphs I to IV, inclusive, of her first cause of action.

#### II.

That on or about September 25, 1950, the Commissioner of Internal Revenue mailed to the taxpayer, O. E. Powell, a letter asserting a deficiency in income taxes and penalties for the taxable year ended December 31, 1942, in the following amounts: Deficiency, \$3,853.66; Section 293(b), Internal Revenue Code penalty, \$1,926.83; and Section 291(a), Internal Revenue Code penalty in the amount of \$963.42.



## III.

That the Commissioner explained in the aforementioned letter that the aforementioned deficiency was due to fraud with intent to evade tax within the meaning of Section 293(b), Internal Revenue Code, and therefore imposed said penalty as therein provided for the taxable year ended December 31, 1942.

## IV.

That the Commissioner explained in the aforementioned letter that the taxpayer, O. E. Powell, had failed to file timely income tax returns and therefore imposed the penalties as provided in Section 291(a), Internal Revenue Code, for the taxable year ended December 31, 1942.

## V.

That no part of the aforementioned deficiency for the taxable year ended December 31, 1942, was due to fraud with intent to evade the tax within the meaning of Section 293(b), Internal Revenue Code. (Section 6653(b), Internal Revenue Code of 1954.)

## VI.

That the taxpayer's, O. E. Powell, failure to file timely income tax returns for the taxable year ended December 31, 1942, was due to reasonable cause and not due to wilful neglect within the meaning of Section 291 (a), Internal Revenue Code. (Section 6651, Internal Revenue Code of 1954.)

## VII.

That thereafter the taxes and penalties mentioned above were wrongfully, erroneously and arbitrarily assessed and the penalties mentioned above were wrongfully, erroneously and arbitrarily collected by the Defendant during the month of April, 1954, for the taxable year ended December 31, 1942.

## VIII.

That thereafter on or about July 13, 1954, the taxpayer, O. E. Powell, duly filed a claim for refund of said taxes for the taxable year ended December 31, 1942, and a copy of said claim is attached hereto, marked "Exhibit K," and by this reference is made a part hereof.

## IX.

That thereafter by registered mail the Defendant mailed to O. E. Powell a letter bearing the date of October 7, 1954, and mailed October 11, 1954, notifying O. E. Powell that his claim for refund had been rejected for the year 1942, and a copy of said letter is attached hereto, marked "Exhibit L," and by this reference is made a part hereof.

## X.

That there is now due and owing by the Defendant to the Plaintiff the sum of \$2,890.25 together with interest as provided by law and that the Defendant is wrongfully, erroneously and arbitrarily withholding said amounts as penalties, as aforementioned, for the taxable year ended December 31, 1942.

For a Seventh Cause of Action Against the Defendant, the Plaintiff Complains and Alleges as Follows:

I.

Realleges Paragraphs I to IV, inclusive, of her first cause of action.

II.

That on or about September 25, 1950, the Commissioner of Internal Revenue mailed to the taxpayer, O. E. Powell, a letter asserting a deficiency in income taxes and penalties for the taxable year ended December 31, 1943, in the following amounts: Deficiency, \$2,520.25; Section 293 (b), Internal Revenue Code penalty, \$1,260.13; Section 291 (a), Internal Revenue Code penalty in the amount of \$630.06; and Section 294 (d) (1) (A) and (B), Internal Revenue Code penalty in the amount of \$403.25.

III.

That the Commissioner explained in the aforementioned letter that the aforementioned deficiency was due to fraud with intent to evade tax within the meaning of Section 293 (b), Internal Revenue Code, and therefore imposed said penalty as therein provided for the taxable year ended December 31, 1943.

IV.

That the Commissioner explained in the aforementioned letter that the taxpayer, O. E. Powell, had failed to file timely income tax returns and therefore imposed the penalties as provided in Sec-

tion 291(a), Internal Revenue Code, for the taxable year ended December 31, 1943.

#### V.

That the Commissioner explained that the taxpayer, O. E. Powell, had failed to file a declaration of estimated tax and had failed to pay installments of estimated tax declared for such years and therefore asserted the penalties as provided for by Sections 294 (d) (1) (A) and (B), Internal Revenue Code, for the taxable year ended December 31, 1943.

#### VI.

That no part of the aforementioned deficiency for the taxable year ended December 31, 1943, was due to fraud with intent to evade the tax within the meaning of Section 293 (b), Internal Revenue Code. (Section 6653 (b), Internal Revenue Code of 1954.)

#### VII.

That the taxpayer's, O. E. Powell, failure to file timely income tax returns for the taxable year ended December 31, 1943, was due to reasonable cause and not due to wilful neglect within the meaning of Section 291 (a), Internal Revenue Code (Section 6651, Internal Revenue Code of 1954.)

#### VIII.

That the taxpayer's, O. E. Powell, failure to file a declaration of estimated tax and pay installments thereon was due to reasonable cause and not to wilful neglect within the meaning of Sections 294 (d) (1) (A) and (B), Internal Revenue Code, and that

the latter penalty does not in any event apply for the taxable year ended December 31, 1943.

## IX.

That thereafter the taxes and penalties mentioned above were wrongfully, erroneously and arbitrarily assessed and the penalties mentioned above were wrongfully, erroneously and arbitrarily collected by the Defendant during the month of April, 1954, for the taxable year ended December 31, 1943.

## X.

That thereafter on or about July 13, 1954, the taxpayer, O. E. Powell, duly filed a claim for refund of said taxes for the taxable year ended December 31, 1943, and a copy of said claim is attached hereto, marked "Exhibit M," and by this reference is made a part hereof.

## XI.

That thereafter by registered mail the Defendant mailed to O. E. Powell a letter bearing the date of October 7, 1954, and mailed October 11, 1954, notifying O. E. Powell that his claim for refund had been rejected for the year 1943, and a copy of said letter is attached hereto, marked "Exhibit N," and by this reference is made a part hereof.

## XII.

That there is now due and owing by the Defendant to the Plaintiff the sum of \$2,293.44 together with interest as provided by law and that the Defendant is wrongfully, erroneously and arbitrarily withholding said amounts as penalties, as afore-

mentioned for the taxable year ended December 31, 1943.

For an Eighth Cause of Action Against the Defendant, the Plaintiff Complains and Alleges as Follows:

I.

Realleges Paragraphs I to IV, inclusive, of her first cause of action.

II.

That on or about September 25, 1950, the Commissioner of Internal Revenue mailed to the taxpayer, O. E. Powell, a letter asserting a deficiency in income taxes and penalties for the taxable year ended December 31, 1944, in the following amounts: Deficiency, \$11,426.55; Section 293 (b), Internal Revenue Code penalty, \$5,713.28; Section 291 (a), Internal Revenue Code penalty in the amount of \$2,856.64; and Section 294 (d) (1) (A) and (B), Internal Revenue Code, penalty in the amount of \$1,828.25.

III.

That the Commissioner explained in the aforementioned letter that the aforementioned deficiency was due to fraud with intent to evade tax within the meaning of Section 293 (b), Internal Revenue Code, and therefore imposed said penalty as therein provided for the taxable year ended December 31, 1944.

IV.

That the Commissioner explained in the aforementioned letter that the taxpayer, O. E. Powell,

had failed to file timely income tax returns and therefore imposed the penalties as provided in Section 291 (a), Internal Revenue Code, for the taxable year ended December 31, 1944.

#### V.

That the Commissioner explained that the taxpayer, O. E. Powell, had failed to file a declaration of estimated tax and had failed to pay installments of estimated tax declared for such years and therefore asserted the penalties as provided for by Sections 294 (d) (1) (A) and (B), Internal Revenue Code, for the taxable year ended December 31, 1944.

#### VI.

That no part of the aforementioned deficiency for the taxable year ended December 31, 1944, was due to fraud with intent to evade the tax within the meaning of Section 293 (b), Internal Revenue Code. (Section 6653 (b), Internal Revenue Code of 1954.)

#### VII.

That the taxpayer's, O. E. Powell, failure to file timely income tax returns for the taxable year ended December 31, 1944, was due to reasonable cause and not due to wilful neglect within the meaning of Section 291 (a), Internal Revenue Code. (Section 6651, Internal Revenue Code of 1954.)

#### VIII.

That the taxpayer's, O. E. Powell, failure to file a declaration of estimated tax and pay installments thereon was due to reasonable cause and not to

wilful neglect within the meaning of Sections 294 (d) (1) (A) and (B), Internal Revenue Code, and that the latter penalty does not in any event apply for the taxable year ended December 31, 1944.

### IX.

That thereafter the taxes and penalties mentioned above were wrongfully, erroneously and arbitrarily assessed and the penalties mentioned above were wrongfully, erroneously and arbitrarily collected by the Defendant during the month of April, 1954, for the taxable year ended December 31, 1944.

### X.

That thereafter on or about July 13, 1954, the taxpayer, O. E. Powell, duly filed a claim for refund of said taxes for the taxable year ended December 31, 1944, and a copy of said claim is attached hereto, marked "Exhibit O," and by this reference is made a part hereof.

### XI.

That thereafter by registered mail the Defendant mailed to O. E. Powell a letter bearing the date of October 7, 1954, and mailed October 11, 1954, notifying O. E. Powell that his claim for refund had been rejected for the year 1944, and a copy of said letter is attached hereto, marked "Exhibit P," and by this reference is made a part hereof.

### XII.

That there is now due and owing by the Defendant to the Plaintiff the sum of \$10,398.17 together with interest as provided by law and that the De-



defendant is wrongfully, erroneously and arbitrarily withholding said amounts as penalties as aforementioned for the taxable year ended December 31, 1944.

For a Ninth Cause of Action Against the Defendant, the Plaintiff Complains and Alleges as Follows:

I.

Realleges Paragraphs I to IV, inclusive, of her first cause of action.

II.

That on or about September 25, 1950, the Commissioner of Internal Revenue mailed to the taxpayer, O. E. Powell, a letter asserting a deficiency in income taxes and penalties for the taxable year ended December 31, 1945, in the following amounts: Deficiency, \$6,062.40; Section 293 (b), Internal Revenue Code penalty, \$3,031.20; Section 291 (a), Internal Revenue Code, penalty in the amount of \$1,515.60; and Section 294 (d) (1) (A) and (B), Internal Revenue Code penalty in the amount of \$969.98.

III.

That the Commissioner explained in the aforementioned letter that the aforementioned deficiency was due to fraud with intent to evade tax within the meaning of Section 293 (b), Internal Revenue Code, and therefore imposed said penalty as therein provided for the taxable year ended December 31, 1945.

## IV.

That the Commissioner explained in the aforementioned letter that the taxpayer, O. E. Powell, had failed to file timely income tax returns and therefore imposed the penalties as provided in Section 291 (a), Internal Revenue Code, for the taxable year ended December 31, 1945.

## V.

That the Commissioner explained that the taxpayer, O. E. Powell, had failed to file a declaration of estimated tax and had failed to pay installments of estimated tax declared for such years and therefore asserted the penalties as provided for by Sections 294 (d) (1) (A) and (B), Internal Revenue Code, for the taxable years ended December 31, 1945.

## VI.

That no part of the aforementioned deficiency for the taxable year ended December 31, 1945, was due to fraud with intent to evade the tax within the meaning of Section 293 (b), Internal Revenue Code. (Section 6653 (b), Internal Revenue Code of 1954.)

## VII.

That the taxpayer's, O. E. Powell, failure to file timely income tax returns for the taxable year ended December 31, 1945, was due to reasonable cause and not due to wilful neglect within the meaning of Section 291 (a), Internal Revenue Code. (Section 6651, Internal Revenue Code of 1954.)

## VIII.

That the taxpayer's, O. E. Powell, failure to file a declaration of estimated tax and pay installments thereon was due to reasonable cause and not to wilful neglect within the meaning of Sections 294 (d) (1) (A) and (B), Internal Revenue Code, and that the latter penalty does not in any event apply for the taxable year ended December 31, 1945.

## IX.

That thereafter the taxes and penalties mentioned above were wrongfully, erroneously and arbitrarily assessed and the penalties mentioned above were wrongfully, erroneously and arbitrarily collected by the Defendant during the month of April, 1954, for the taxable years ended December 31, 1945.

## X.

That thereafter on or about July 13, 1954, the taxpayer, O. E. Powell, duly filed a claim for refund of said taxes for the taxable year ended December 31, 1945, and a copy of said claim is attached hereto, marked "Exhibit Q," and by this reference is made a part hereof.

## XI.

That thereafter by registered mail the Defendant mailed to O. E. Powell a letter bearing the date of October 7, 1954, and mailed October 11, 1954, notifying O. E. Powell that his claim for refund had been rejected for the year 1945, and a copy of said letter is attached hereto, marked "Exhibit R," and by this reference is made a part hereof.

## XII.

That there is now due and owing by the Defendant to the Plaintiff the sum of \$5,516.78 together with interest as provided by law and that the Defendant is wrongfully, erroneously and arbitrarily withholding said amounts as penalties as aforementioned for the taxable year ended December 31, 1945.

Wherefore, the Plaintiff demands judgment against the Defendant for the sum of \$22,521.77 together with interest from the date of payment of said sum, and costs.

/s/ ARTHUR D. JONES,  
HUMPHREYS & JONES,  
Attorneys for Plaintiff.

Duly verified.

## “EXHIBIT A”

(Copy)

Form 843  
U. S. Treasury Department  
Internal Revenue Service

## Claim

To Be Filed With the District Director Where  
Assessment Was Made or Tax Paid

The District Director will indicate in the block below the kind of claim filed, and fill in, where required, the certificate on the back of this form.

- Refund of Taxes Illegally, Erroneously, or Excessively Collected.
- Refund of Amount Paid for Stamps Unused, or Used in Error or Excess.
- Abatement of Tax Assessed (not applicable to estate, gift, or income taxes).

District Director's Stamp (Date received): [Blank]

Name of taxpayer or purchaser of stamps:

O. E. Powell.

Street address: 3603 N. E. Klickitat.

City, postal zone number, and State:

Portland, Oregon.

1. District in which return (if any) was filed: Oregon.
2. Period (if for tax reported on annual basis, prepare separate form for each taxable year) from Jan. 1, 1937, to Dec. 31, 1937.
3. Kind of tax: Income Tax.
4. Amount of assessment, \$176.74; dates of payment, various (penalties only).

\* \* \*

6. Amount to be refunded: \$75.75.\*

\* \* \*

The claimant believes that this claim should be allowed for the following reasons:

---

\*Together with interest from date of payment as provided by law.

The commissioner of Internal Revenue assessed a deficiency in income taxes for the calendar year ended December 31, 1937, in the amount of \$100.99 and determined penalties pursuant to Section 293 (b) L.R.C. in the amount of \$50.50 and penalties pursuant Section 291 (a) I.R.C. in the amount of \$25.25.

That no part of said deficiency was due to fraud with intent to evade the tax within the meaning of Section 293 (b) I.R.C.

That the taxpayer's failure to file a timely return (Form 1040) was due to reasonable cause and not due to wilful neglect.

I declare under the penalties of perjury that this claim (including any accompanying schedules and statements) has been examined by me and to the best of my knowledge and belief is true and correct.

/s/ O. E. POWELL.

Dated May 27, 1954.

“EXHIBIT B”

(Copy)

U. S. Treasury Department  
Office of the Director of Internal Revenue  
830 N. E. Holladay  
Portland 14, Ore.

Oct. 7, 1954.

In replying refer to: C:A:CL

Mr. O. E. Powell,  
4805 S. W. Sunset Rd.,  
Portland, Ore.

Dear Mr. Powell:

In re: Claim for refund of Income Tax,  
\$75.75 for the period 1937.

In accordance with the provisions of section 3772 (a) (2) of the Internal Revenue Code, this notice of disallowance in full of your claim or claims is hereby given by registered mail.

By direction of the Commissioner.

Very truly yours,

/s/ R. C. GRANQUIST,  
District Director.

## "EXHIBIT C"

(Copy)

Form 843

U. S. Treasury Department

Internal Revenue Service

## Claim

To Be Filed With the District Director Where  
Assessment Was Made or Tax Paid

The District Director will indicate in the block below the kind of claim filed, and fill in, where required, the certificate on the back of this form.

- Refund of Taxes Illegally, Erroneously, or Excessively Collected.
- Refund of Amount Paid for Stamps Unused, or Used in Error or Excess.
- Abatement of Tax Assessed (not applicable to estate, gift, or income taxes).

District Director's Stamp (Date received): [Blank]

Name of taxpayer or purchaser of stamps:

O. E. Powell.

Street address: 3603 N. E. Klickitat.

City, postal zone number, and State:

Portland, Oregon.

1. District in which return (if any) was filed:  
Oregon.
2. Period (if for tax reported on annual basis, prepare separate form for each taxable year) from  
January 1, 1938, to Dec. 31, 1938.



3. Kind of tax: Income taxes and penalties.
4. Amount of assessment, \$178.38; dates of payment, various (penalties only).

\* \* \*

6. Amount to be refunded, \$76.28.\*

\* \* \*

The claimant believes that this claim should be allowed for the following reasons:

That the Commissioner of Internal Revenue assessed a deficiency in income taxes for the calendar year 1938 in the amount of \$102.10 and determined penalties pursuant to Section 293 (b) I.R.C. in the amount of \$51.05 and penalties pursuant to Section 291 (a) I.R.C. in the amount of \$25.23.

That no part of said deficiency was due to fraud with intent to evade the tax within the meaning of Section 293 (b) I.R.C.

That the taxpayer's failure to file a timely return (Form 1040) was due to reasonable cause and not due to wilful neglect.

I declare under the penalties of perjury that this claim (including any accompanying schedules and statements) has been examined by me and to the best of my knowledge and belief is true and correct.

/s/ O. E. POWELL.

Dated May 27, 1954.

---

\*Together with interest from date of payment as provided by law.

## "EXHIBIT D"

(Copy)

U. S. Treasury Department  
Office of the Director of Internal Revenue  
830 N. E. Holladay  
Portland 14, Ore.

Oct. 7, 1954.

In replying refer to: C:A:CL

Mr. O. E. Powell,  
4805 S. W. Sunset Rd.,  
Portland, Ore.

Dear Mr. Powell:

In re: Claim for refund of Income Tax,  
\$76.28 for the period year 1938.

In accordance with the provisions of section 3772 (a) (2) of the Internal Revenue Code, this notice of disallowance in full of your claim or claims is hereby given by registered mail.

By direction of the Commissioner.

Very truly yours,

/s/ R. C. GRANQUIST,  
District Director.

“EXHIBIT E”

(Copy)

Form 843

U. S. Treasury Department  
Internal Revenue Service

Claim

To Be Filed With the District Director Where  
Assessment Was Made or Tax Paid

The District Director will indicate in the block below the kind of claim filed, and fill in, where required, the certificate on the back of this form.

- Refund of Taxes Illegally, Erroneously, or Excessively Collected.
- Refund of Amount Paid for Stamps Unused, or Used in Error or Excess.
- Abatement of Tax Assessed (not applicable to estate, gift, or income taxes).

District Director's Stamp (Date received): [Blank]

Name of taxpayer or purchaser of stamps:  
O. E. Powell.

Street address: 3603 N. E. Klickitat.

City, postal zone number, and State:  
Portland, Oregon.

1. District in which return (if any) was filed:  
Oregon.

2. Period (if for tax reported on annual basis, prepare separate form for each taxable year) from Jan. 1, 1939, to Dec. 31, 1939.
3. Kind of tax: Income tax and penalties.
4. Amount of assessment, \$134.44; dates of payment, various (penalties only.)

\* \* \*

6. Amount to be refunded: \$57.62.\*

\* \* \*

The claimant believes that this claim should be allowed for the following reasons:

That the Commissioner of Internal Revenue assessed a deficiency in income taxes for the calendar year ended December 31, 1939, in the amount of \$76.82 and determined penalties pursuant to Section 293 (b) I.R.C. in the amount of \$38.41 and penalties pursuant to Section 291 (a) I.R.C. in the amount of \$19.21.

That no part of said deficiency was due to fraud with intent to evade the tax within the meaning of Section 293 (b) I.R.C.

That the taxpayer's failure to file a timely return (Form 1040) was due to reasonable cause and not due to wilful neglect.

I declare under the penalties of perjury that this claim (including any accompanying schedules and

---

\*Together with interest from date of payment as provided by law.

statements) has been examined by me and to the best of my knowledge and belief is true and correct.

/s/ O. E. POWELL.

Dated May 27, 1954.

“EXHIBIT F”

(Copy)

U. S. Treasury Department  
Office of the Director of Internal Revenue  
830 N. E. Holladay  
Portland 14, Ore.

Oct. 7, 1954.

In replying refer to: C:A:CL

Mr. O. E. Powell,  
4805 S. W. Sunset Rd.,  
Portland, Ore.

Dear Mr. Powell:

In re: Claim for refund of Income Tax,  
Amount \$57.62 for the period year  
1939.

In accordance with the provisions of section 3772 (a) (2) of the Internal Revenue Code, this notice of disallowance in full of your claim or claims is hereby given by registered mail.

By direction of the Commissioner.

Very truly yours,

/s/ R. C. GRANQUIST,  
District Director.

“EXHIBIT G”

(Copy)

Form 843

U. S. Treasury Department  
Internal Revenue Service

Claim

To Be Filed With the District Director Where  
Assessment Was Made or Tax Paid

The District Director will indicate in the block below the kind of claim filed, and fill in, where required, the certificate on the back of this form.

- Refund of Taxes Illegally, Erroneously, or Excessively Collected.
- Refund of Amount Paid for Stamps Unused, or Used in Error or Excess.
- Abatement of Tax Assessed (not applicable to estate, gift, or income taxes).

District Director's Stamp (Date received): [Blank]

Name of taxpayer or purchaser of stamps:

O. E. Powell.

Street address: 3603 N. E. Klickitat.

City, postal zone number, and State:

Portland, Oregon.

1. District in which return (if any) was filed:  
Oregon.
2. Period (if for tax reported on annual basis, prepare separate form for each taxable year) from Jan. 1, 1940, to Dec. 31, 1940.
3. Kind of tax: Income tax and penalties.
4. Amount of assessment, \$1,032.78; dates of payment, various (penalties only).

\* \* \*

6. Amount to be refunded: \$442.62.\*

\* \* \*

The claimant believes that this claim should be allowed for the following reasons:

That the Commissioner of Internal Revenue assessed a deficiency in income taxes for the calendar year ended December 31, 1940, in the amount of \$590.16 and determined penalties pursuant to 293 (b) I.R.C. in the amount of \$295.08 and penalties pursuant to Section 291 (a) I.R.C. in the amount of \$147.54.

That no part of said deficiency was due to fraud with intent to evade the tax within the meaning of Section 293 (b) I.R.C.

---

\*Together with interest from date of payment as provided by law.

That the taxpayer's failure to file a timely return (Form 1040) was due to reasonable cause and not due to wilful neglect.

I declare under the penalties of perjury that this claim (including any accompanying schedules and statements) has been examined by me and to the best of my knowledge and belief is true and correct.

/s/ O. E. POWELL.

Dated May 27, 1954.

“EXHIBIT H”

(Copy)

U. S. Treasury Department  
Office of the Director of Internal Revenue  
830 N. E. Holladay  
Portland 14, Ore.

Oct. 7, 1954.

In replying refer to: C:A:CL

Mr. O. E. Powell,  
4805 S. W. Sunset Rd.,  
Portland, Ore.

Dear Mr. Powell:

In re: Claim for refund of Income Tax,  
\$442.62 for the period year 1940.

In accordance with the provisions of section 3772 (a) (2) of the Internal Revenue Code, this



notice of disallowance in full of your claim or claims is hereby given by registered mail.

By direction of the Commissioner.

Very truly yours,

/s/ R. C. GRANQUIST,  
District Director.

“EXHIBIT I”

(Copy)

Form 843

U. S. Treasury Department  
Internal Revenue Service

Claim

To Be Filed With the District Director Where  
Assessment Was Made or Tax Paid

The District Director will indicate in the block below the kind of claim filed, and fill in, where required, the certificate on the back of this form.

- Refund of Taxes Illegally, Erroneously, or Excessively Collected.
- Refund of Amount Paid for Stamps Unused, or Used in Error or Excess.
- Abatement of Tax Assessed (not applicable to estate, gift, or income taxes).

District Director's Stamp (Date received): [Blank]

Name of Taxpayer or purchaser of stamps:  
O. E. Powell.

Street address: 3603 N. E. Klickitat.

City, postal zone number, and State:  
Portland, Oregon.

1. District in which return (if any) was filed:  
Oregon.
2. Period (if for tax reported on annual basis, prepare separate form for each taxable year) from Jan. 1, 1941, to Dec. 31, 1941.
3. Kind of tax: Income tax and penalties.
4. Amount of assessment, \$1,798.67; dates of payment, various (penalties only).

\* \* \*

6. Amount to be refunded: \$770.86.\*

\* \* \*

The claimant believes that this claim should be allowed for the following reasons:

That the Commissioner of Internal Revenue assessed a deficiency in income taxes for the calendar year ended December 31, 1941, in the amount of \$1,027.81 and determined penalties pursuant to section 293 (b) I.R.C. in the amount of \$513.91 and penalties pursuant to Section 291 (a) I.R.C. in the amount of \$256.95.

That no part of said deficiency was due to fraud with intent to evade the tax within the meaning of Section 293 (b) I.R.C.

---

\*Together with interest from date of payment as provided by law.

That the taxpayer's failure to file a timely return (Form 1040) was due to reasonable cause and not due to wilful neglect.

I declare under the penalties of perjury that this claim (including any accompanying schedules and statements) has been examined by me and to the best of my knowledge and belief is true and correct.

/s/ O. E. POWELL.

Dated May 27, 1954.

“EXHIBIT J”

(Copy)

U. S. Treasury Department  
Office of the Director of Internal Revenue  
830 N. E. Holladay  
Portland 14, Ore.

Oct. 7, 1954.

In replying refer to: C:A:CL

Mr. O. E. Powell,  
4805 S. W. Sunset Rd.,  
Portland, Ore.

Dear Mr. Powell:

In re: Claim for refund of Income Tax,  
\$770.86 for the period year 1941.

In accordance with the provisions of section 3772 (a) (2) of the Internal Revenue Code, this

notice of disallowance in full of your claim or claims is hereby given by registered mail.

By direction of the Commissioner.

Very truly yours,

/s/ R. C. GRANQUIST,  
District Director.

“EXHIBIT K”

(Copy)

Form 843

U. S. Treasury Department

Internal Revenue Service

Claim

To Be Filed With the District Director Where  
Assessment was made or Tax Paid

The District Director will indicate in the block below the kind of claim filed, and fill in, where required, the certificate on the back of this form.

- Refund of Taxes Illegally, Erroneously, or Excessively Collected.
- Refund of Amount Paid for Stamps Unused, or Used in Error or Excess.
- Abatement of Tax Assessed (not applicable to estate, gift, or income taxes).

District Director's Stamp (Date received): [Blank]

Name of taxpayer or purchaser of stamps:

O. E. Powell.

Street address: 3603 N. E. Klickitat.

City, postal zone number, and State:

Portland, Oregon.

1. District in which return (if any) was filed:  
Oregon.
2. Period (if for tax reported on annual basis, prepare separate form for each taxable year) from Jan. 1, 1942, to Dec. 31, 1942.
3. Kind of tax: Income tax and penalties.
4. Amount of assessment, \$6,743.91; dates of payment, various (penalties only).

\* \* \*

6. Amount to be refunded: \$2,890.25.\*

\* \* \*

The claimant believes that this claim should be allowed for the following reasons:

That the Commissioner of Internal Revenue assessed a deficiency in income taxes for the calendar year ended December 31, 1942, in the amount of \$3,853.66 and determined penalties pursuant to Section 293 (b), I.R.C., in the amount of \$1,926.83 and penalties pursuant to Section 291 (a), I.R.C., in the amount of \$963.42.

---

\*Together with interest from date of payment as provided by law.

That no part of said deficiency was due to fraud with intent to evade the tax within the meaning of Section 293 (b), I.R.C.

That the taxpayer's failure to file a timely return (Form 1040) was due to reasonable cause and not due to wilful neglect.

I declare under the penalties of perjury that this claim (including any accompanying schedules and statements) has been examined by me and to the best of my knowledge and belief is true and correct.

/s/ O. E. POWELL.

Dated May 27, 1954.

“EXHIBIT L”

(Copy)

U. S. Treasury Department  
Office of the Director of Internal Revenue  
830 N.E. Holladay  
Portland 14, Ore.

Oct. 7, 1954.

In Replying Refer to:

C:A:CL

Mr. O. E. Powell,  
4805 S.W. Sunset Rd.,  
Portland, Ore.

Dear Mr. Powell:

In re: Claim for refund of Income Tax,  
\$2,890.25 for the period year 1942.

In accordance with the provisions of Section 3772 (a)(2) of the Internal Revenue Code, this notice of disallowance in full of your claim or claims is hereby given by registered mail.

By direction of the Commissioner.

Very truly yours,

/s/ R. C. GRANQUIST,  
District Director.

“EXHIBIT M”

(Copy)

Form 843

U. S. Treasury Department  
Internal Revenue Service

Claim

To Be Filed With the District Director Where  
Assessment Was Made or Tax Paid

The District Director will indicate in the block below the kind of claim filed, and fill in, where required, the certificate on the back of this form.

- Refund of Taxes Illegally, Erroneously, or Excessively Collected.
- Refund of Amount Paid for Stamps Unused, or Used in Error or Excess.

- Abatement of Tax Assessed (not applicable to estate, gift, or income taxes).

District Director's Stamp (Date received): [Blank]

Name of taxpayer or purchaser of stamps: O. E. Powell.

Street address: 3603 N.E. Klickitat.

City, postal zone number, and States: Portland, Oregon.

1. District in which return (if any) was filed: Oregon.
2. Period (if for tax reported on annual basis, prepare separate form for each taxable year) from: Jan. 1, 1943, to Dec. 31, 1943.
3. Kind of tax: Income tax and penalties.
4. Amount of assessment, \$4,813.69; dates of payment, April, 1954 (penalties only).

\* \* \*

6. Amount to be refunded: \$2,293.44.\*

\* \* \*

The claimant believes that this claim should be allowed for the following reasons:

That the Commissioner of Internal Revenue assessed a deficiency in income taxes for the calendar

---

\*Together with interest from date of payment as provided by law.



year ended December 31, 1943, in the amount of \$2,520.25 and determined penalties pursuant to Section 293 (b), I.R.C., in the amount of \$1,260.13 and penalties pursuant to Section 291 (a), I.R.C., in the amount of \$630.06, and penalties pursuant to Section 294 (d)(1)(A) in the amount of \$252.03 and penalties pursuant to Section 294 (d)(1)(B) in the amount of \$151.22.

That no part of said deficiency was due to fraud with intent to evade the tax within the meaning of Section 293 (b), I.R.C.

That the taxpayer's failure to file a timely return (Form 1040) was due to reasonable cause and not due to wilful neglect.

That taxpayer's failure to file a timely declaration of estimated tax (Form 1040ES) and to make timely payments of the tax due thereon was due to reasonable cause and not due to wilful neglect.

I declare under the penalties of perjury that this claim (including any accompanying schedules and statements) has been examined by me and to the best of my knowledge and belief is true and correct.

/s/ O. E. POWELL.

Dated May 27, 1954.

## "EXHIBIT N"

(Copy)

U. S. Treasury Department  
Office of the Director of Internal Revenue  
830 N.E. Holladay  
Portland 14, Ore.

Oct. 7, 1954.

In Replying Refer to: C:A:CL

Mr. O. E. Powell,  
4805 S.W. Sunset Rd.,  
Portland, Ore.

Dear Mr. Powell:

In re: Claim for refund of Income tax,  
\$2,293.44 for the period year  
1943.

In accordance with the provisions of Section 3772  
(a)(2) of the Internal Revenue Code, this notice of  
disallowance in full of your claim or claims is  
hereby given by registered mail.

By direction of the Commissioner,

Very truly yours,

/s/ R. C. GRANQUIST,  
District Director.

“EXHIBIT O”

(Copy)

Form 843

U. S. Treasury Department  
Internal Revenue Service

Claim

To Be Filed With the District Director Where  
Assessment Was Made or Tax Paid

The District Director will indicate in the block below the kind of claim filed, and fill in, where required, the certificate on the back of this form.

- Refund of Taxes Illegally, Erroneously, or Excessively Collected.
- Refund of Amount Paid for Stamps Unused, or Used in Error or Excess.
- Abatement of Tax Assessed (not applicable to estate, gift, or income taxes).

District Director's Stamp (Date received): [Blank]

Name of taxpayer or purchaser of stamps: O. E. Powell.

Street address: 3603 N.E. Klickitat.

City, postal zone number, and State: Portland, Oregon.

1. District in which return (if any) was filed: Oregon.

2. Period (if for tax reported on annual basis, prepare separate form for each taxable year) from Jan. 1, 1944, to Dec. 31, 1944.
3. Kind of tax: Income tax and penalties.
4. Amount of assessment, \$21,824.72; dates of payment, April, 1954 (penalties only).

\* \* \*

6. Amount to be refunded: \$10,398.17.\*

\* \* \*

The claimant believes that this claim should be allowed for the following reasons:

That the Commissioner of Internal Revenue assessed a deficiency in income taxes for the calendar year ended December 31, 1944, in the amount of \$11,426.55 and determined penalties pursuant to Section 293 (b), I.R.C., in the amount of \$5,713.28 and penalties pursuant to Section 291 (a), I.R.C., in the amount of \$2,856.64, and penalties pursuant to Section 294 (d)(1)(A) in the amount of \$1,142.66 and penalties pursuant to Section 294 (d)(1)(B) in the amount of \$685.59.

That no part of said deficiency was due to fraud with intent to evade the tax within the meaning of Section 293 (b), I.R.C.

---

\*Together with interest from date of payment as provided by law.

That the taxpayer's failure to file a timely return (Form 1040) was due to reasonable cause and not due to wilful neglect.

That taxpayer's failure to file a timely declaration of estimated tax (Form 1040ES) and to make timely payments of the tax due thereon was due to reasonable cause and not due to wilful neglect.

I declare under the penalties of perjury that this claim (including any accompanying schedules and statements) has been examined by me and to the best of my knowledge and belief is true and correct.

/s/ O. E. POWELL.

Dated May 27, 1954.

“EXHIBIT P”

(Copy)

U. S. Treasury Department  
Office of the Director of Internal Revenue  
830 N.E. Holladay  
Portland 14, Ore.

Oct. 7, 1954.

In Replying Refer to: C:A:CL

Mr. O. E. Powell,  
4805 S.W. Sunset Rd.,  
Portland, Ore.

Dear Mr. Powell:

In re: Claim for refund of Income Tax,  
\$10,398.17 for the period year  
1944.

In accordance with the provisions of Section 3772 (a)(2) of the Internal Revenue Code, this notice of disallowance in full of your claim or claims is hereby given by registered mail.

By direction of the Commissioner.

Very truly yours,

/s/ R. C. GRANQUIST,  
District Director.

“EXHIBIT Q”

(Copy)

Form 843

U. S. Treasury Department  
Internal Revenue Service

Claim

To Be Filed With the District Director Where  
Assessment Was Made or Tax Paid

The District Director will indicate in the block below the kind of claim filed, and fill in, where required, the certificate on the back of this form.

- Refund of Taxes Illegally, Erroneously, or Excessively Collected.
- Refund of Amount Paid for Stamps Unused, or Used in Error or Excess.

Abatement of Tax Assessed (not applicable to estate, gift, or income taxes).

District Director's Stamp (Date received): [Blank]

Name of taxpayer or purchaser of stamps: O. E. Powell.

Street address: 3603 N.E. Klickitat.

City, postal zone number, and State: Portland, Oregon.

1. District in which return (if any) was filed: Oregon.
2. Period (if for tax reported on annual basis, prepare separate form for each taxable year) from Jan. 1, 1945, to Dec. 31, 1945.
3. Kind of tax: Income tax and penalties.
4. Amount of assessment, \$11,579.18; dates of payment, April, 1954 (penalties only).

\* \* \*

6. Amount to be refunded: \$5,516.78.\*

\* \* \*

The claimant believes that this claim should be allowed for the following reasons:

That the Commissioner of Internal Revenue assessed a deficiency in income taxes for the calendar

---

\*Together with interest from date of payment as provided by law.

year ended December 31, 1945, in the amount of \$6,062.40 and determined penalties pursuant to Section 293 (b), I.R.C., in the amount of \$3,031.20 and penalties pursuant to Section 291 (a), I.R.C., in the amount of \$1,515.60 and penalties pursuant to Section 294 (d)(1)(A) in the amount of \$606.24 and penalties pursuant to Section 294 (d)(1)(B) in the amount of \$363.74.

That no part of said deficiency was due to fraud with intent to evade the tax within the meaning of Section 293 (b), I.R.C.

That the taxpayer's failure to file a timely return (Form 1040) was due to reasonable cause and not due to wilful neglect.

That taxpayer's failure to file a timely declaration of estimated tax (Form 1040ES) and to make timely payments of the tax due thereon was due to reasonable cause and not due to wilful neglect.

I declare under the penalties of perjury that this claim (including any accompanying schedules and statements) has been examined by me and to the best of my knowledge and belief is true and correct.

/s/ O. E. POWELL.

Dated May 27, 1954.



“EXHIBIT R”

(Copy)

U. S. Treasury Department  
Office of the Director of Internal Revenue  
830 N.E. Holladay  
Portland 14, Ore.

Oct. 7, 1954.

In Replying Refer to: C:A:CL

Mr. O. E. Powell,  
4805 S.W. Sunset Rd.,  
Portland, Ore.

Dear Mr. Powell:

In re: Claim for refund of Income Tax,  
\$5,516.78 for the period year 1945.

In accordance with the provisions of Section 3772  
(a)(2) of the Internal Revenue Code, this notice of  
disallowance in full of your claim or claims is  
hereby given by registered mail.

By direction of the Commissioner.

Very truly yours,

/s/ R. C. GRANQUIST,  
District Director.

[Endorsed]: Filed December 15, 1954.

[Title of District Court and Cause.]

## ANSWER

Comes now the defendant, Ralph C. Granquist, District Director of Internal Revenue, by his attorney, Clarence Edwin Luckey, United States Attorney for the District of Oregon, in answer to the plaintiff's complaint herein:

### I.

Denies the allegations contained in said complaint not admitted, qualified or specifically referred to below.

### II.

Further answering plaintiff's complaint:

#### First Cause of Action

1. Admits the allegations contained in paragraph I.

2. Alleges that he is without knowledge or information sufficient to form a belief as to the truth of the allegations contained in paragraph II.

3. Alleges that he is without knowledge or information sufficient to form a belief as to the truth of the allegations contained in paragraph III.

4. Admits the allegations contained in paragraph IV.

5. Denies the allegations contained in paragraphs V, VI and VII but admits that the Commissioner mailed a letter dated September 25, 1950, to

the taxpayer and refers to that letter for a full, complete and accurate statement of the terms thereof.

6. Denies the allegations contained in paragraph VIII.

7. Denies the allegations contained in paragraphs IX and X.

8. Denies the allegations contained in paragraph XI but admits that on July 13, 1954, the taxpayer filed a claim for refund for the year 1937 and that a copy of said claim is attached to the complaint and marked Exhibit A but all statements in the claim are denied which are not otherwise admitted in this answer.

9. Admits the allegations contained in paragraph XII.

10. Denies the allegations contained in paragraph XIII.

#### Second Cause of Action

11. Repeats the answers to paragraphs I to IV, inclusive, of the First Cause of Action with the same force as fully set forth here.

12. Denies the allegations contained in paragraphs II, III and IV but admits that the Commissioner mailed a letter dated September 25, 1950, to the taxpayer and refers to that letter for a full, complete and accurate statement of the terms thereof.

13. Denies the allegations contained in paragraphs V, VI and VII.

14. Denies the allegations contained in paragraph VIII but admits that on July 13, 1954, taxpayer filed a claim for refund for the year 1938 and that a copy of said claim is attached to the complaint and marked Exhibit C but denies all statements in the claim that are not otherwise admitted in this answer.

15. Admits the allegations contained in paragraph IX.

16. Denies the allegations contained in paragraph X.

#### Third Cause of Action

17. Repeats the answers to paragraphs I to IV, inclusive, of the First Cause of Action with the same force as fully set forth here.

18. Denies the allegations contained in paragraphs II, III and IV but admits that the Commissioner mailed a letter dated September 25, 1950, to the taxpayer and refers to that letter for a full, complete and accurate statement of the terms thereof.

19. Denies the allegations contained in paragraphs V, VI and VII.

20. Denies the allegations contained in paragraph VIII but admits that on July 13, 1954, the plaintiff filed a claim for refund for the year 1939 and that a copy of said claim is attached to the

complaint and marked Exhibit E but denies all statements in the claim that are not otherwise admitted in this answer.

21. Admits the allegations contained in paragraph IX.

22. Denies the allegations contained in paragraph X.

Fourth Cause of Action

23. Repeats the answers to paragraphs I to IV, inclusive, of the First Cause of Action with the same force as fully set forth here.

24. Denies the allegations contained in paragraphs II, III and IV but admits that the Commissioner mailed a letter dated September 25, 1950, to the taxpayer and refers to that letter for a full, complete and accurate statement of the terms thereof.

25. Denies the allegations contained in paragraphs V, VI and VII.

26. Denies the allegations contained in paragraph VIII but admits that on July 13, 1954, the plaintiff filed a claim for refund for the year 1940 and a copy of said claim is attached to the complaint and marked Exhibit G but denies all statements in the claim that are not otherwise admitted in this answer.

27. Admits the allegations contained in paragraph IX.

28. Denies the allegations contained in paragraph X.

#### Fifth Cause of Action

29. Repeats the answers to paragraphs I to IV, inclusive, of the First Cause of Action with the same force as fully set forth here.

30. Denies the allegations contained in paragraphs II, III and IV but admits that the Commissioner mailed a letter dated September 25, 1950, to the taxpayer and refers to that letter for a full, complete and accurate statement of the terms thereof.

31. Denies the allegations contained in paragraphs V, VI and VII.

32. Denies the allegations contained in paragraph VIII but admits that on July 13, 1954, the plaintiff filed a claim for refund for the year 1941 and that a copy of said claim is attached to the complaint and marked Exhibit I but denies all statements in the claim that are not otherwise admitted in this answer.

33. Admits the allegations contained in paragraph IX.

34. Denies the allegations contained in paragraph X.

#### Sixth Cause of Action

35. Repeats the answers to paragraphs I to IV, inclusive, of the First Cause of Action with the same force as fully set forth here.

36. Denies the allegations contained in paragraphs II, III and IV but admits that the Commissioner mailed a letter dated September 25, 1950, to the taxpayer and refers to that letter for a full, complete and accurate statement of the terms thereof.

37. Denies the allegations contained in paragraphs V, VI and VII.

38. Denies the allegations contained in paragraph VIII but admits that on July 13, 1954, the plaintiff filed a claim for refund for the year 1942 and that a copy of said claim is attached to the complaint and marked Exhibit K but denies all statements in the claim that are not otherwise admitted in this answer.

39. Admits the allegations contained in paragraph IX.

40. Denies the allegations contained in paragraph X.

#### Seventh Cause of Action

41. Repeats the answers to paragraphs I to IV, inclusive, of the First Cause of Action with the same force as fully set forth here.

42. Denies the allegations contained in paragraphs II, III, IV and V but admits that the Commissioner mailed a letter dated September 25, 1950, to the taxpayer and refers to that letter for a full, complete and accurate statement of the terms thereof.

43. Denies the allegations contained in paragraphs VI, VII, VIII and IX.

44. Denies the allegations contained in paragraph X but admits that on July 13, 1954, the plaintiff filed a claim for refund for the year 1943 and that a copy of said claim is attached to the complaint and marked Exhibit M but denies all statements in the claim that are not otherwise admitted in this answer.

45. Admits the allegations contained in paragraph XI.

46. Denies the allegations contained in paragraph XII.

#### Eighth Cause of Action

47. Repeats the answers to paragraphs I to IV, inclusive, of the First Cause of Action with the same force as fully set forth here.

48. Denies the allegations contained in paragraphs II, III, IV and V but admits that the Commissioner mailed a letter dated September 25, 1950, to the taxpayer and refers to that letter for a full, complete and accurate statement of the terms thereof.

49. Denies the allegations contained in paragraphs VI, VII and VIII.

50. Denies the allegations contained in paragraph IX.

51. Denies the allegations contained in paragraph X but admits that on July 13, 1954, plaintiff



filed a claim for refund for the year 1944 and that a copy of said claim is attached to the complaint and marked Exhibit O but denies all statements in the claim that are not otherwise admitted in this answer.

52. Admits the allegations contained in paragraph XI.

53. Denies the allegations contained in paragraph XII.

#### Ninth Cause of Action

54. Repeats the answers to paragraphs I to IV, inclusive, of the First Cause of Action with the same force as fully set forth here.

55. Denies the allegations contained in paragraphs II, III, IV and V but admits that the Commissioner mailed a letter dated September 25, 1950, to the taxpayer and refers to that letter for a full, complete and accurate statement of the terms thereof.

56. Denies the allegations contained in paragraphs VI, VII, VIII and IX.

57. Denies the allegations contained in paragraph X but admits that on July 13, 1954, plaintiff filed a claim for refund for the year 1945 and that a copy of said claim is attached to the complaint and marked Exhibit Q but denies all statements in the claim that are not otherwise admitted in this answer.

58. Admits the allegations contained in paragraph XI.

59. Denies the allegations contained in paragraph XII.

#### Affirmative Defense

With respect to Paragraph VIII of the first cause of action, Paragraphs V in the second, third, fourth, fifth and sixth causes of action, and Paragraphs VI in the seventh, eighth and ninth causes of action set forth in plaintiff's complaint, this action will be defended on the basis that the taxpayer was guilty of fraud, with intent to evade tax within the meaning of Section 293(b) of the Internal Revenue Code.

Wherefore, the defendant prays that the complaint be dismissed and that defendant be allowed his costs and disbursements.

/s/ C. E. LUCKEY,  
United States Attorney;

/s/ EDWARD J. GEORGEFF,  
Assistant United States  
Attorney.

Affidavit of Service by Mail attached.

[Endorsed]: Filed February 16, 1955.

[Title of District Court and Cause.]

## PRETRIAL ORDER

The above matter coming on regularly for pretrial conference before the undersigned Judge of the above-entitled Court on the . . . . day of June, 1955,

Plaintiff appeared by Arthur D. Jones of Attorneys for Plaintiff, and the defendant appeared by Richard Roberts of Attorneys for Defendant. The parties, with the approval of the Court, agreed upon the following:

### Statement of Agreed Facts

#### I.

This is a civil action and arises under the laws of the United States of America providing for Internal Revenue, and jurisdiction rests upon Title 28, United States Code, Section 1340.

#### II.

O. E. Powell was, until his death on or about July 16, 1954, and at all times mentioned herein, a citizen and resident of Multnomah County, State of Oregon, and the United States.

#### III.

The plaintiff herein is the duly-appointed and qualified executrix of the estate of O. E. Powell, deceased, and was so appointed by the Circuit Court of the County of Multnomah, State of Oregon, Probate Department, on or about September 21, 1954.

## IV.

The defendant is a duly-appointed and qualified District Director of Internal Revenue and was so appointed on or about October 31, 1951.

## V.

On or about September 25, 1950, the Commissioner of Internal Revenue, over the signature of Geo. J. Schoeneman, mailed to the taxpayer, O. E. Powell, a letter asserting a deficiency in income taxes and penalties for each of the taxable years following and in the following amounts:

Year	Deficiency In Income Tax	50% Penalty	Sec. 291(a) Penalty	Sec. 294(d) Penalty
1937.....	\$ 100.99	\$ 50.50	\$ 25.25	\$
1938.....	102.10	51.05	25.23	
1939.....	76.82	38.41	19.21	
1940.....	590.16	295.08	147.54	
1941.....	1,027.81	513.91	256.95	
1942.....	3,853.66	1,926.83	963.42	
1943.....	2,520.25	1,260.13	630.06	403.25
1944.....	11,426.55	5,713.28	2,856.64	1,828.25
1945.....	6,062.40	3,031.20	1,515.60	969.98
	<hr/>	<hr/>	<hr/>	<hr/>
	\$25,760.74	\$12,880.39	\$6,439.90	\$3,201.48

## VI.

On or about August 12, 1949, the Commissioner of Internal Revenue over the signature of L. E. Hallowell, Internal Revenue Agent, mailed to the taxpayer a letter asserting deficiencies for each of the years as set out in Paragraph V above; thereafter on July 20, 1950, the Commissioner of Internal Revenue, over the signature of L. E. Hallowell, Acting Internal Revenue Agent in Charge, mailed to

the taxpayer a letter dated July 20, 1950, informing the said taxpayer that pursuant to taxpayer's protest he had transferred the proposed assessment for each of the taxable years in question to the technical staff at Portland, Oregon. Thereafter, the Commissioner of Internal Revenue mailed his letter, mentioned in Paragraph V, to the taxpayer asserting the deficiencies in the amounts mentioned in said Paragraph V and for each of the said years mentioned therein and afforded the taxpayer the right to file a petition with the Tax Court of the United States. The said taxpayer failed to file a petition with the Tax Court and the Commissioner of Internal Revenue in due course, after the mailing of the aforementioned letter, assessed the tax in the amounts mentioned above.

## VII.

The amount of taxes assessed against the taxpayer for each of the taxable years mentioned in Paragraph V above and in the amounts mentioned in said paragraph, exclusive of all of the penalties mentioned in said paragraph, are admitted by the plaintiff and defendant herein to be the correct amount of tax.

## VIII.

On the 10th day of May, 1937, O. E. Powell filed with the Collector of Internal Revenue for the District of Oregon, delinquent income tax returns for the taxable years 1933 to 1936, inclusive.

## IX.

That on or about the 9th day of March, 1948, the United States filed an Information against the taxpayer pursuant to Section 145(a) Internal Revenue Code, 26USC, 145(a), asserting that for the calendar years 1944 and 1945 taxpayer wilfully, knowingly and unlawfully failed to make income tax returns for the taxable years 1944 and 1945, and on May 24, 1949, O. E. Powell pleaded guilty to the above Information in the above-entitled Court.

## X.

All of the amounts in dispute in this proceedings have been paid by the plaintiff herein and/or O. E. Powell, and were so paid prior to filing the claims for refund mentioned in Paragraph XI following.

## XI.

On or about July 13, 1954, O. E. Powell filed timely claims for refund for each of the taxable years in controversy in the amounts as set out in Paragraph V, exclusive of the amounts set out in the column designating deficiency.

## XII.

The District Director of Internal Revenue, defendant herein, mailed to the taxpayer on or about October 7, 1954, his Notice of Disallowance in Full of all of the above-mentioned claims for refund by registered mail, and thereafter this suit for the refund of said taxes was commenced.

## Contentions of the Parties

## Defendant's Contentions

1. The defendant herein contends that the 50% penalties, imposed pursuant to Section 293(b) of the Internal Revenue Code of 1939 for each of the taxable years 1937 through 1945, inclusive, and in the amounts as set forth in Paragraph V of the admitted facts set out above under the column marked "50% Penalty," were properly assessed by the Commissioner of Internal Revenue and collected by the defendant herein.

2. The defendant contends that the Commissioner of Internal Revenue correctly assessed and the defendant herein correctly collected from O. E. Powell and/or the plaintiff herein, penalties for failure to file income tax returns, pursuant to Section 291(a) Internal Revenue Code of 1939, for each of the taxable years 1937 through 1945, inclusive, and in the amounts as set forth in Paragraph V of the admitted facts set out above under the column marked "Sec. 291(a) Penalty," and that the failure of O. E. Powell to file income tax returns was not due to reasonable cause and due to wilful neglect and that said amounts are not now due and owing to the said plaintiff from the said defendant.

3. The defendant contends that the Commissioner of Internal Revenue correctly assessed and the defendant herein correctly collected from O. E. Powell and/or plaintiff herein, penalties for failure to file declarations of estimated tax, pur-

suant to Section 294(d) (1) (A), Internal Revenue Code of 1939, and to pay said tax, pursuant to Section 294(d)(1)(B), Internal Revenue Code of 1939, for each of the taxable years 1943 through 1945, inclusive, and in the amounts set forth in Paragraph V of the admitted facts set out above under the column marked "Sec. 294(d) Penalty" and that the failure of O. E. Powell to file said declarations and pay said taxes was not due to reasonable cause and was due to wilful neglect and that said amounts are not now due and owing to the said plaintiff from the said defendant.

### Plaintiff's Contentions

1. The plaintiff contends that the Commissioner of Internal Revenue erroneously, arbitrarily and wrongfully assessed and the defendant herein erroneously, arbitrarily and wrongfully collected from O. E. Powell and/or the plaintiff herein, 50% fraud penalties, pursuant to Section 293(b), Internal Revenue Code of 1939, for each of the taxable years 1937 through 1945, inclusive, and in the amounts as set forth in Paragraph V of the admitted facts set out above under the column marked "50% Penalty," and that said amounts are now due and owing to the said plaintiff from the said defendant and no portion of said amounts has been repaid to the said plaintiff and/or O. E. Powell.

2. The plaintiff contends that the Commissioner of Internal Revenue erroneously, arbitrarily and wrongfully assessed and the defendant herein erroneously, arbitrarily and wrongfully collected from O. E. Powell and/or the plaintiff herein, penalties



for failure to file income tax returns, pursuant to Section 291(a), Internal Revenue Code of 1939, for each of the taxable years 1937 through 1945, inclusive, and in the amounts as set forth in Paragraph V of the admitted facts set out above under the column marked "Sec. 291(a) Penalty," and that the failure of O. E. Powell to file income tax returns was due to reasonable cause and not due to wilful neglect and that said amounts are now due and owing to the said plaintiff from the said defendant and no portion of said amounts has been repaid to the said plaintiff and/or O. E. Powell.

3. The plaintiff contends that the Commissioner of Internal Revenue erroneously, arbitrarily and wrongfully assessed and the defendant herein erroneously, arbitrarily and wrongfully collected from O. E. Powell and/or the plaintiff herein, penalties for failure to file declarations of estimated tax, pursuant to Section 294 (d) (1) (A), Internal Revenue Code of 1939, and to pay said tax, pursuant to Section 294 (d) (1) (B), Internal Revenue Code of 1939, for each of the taxable years 1943 through 1945, inclusive, and in the amounts set forth in Paragraph V of the admitted facts set out above under the column marked "Sec. 294(d) Penalty," and that the failure of O. E. Powell to file said declarations and pay said taxes was due to reasonable cause and not due to wilful neglect and that said amounts are now due and owing to the said plaintiff from the said defendant and no portion of said amounts has been repaid to the said plaintiff and/or O. E. Powell.

## Exhibits

The following may be offered in evidence without further identification or authentication, but subject to any and all objections on other grounds.

1. Federal income tax returns, Form 1040, of O. E. Powell for each of the taxable years 1933 to 1936, inclusive.
2. Federal income tax returns Form 1040, of O. E. Powell for each of the taxable years 1937 to 1945, inclusive.
3. Claims for refund of Federal income taxes, Form 843, of O. E. Powell for each of the taxable years 1937 to 1945, inclusive.
4. Treasury Department letter disallowing claims for refund, dated October 7, 1954, over the signature of R. C. Granquist.
5. Letter informing O. E. Powell of a proposed **deficiency**, dated August 12, 1949, over the signature of L. E. Hallowell.
6. Treasury Department letter transferring the proposed deficiency to the technical staff of the Bureau of Internal Revenue, dated July 20, 1950.
7. Treasury Department letter of the determination of the tax deficiency and the opportunity of taxpayer to petition the Tax Court of the United States for a redetermination of the deficiency, dated September 25, 1950, over the signature of Geo. J. Schoeneman.

8. Information filed in the District Court of the United States charging O. E. Powell with the wilful failure to make tax returns for the taxable years 1944 and 1945.

9. O. E. Powell's plea entered to the Information mentioned in item 8 above.

10. Copy of Request for Transcript of Account or Certification, Form 899, showing the amounts and dates of payment of income taxes and penalties assessed against O. E. Powell for the taxable years 1933 through 1945, inclusive.

The following Exhibits are offered in evidence by the defendant and are not agreed to by the plaintiff on any grounds as to their authenticity, and plaintiff reserves the right to make objection to the introduction of said exhibits on any grounds whatsoever.

11. State of Oregon tax returns, Form 40, for the taxable years 1935 through 1939, inclusive.

12. State of Oregon tax returns, Form 40, for the taxable year 1948.

13. Copy of letter dated September 21, 1936, directed by the State of Oregon Tax Commission to O. E. Powell.

14. Copy of letter dated in 1941 directed by the State of Oregon Tax Commission to O. E. Powell.

15. Copy of letter dated February 6, 1941, directed by the State of Oregon Tax Commission to O. E. Powell.

16. Copy of letter dated February 1, 1945, directed by the State of Oregon Tax Commission to O. E. Powell.

17. Copy of letter dated September 24, 1948, directed by the state of Oregon Tax Commission to O. E. Powell.

### Conclusion

The foregoing Pretrial Order is the result of a conference between the attorneys for the parties hereto and the Court. It is definite and comprehensive and isolates all of the issues of fact and law now existing between plaintiff and defendant. This Pretrial Order shall govern the course of the trial and shall not be changed or amended unless by consent of the parties and the Court or modified at the trial by the Court to prevent manifest injustice.

Dated this 7th day of February, 1956.

/s/ CHASE A. CLARK,  
Judge.

Approved:

/s/ ARTHUR D. JONES,  
Of Attorneys for Plaintiff.

/s/ RICHARD ROBERTS,  
Of Attorneys for Defendant.

Lodged December 19, 1955.

[Endorsed]: Filed February 7, 1956.

[Title of District Court and Cause.]

### OPINION

Clark, District Judge.

This is a civil action to recover certain sums assessed as penalties for failure to file tax returns and declarations of estimated tax, and for underestimate of estimated tax. The taxpayer, O. E. Powell, died shortly after this suit was instituted and the executrix of the estate was substituted as party plaintiff.

The taxpayer received taxable income for the years 1937 through 1945, but filed no federal income tax returns for those years and also failed to file declarations of estimated tax for 1943 through 1945. The failure of the taxpayer to so file came to the attention of the Internal Revenue Service in January, 1946; whereupon an investigation was begun to determine Powell's taxable income for the years involved. During the years 1937 to 1945, taxpayer owned and operated a number of gasoline service stations, later leasing them to the two sons, Lee G. Powell and Vincent O. Powell, receiving from them rental incomes. Also, taxpayer had, at various times during that period, 19 different properties that he rented, and also during that time he made in excess of 30 real estate sales, farms and residences, and also he had interest income on contracts and commissions from realty sales. In order to determine taxpayer's income it was necessary that the Internal Revenue agents search public records in four counties, determine from the sons how much they leased

the stations for, and contact real estate dealers and other parties to the various transactions. This was necessary because the taxpayer had indicated that he kept no records.

Deficiencies in income tax were ultimately determined and assessed for 1937 through 1945, together with fraud and negligence penalties and penalties for failure to file declaration of estimated tax and for a substantial underestimate of tax. The amounts assessed as tax and as penalties are not in controversy here, but only the correctness of the assessment of penalties. At the time of trial, counsel for taxpayer conceded the 25% penalty for wilful failure to file and also conceded the 10% penalty for failure to file declaration of estimated tax, leaving for this court's determination the correctness of the assessments of the 50% fraud penalty and the 6% penalty for substantial understatement of estimated tax.

Admitting the deficiencies in income tax assessed were the correct amount of taxes, taxpayer made payment of taxes and penalties, and this is a suit for refund of those penalties.

This Court has jurisdiction of the parties and the subject matter.

Internal Revenue Code of 1939, provides:

“Section 293. Additions to the tax in case of deficiency. \* \* \* (b) Fraud. If any part of any deficiency is due to fraud with intent to evade tax, then 50 per centum of the total amount of

the deficiency (in addition to such deficiency) shall be so assessed, collected, and paid, in lieu of the 50 per centum addition to the tax provided in Section 3612(d) (2).

(26 U. S. C. 1952 ed., Section 293.)

Was the taxpayer's failure to file income tax returns and pay income taxes for the years 1937 through 1945, due to fraud with intent to evade tax within the meaning of the statute?

It is elementary that fraud is never presumed and must be established by competent evidence. Fraud must generally be determined from surrounding inferences and circumstances fairly deduced from the conduct of the parties. "Badges of Fraud" as they are referred to in cases of this type, may include, but are not limited to, gross understatement of income, failure to keep proper books and records, failure to co-operate with investigating agents, and the giving of evasive answers. *Koscove vs. Commissioner*, 225 Fed. 2d 85 @ 87, citing other cases.

From the evidence presented and the record herein it is the opinion of this Court that all of these factors are present in some degree in this case.

As has been pointed out, this case does not involve income tax returns fraudulently filed, but rather is concerned with a situation where there were no tax returns filed at all.

It is the plaintiff's contention that the evidence fails to establish wilful commission on the part of

O. E. Powell, but merely shows passive conduct, which passive conduct does not disclose the fraud with intent to evade tax necessary for the assessment of the fraud penalty. Plaintiff relies on a case decided by the 8th Circuit, *First Trust and Savings Bank vs. U. S.*, 206 Fed. 2d 97, as being in support of that position.

The case cited and the present case differ in that the taxpayer in the *First Trust and Savings Bank* case, Mr. Kraftmeyer, although he wilfully failed to make returns required, had never been informed that he was required to file a return, and apparently was under the impression that he had no taxable income, and did not know that he owed any tax. There is further evidence that he co-operated fully with the Internal Revenue Agents.

In the instant case the evidence discloses that Mr. Powell, during this period of his failure to file, made it known that he was not in sympathy with the administration and did not like the way the Government was run and did not believe in paying taxes. He had further indicated that he was thinking of getting his things gathered together and moving out of the country—going to South America where he wouldn't have to pay taxes.

Powell's son testified that he told his father he should be paying income tax, that it was the thing for him to do, and he, the father, said he knew it, but that he didn't pay because he didn't believe in the way the Government was wasting the money; he



said he believed in taxation but he didn't believe that the Government should waste the money. His failure to file returns was based primarily upon political convictions.

There is no evidence in the record of alteration or concealment of bank statements, cancelled checks or real estate contracts by the taxpayer. Mr. Powell said he did not have records, and there is no evidence of these having been destroyed or falsely made. However, there was no need for him to make false records or destroy records in contemplation of an investigation by the Internal Revenue Service, when at that time the taxpayer wasn't making or filing any income tax returns. The same thing is true of concealment of assets and the other "badges of fraud" to which reference has been made. The mere fact that these acts were not apparent at the time he was failing to make returns does not mean that they didn't exist.

The records which Powell kept were adequate for him to carry on his business profitably, yet Powell never volunteered any records, information or contracts. It was only as various transactions were discovered by the Internal Revenue Agents and specific requests made for all records and documents pertinent thereto, that they were made available by the taxpayer.

Fraud implies bad faith, intentional wrongdoing and sinister motive. It is never implied or presumed. It may comprise conduct, whether of omission or

commission, involving a breach of legal duty and resulting in damage to that one to whom the duty is owed.

Negligence, whether slight or great, is not equivalent to the fraud with intent to evade tax named in the statute. The fraud meant is actual, intentional wrongdoing, and the intent required is the specific purpose to evade a tax believed to be owing. Mere negligence does not establish either. *Griffiths vs. Comm.*, 50 Fed. 2d 782.

Here Mr. Powell's omission was not accidental. It was purposeful, wilful and deliberate omission to file and pay income taxes. Should this Court hold that there was no fraud with intent to evade taxes in this case, it would open the door to all who desire to evade taxes to escape the fraud penalty merely by wilfully and deliberately failing to file. It is the opinion of the Court that this plaintiff's action in so doing, coupled with his failure to keep records and his lack of co-operation in making full disclosure of all real estate transactions to the investigating agents, constitute fraud with intent to evade payment of tax, and the fraud penalty provided by Sec. 293 (b), Internal Revenue Code, was properly assessed.

The second question for this Court to determine is the correctness of the penalty assessed for substantial understatement of estimated tax or whether such a penalty is excluded by the penalty for failure to file any declaration of estimated tax whatsoever?

Sec. 294 (d) (1) (A), Internal Revenue Code, provides a 10% penalty for failure to file declaration of estimated tax and Sec. 294 (d) (2) provides for a 6% penalty for substantial underestimate of estimated tax. The Government has assessed both penalties against this taxpayer.

The Government relies on cases decided by the Tax Court to the effect that no declaration of estimated tax is in effect a zero declaration and therefore, in cases such as this, would be a substantial underestimate of estimated tax.

This Court is not inclined to that view, but agrees with the District Court of Georgia in the case of *United States vs. Ridley*, 120 F. Supp. 530, in which the Court said, at page 538,

“ \* \* \* However, the addition of 6% for substantial underestimate of estimated tax is improper for the very obvious reason that the tax was not underestimated, indeed, the taxpayer filed no declaration of estimated tax at all and suffers the greater sanction of 10% addition to the tax for the failure, and the failure to pay the tax.”

In the opinion of this court this is correct because everyone failing to file a declaration would be guilty of an underestimate, and thus the greater penalty applies to take care of both failures on the part of the taxpayer.

In accordance with this view also is *Owen v. United States*, 134 Fed. Supp. 31, decided by the District Court of Nebraska.

For these reasons the plaintiff is entitled to recover the amount assessed as 6% penalty under Sec. 294(d)(2).

Counsel for the defendant Government may prepare Findings of Fact, Conclusions of Law and Judgment in accordance with the views expressed herein, submitting the original to the Court and serving a copy on opposing counsel.

[Endorsed]: Filed November 13, 1956.

---

[Title of District Court and Cause.]

## FINDINGS OF FACT AND CONCLUSIONS OF LAW

### Findings of Fact

1. This is a civil action brought to recover a total of \$22,521.09 in penalties assessed by the Commissioner of Internal Revenue against Ora E. Powell, deceased, for the years 1937 through 1945 and collected by Ralph C. Granquist, District Director of Internal Revenue.

2. Plaintiff is the duly qualified and appointed executrix of the Estate of Ora E. Powell.

3. Plaintiff conceded at the trial that the 25% penalties for willful failure to file income tax returns under Section 291 of the Internal Revenue Code and the 10% penalties assessed for failure to

file declarations of estimated tax under Section 294 (d)(1)(A) of the Internal Revenue Code were properly assessed. Plaintiff did not concede, however, that the 50% penalties for fraud with intent to evade tax under Section 293(b) and the 6% penalties for substantial underestimate of estimated tax under Section 294(d)(2) of the Internal Revenue Code were properly assessed.

4. Ora E. Powell received taxable income in each year for the years 1937 through 1945. He did not file federal income tax returns for those years, however, nor did he file any declaration of estimated tax for the years 1943 through 1945. The deficiencies in income tax subsequently assessed against him by the Commissioner of Internal Revenue, which plaintiff admits to be correct, together with the Section 293(b) and Section 294(d) penalties assessed, are as follows:

Year	Deficiency In Income Tax	Sec. 293(b) Penalty	Sec. 294(d) Penalty
1937.....	\$ 100.99	\$ 50.50	\$
1938.....	102.10	51.05	
1939.....	76.82	38.41	
1940.....	590.16	295.08	
1941.....	1,027.81	513.91	
1942.....	3,853.66	1,926.83	
1943.....	2,520.25	1,260.13	430.25
1944.....	11,426.55	5,713.28	1,828.25
1945.....	6,062.40	3,031.20	969.98
	<hr/>	<hr/>	<hr/>
	\$25,760.74	\$12,880.39	\$3,201.48

5. The taxable income received by Ora E. Powell during the years 1937 through 1945 consisted of profits from the operation of gasoline filling sta-

tions, rental of gasoline filling stations and profits on the sale of real estate.

6. Ora E. Powell was aware of his obligation to file federal income tax returns, having filed such returns for years prior to 1937. He was advised by an employee of the Oregon State Tax Commission and by one of his sons to file federal income tax returns.

7. Ora E. Powell made statements to internal revenue agents in 1946 and 1947 to the effect that his failure to file income tax returns was based upon his disagreement with the way in which the country was being run and that he did not believe in paying taxes. Ora E. Powell made statements to one of his sons that the reason he did not pay taxes was that he believed the Government was wasting money.

8. Ora E. Powell did not keep books and records adequate to show his income during the years 1937 through 1945. The deficiency assessments made by the Commissioner of Internal Revenue were based, in part, upon information obtained from public records and the records of other persons, including the lessees of his gasoline filling stations, real estate dealers, and the company from which he purchased gasoline.

9. On May 24, 1949, Ora E. Powell entered a plea of guilty to the charge of willfully, knowingly and unlawfully failing to file federal income tax returns for the years 1944 and 1945 in violation of Section 145(a) of the Internal Revenue Code.

10. Ora E. Powell gave evasive answers to the internal revenue agents attempting to ascertain his taxable income for the years 1937 through 1945 and did not co-operate with the agents in their investigation.

11. The failure of Ora E. Powell to file any federal income tax returns for the years 1937 through 1947 was knowing, willful and intentional, and was due to fraud with intent to evade tax.

12. Ora E. Powell did not file any declaration of estimated tax for the years 1943 through 1945. His failure to file such declaration was not due to reasonable cause.

### Conclusions of Law

1. This Court has jurisdiction over the subject matter and the parties.

2. With respect to the 50% fraud penalties assessed by the Commissioner of Internal Revenue against Ora E. Powell for the years 1937 through 1945, defendant has the burden of proving fraud with intent to evade tax by clear and convincing evidence.

3. With respect to the 6% penalties assessed by the Commissioner of Internal Revenue against Ora E. Powell for substantial underestimation of estimated tax declared, plaintiff bears the burden of proof.

4. The deficiencies in income tax assessed by the Commissioner of Internal Revenue against Ora E.

Powell for the years 1937 through 1945 were due to fraud with intent to evade tax within the meaning of Section 293(b) of the Internal Revenue Code, and the 50% fraud penalties assessed against Ora E. Powell by the Commissioner of Internal Revenue for the years 1937 through 1945 were proper.

5. The 6% penalties assessed by the Commissioner of Internal Revenue for the years 1943 through 1945 against Ora E. Powell for substantial underestimation of estimated tax under Section 294(d)(2) of the Internal Revenue Code were not proper for the reason that Ora E. Powell, who had not filed any declaration for those years, paid the 10% penalties prescribed by Section 294(d)(1)(A) of the Internal Revenue Code, and was not required to pay, in addition, for an underestimate he never made.

6. Plaintiff is entitled to judgment in the amount of \$1,200.55, representing the 6% penalties improperly assessed by the Commissioner of Internal Revenue against Ora E. Powell under Section 294(d)(2) of the Internal Revenue Code, together with interest thereon as provided by law.

/s/ CHASE A. CLARK,

United States District Judge.

Affidavit of service by mail attached.

[Endorsed]: Filed December 26, 1956.



In the United States District Court  
for the District of Oregon

Civil No. 7837

GRACE M. POWELL, Executrix of the Estate of  
O. E. Powell, Deceased,

Plaintiff,

vs.

RALPH C. GRANQUIST, District Director of  
Internal Revenue,

Defendant.

### JUDGMENT

This cause was tried by the Court, sitting without a jury, on February 7, 1956. Appearances having been made by counsel for the parties, and the Court having considered the evidence and the arguments of counsel, now, therefore, it is

Ordered, Adjudged and Decreed that plaintiff recover of defendant \$1,200.55, together with statutory interest thereon.

The Court hereby certifies that there was probable and reasonable cause for the acts of defendant in demanding and collecting from plaintiff's decedent the penalties for the refund of which this judgment is entered.

So ordered this 21st day of December, 1956.

/s/ CHASE A. CLARK,

United States District Judge.

[Endorsed]: Filed December 26, 1956.

[Title of District Court and Cause.]

### NOTICE OF APPEAL

Notice of Appeal Is Hereby Given that Grace M. Powell, Executrix of the Estate of O. E. Powell, Deceased, the plaintiff herein, hereby appeals to the United States Court of Appeals for the Ninth Circuit from so much of the final judgment, as was entered in favor of defendant and against plaintiff, entered in this action on December 21, 1956.

/s/ ARTHUR D. JONES,

/s/ FREDERICK A. JAHNKE,  
Attorneys for Plaintiff.

[Endorsed]: Filed January 9, 1957.

---

[Title of District Court and Cause.]

### BOND FOR COSTS ON APPEAL

I, Grace M. Powell, Executrix of the Estate of O. E. Powell, Deceased, as principal, and National Surety Corporation, incorporated under the laws of the State of New York, and duly authorized and qualified to write and execute bonds and undertakings within the district of Oregon, as surety, and our personal representatives, successors and assigns, are bound to pay to Ralph C. Granquist, District Director of Internal Revenue, the sum of Two Hundred and Fifty Dollars (\$250.00).

The condition of this bond is that, whereas the plaintiffs have appealed to the United States Court

of Appeals for the Ninth Circuit by notice of appeal filed on January 9, 1957, from the judgment of the court entered on December 21, 1956, if the plaintiff will pay all costs adjudged against her if the appeal is dismissed or the judgment affirmed or such costs as the appellate court may award if the judgment is modified, then this bond is to be void; otherwise payment of this bond will be due forthwith.

/s/ GRACE M. POWELL,

Executrix of the Estate of O. E. Powell, Deceased.  
Plaintiff and Principal;

[Seal]

NATIONAL SURETY  
CORPORATION,

By /s/ ALICE T. BERKEMEIER,  
Attorney-in-Fact, Surety.

Countersigned:

PHIL GROSSMAYER CO.,  
Gen'l Agents;

By /s/ ALICE T. BERKEMEIER,  
Resident Agent.

Service of copy acknowledged.

[Endorsed]: Filed January 10, 1957.

In the United States District Court  
for the District of Oregon

No. 7837

GRACE M. POWELL, Executrix of the Estate of  
O. E. POWELL, Deceased,

Plaintiff,

vs.

RALPH C. GRANQUIST, District Director of  
Internal Revenue,

Defendant.

### TRANSCRIPT

This matter was tried before the Honorable Chase  
A. Clark, sitting without a jury, at Portland, Ore-  
gon, on February 7, 1956.

#### Appearances:

ARTHUR D. JONES, ESQ.,  
FREDERICK A. JAHNKE, ESQ.,  
Attorneys for the Plaintiff.

C.E. LUCKEY, ESQ.,  
United States District Attorney;  
EDWARD J. GEORGEFF, ESQ.,  
Assistant United States District Attorney;  
ALLEN A. BOWDEN, ESQ.,  
Special Assistant to the Attorney General;  
GILBERT E. ANDREWS, ESQ.,  
Special Assistant to the Attorney General,  
Washington, D. C.,  
Attorneys for the Defendant.

February 7, 1956—10 o'Clock A.M.

(Admission of certain counsel by the Court.)

The Court: If you Gentlemen are ready, you may proceed.

Mr. Jones: Your Honor, this is a case for the refund of Federal Tax penalties for the years 1937 to 1945, inclusive. There is no question as to the amount of tax due and owing that has been agreed upon by the parties to the case. Claim was filed for the fifty per cent fraud penalty—the twenty-five per cent penalty for failure to file a return and for the penalty for failure to file a declaration of estimated tax and pay the estimated tax. We are going to concede the twenty-five per cent penalty because we do not feel that we can sustain the burden of proving that this failure to file return was due to reasonable cause, we are also going to concede the ten per cent penalty for failure to file the declaration of estimated tax. The six per cent penalty for failure to pay the tax we are contesting. This is a pure question of law and I think it can be argued on briefs. Now, as to the fraud penalties, the burden of proof rests with the Government, so I think they should open their case at this time.

Mr. Andrews: If the Court please I would like to move to dismiss the Plaintiff's case under 41B with respect to the penalties involved. [3\*]

I understand that the Ohlinger case——

The Court: That happens to be my case.

Mr. Andrews: I know it is, Your Honor. I understand that in this circuit that the burden of proof is

---

\*Page numbering appearing at foot of page of original Reporter's Transcript of Record.

held to be on the Government as to the fraud issues. We are ready to proceed with our burden of proving that Ora E. Powell's failure to pay income tax through the years 1937 to 1945 was due to fraud with intent to evade tax.

Our first witness will be Mr. Cecil Tucker.

### CECIL TUCKER

called as a witness by the Defendant, after being first duly sworn, testifies as follows:

#### Direct Examination

By Mr. Andrews:

Q. What is your occupation, Mr. Tucker?

A. I work for the District Director of Internal Revenue.

Q. What is your title, if any?

A. Chief of Claims section.

Q. What are the duties of the Chief of Claims section?

A. I supervise the processing and scheduling of over-assessments and the initial reviewing of claims for refunds and abatements, the preparing of certificates of assessments and payments made on account and testifying on those assessments and payments in Court cases.

Q. Then your testimony is that you are the authorized representative of the District Director of Internal Revenue to testify in this case? [4]

A. Yes, sir.

Q. I hand you document dated July 5, 1955, pur-

(Testimony of Cecil Tucker.)

porting to be signed by R. C. Granquist and headed "certificate of assessments and payments"; will you identify that document, please?

A. This is form 899 certificate of assessments and payments covering the years 1937 through 1945 for O. E. Powell.

Q. Can you tell from an examination of that form the dates on which tax returns were first filed by Ora E. Powell?

A. I can tell the year in which they were filed, yes.

Q. In what year was the return for 1937 filed?

A. That was in the year 1951.

Q. And for the year 1938?

A. During 1951.

Q. For the year 1939? A. During 1951.

Q. And for the year 1940?

A. During 1951.

Q. And for the year 1941?

A. During 1951.

Q. For the year 1942? A. During 1951.

Q. For the year 1943? A. During 1951.

Q. For the year 1944?

A. The first return there was filed September, 1948. [5]

Q. And for the year 1945?

A. September, 1948.

Q. Can you tell from looking at that form the date on which Mr. Powell filed a declaration of estimated tax for the year 1943?

(Testimony of Cecil Tucker.)

A. There is no record of an estimated tax filed for 1943.

Q. And for the year 1944 with respect to estimated tax?

A. There is no record of an estimate filed for 1944.

Q. And for the year 1945?

A. There is no record of an estimate filed for the year 1945

Mr. Andrews: No further questions.

Mr. Jones: No questions.

Mr. Andrews: At this time I would like to offer in evidence as Defendant's exhibit 1, the Certificate of Assessments and Payments form 899.

Mr. Jones: I have no objection although I haven't had an opportunity to examine it.

The Court: It may be admitted.

### CARL P. ARMSTRONG

called as a witness by the Defendant, after being first duly sworn, testifies as follows:

#### Direct Examination

By Mr. Andrews:

Q. By whom are you employed, Mr. Armstrong?

A. I am employed by the United States National Bank of Portland.

Q. What is your position with the Bank? [6]

A. Assistant Manager of the Ladd and Bush Salem Branch of the United States National.



(Testimony of Carl P. Armstrong.)

Q. For how long have you been with the Bank?

A. You mean with the Banking fraternity?

Q. No, sir—how long have you held your present position?

A. The present position, I have held that since 1949.

Q. What was your position prior to that time?

A. I was office manager of the State Tax Commission from the period of September, 1937, to September, 1949.

Q. What was your title with the Commission?

A. In the final analysis I was the office manager of the Portland Office of the State Tax Commission.

Q. The Oregon State Tax Commission?

A. That's right.

Q. Did there come a time in the Court of your official duties when you contacted Mr. Ora E. Powell?

A. Yes, sir.

Mr. Jones: I object to this; I don't see how it has a relevancy to the case. They are talking about State Income Tax now.

The Court: I will let him answer—it is a Court matter. I don't know just where it would be material and I will not consider it if I don't find later that it is material.

Q. What was the date of that initial contact, Mr. Armstrong?

A. The initial contact was sometime prior to September, 1938. [7]

Q. What were the circumstances under which the contact was made?

(Testimony of Carl P. Armstrong.)

A. The State of Oregon, during that period, were making a complete investigation of all County records regarding taxpayers that had not filed income tax returns. I was assigned to the Clackamas County area and made the investigation of the County records during the Fall of '38.

Q. What was the nature of your contact with Mr. Powell?

A. The nature—the County records, upon our investigation of the assessment of personal property, the information secured was checked with the State Tax Commission in a determination of getting to the taxpayers that had not filed income tax returns.

Q. Is it your testimony that Mr. Powell had not at that time filed state income tax returns?

A. That is true.

Q. What events led up to your contact with Mr. Powell?

A. The information secured from the Clackamas County records, as I indicated, was checked with the records of the State at Salem and we found that it was necessary to write him a letter requesting his presence in the temporary office established at Oregon City, affiliated with the Sheriff's office.

Q. What took place at your conference with Mr. Powell?

A. A letter was sent to Mr. Powell for him to appear regarding his tax liability. [8]

Q. Did he appear?

A. Yes, he appeared and indicated that he had records, and we explained to him his responsibility in filing his income tax returns.

(Testimony of Carl P. Armstrong.)

Q. Is that State Income tax returns or Federal?

A. State Income tax returns.

Q. Did you say anything to him about Federal Income tax returns?

A. Yes; upon completion of our investigation of the records that he had for the years 1935 and '36 and also '37, we indicated to him at that time that he also had a tax liability to the Federal Government. This procedure was followed in all cases of our investigation because of the method used by the State Tax Commission, which was to familiarize the taxpayer with their responsibility and also to indicate to them the responsibility they might have to the Federal Government in that respect.

Q. Mr. Armstrong, I hand you document marked "defendant's exhibit 2" for identification, under the seal of the Oregon State Tax Commission, purporting to be the income tax return filed with the State of Oregon by Mr. Powell for the years beginning with 1935; do you recognize those returns?

A. Yes, I do.

Q. Did you have anything to do with the preparation of those returns? [9]

A. Yes; my associate and I called upon Mr. Powell and looked over his records.

Q. Did you have anything to do with the preparation of those returns?      A. Yes.

Q. What did you have to do with the preparation of the returns?

A. The preparation of the returns—I discussed with him his responsibility and also went into his

(Testimony of Carl P. Armstrong.)

records and even though the writing here was made by my associate at that time, my name appearing, however, as responsible for the submission of the return and that the records were investigated by me as well as my associate.

Q. Did Mr. Powell then have records available for the years 1935 and 1936?

A. Yes, as they were. They were records that we were able to determine his tax liability.

Q. And were there records available for the year 1937?

A. No, they were not.

Q. Did Mr. Powell make any explanation for his failure to have records available for 1937?

A. His records—he didn't have any records available for 1937 upon the preparation of this return so as to bring it into a correct condition. We arbitrarily increased his net income for 1937 based upon an increase of ten per cent over that of 1936, so as to clear our [10] records for the liability for the years 1935, '36 and '37.

Q. Did you ever have any contact with Mr. Powell or anyone acting for him after that contact in 1938?

A. Other than the gentleman—one of the accountants that appeared with some of the delinquent returns and presented them to me in the Portland office.

Q. What was the name of the accountant?

A. Willoughby.

Q. Was he the accountant for Mr. Powell?

A. He represented himself to be.

Q. That was in 1942?

A. Yes, that was in 1942, June of '42.

(Testimony of Carl P. Armstrong.)

Q. Do you know who made out those returns for the years 1938 and '39?

A. Mr. Willoughby filed those returns, I am positive.

Q. At any time in any conversations with Mr. Powell did he ever indicate that he was unaware of the requirement for filing either Federal or State income tax returns?

Mr. Jones: I object to that—will you please restate the question?

(Question read by reporter.)

Mr. Jones: I beg your pardon; I withdraw the objection.

Q. With the information we had it was very evident that he didn't realize his responsibility and for that reason he was enlightened on the law—

Mr. Jones: I object to that as not being responsive to the question.

The Court: Yes, that's right; it is not responsive.

Q. Did you understand the question, Mr. Armstrong?

A. Perhaps not; will you repeat that again.

Q. My question was: Did Mr. Powell at any time ever say anything to you which indicated that he was ignorant of the legal requirements for filing either State or Federal income tax returns?

Mr. Jones: I object to that, your Honor, as a leading question.

The Court: It is leading but he may answer it and he may answer it yes or no.

(Testimony of Carl P. Armstrong.)

A. I would say no, he wasn't familiar.

Q. Was there an answer to that question?

A. Well, I didn't quite get that—may I make a statement?

The Court: Well, I think your counsel—

Mr. Andrews: I will withdraw the question. You may cross-examine.

Mr. Jones: At this time I would like to make a motion that his testimony be stricken as it is immaterial. We are not delving into the State tax liability here and his testimony is immaterial and irrelevant. [12]

The Court: I will not rule on your motion at this time but will take it under advisement.

### Cross-Examination

By Mr. Jones:

Q. Mr. Tucker, were you aware or did you ask Mr. Powell directly about his responsibility for filing a State income tax return for the years in question? A. Yes, he was asked that.

Q. And what was his answer?

A. Well, he evaded the filing of state income tax returns and it was very evident from the information that I had that it justified the investigation and his appearance when requested.

Q. What character was this evasion, Mr. Tucker—you speak of evasion; what do you mean by evasion?

A. Well, the fact that he didn't prepare income tax returns that justified the filing of returns.

(Testimony of Carl P. Armstrong.)

Q. That was your own conclusion, that is not any statement that he made to you?

A. I think that every taxpayer should file an income tax return if the information we had justified the filing of a tax return.

Q. The question was: Were you aware or did Mr. Powell make any statement to you as to his knowledge of his obligation to file a tax return?

A. Well—— [13]

Q. Could you answer that yes or no?

A. Certainly with the information we had, it justified the filing of a return.

Q. (By Mr. Jones): Your Honor, will you direct the witness to answer the question?

The Court: Yes; I think, Mr. Witness, that you better try to answer the question a little more directly.

A. Will you restate your question?

Q. Were you at any time, let me state that again. During the course of your investigation, did Mr. Powell make any statement to you that would indicate to you that he had knowledge of his responsibility of filing a return for the period under question? A. Well, he didn't file any returns.

The Court: It might be helpful, Mr. Witness, if you would just tell what the conversation was and what he said and what you said to him.

Q. He responded to the request to appear at the office there and the information that I had I went over with him in detail and indicated to him that he should file income tax returns, that the information justified the filing of income tax returns.

(Testimony of Carl P. Armstrong.)

The Court: What did he say to you?

A. He indicated to me that his attitude at that time was that of no responsibility to file any income tax returns. When I explained to him, after the investigation, I went [14] further to inform him that he should file his Federal return as well as the State return. I explained the situation to him.

Q. During your investigation for the State Tax Commission in this regard, what was the form of your investigation?

A. Well, in the investigation of the County records we had the assessments of personal properties and the data that we ran against the Federal records as well as a report of our "99" which was rental income received from the Union Oil Company of California, indicating an amount—is it necessary to state the amount?

Q. If you have it.

A. Indicating \$1125.00 rental income, as well as the information that I secured from the County records that justified him being called in and asking why he hadn't filed State income tax returns.

Q. He made no direct statement to you or admit to you that he had a duty to file those returns?

A. I cannot recall what was said other than the fact that he hadn't filed.

Q. As a matter of fact, you don't recall what he said about those returns then?

A. Other than his attitude toward the filing of the income tax returns.

Mr. Jones: That's all.



(Testimony of Carl P. Armstrong.)

Redirect Examination

By Mr. Andrews:

Q. Mr. Armstrong, we have talked about the receipt of interest payments from the Union Oil Company of California—

A. Rental payments.

Q. We have talked about the receipt of rental payments from the Union Oil Company of California, is that what is indicated by the first slip on Defendant's Exhibit 2 marked for identification?

A. That is the exhibit on the year '35.

Q. Your answer is yes? A. Yes.

Q. Is it your testimony then that Mr. Powell filed his income tax return with the State of Oregon after the investigation made by the Oregon State Tax Commission? A. Yes, sir.

Q. And for what years?

A. The returns I prepared were for the years 1935, '36 and '37.

Q. What about the years 1938 and '39, was the filing made on time? A. No, they were not.

Q. What led up to the filing of returns for the years 1938 and 1939 by Mr. Powell?

A. A letter from the Chief Auditor in the Salem Office informing him of not filing what we call a master file checking—informing him that he had not filed his 1938 return. [16]

Q. And in what year was that letter sent?

A. That letter was sent in '42.

Mr. Andrews: No further questions.

(Testimony of Carl P. Armstrong.)

Recross-Examination

By Mr. Jones:

Q. You didn't talk to him directly about his return for 1938 and '39, is that correct?

A. I did not talk to him personally about the 1938 and '39, other than his accountant brought it to my attention at the time I was in charge of the Portland Office.

Q. You have——

A. I did assess the penalties.

Q. You have no knowledge, no personal knowledge of his 1938 and '39 tax returns, the preparation of them?      A. No, I do not.

Mr. Jones: That's all.

Mr. Andrews: At this time I would like to offer in evidence Defendant's Exhibit 2 for identification as Defendant's Exhibit 2.

Mr. Jones: Your Honor, I object to the introduction of this exhibit in evidence because I don't think they are properly attested to as required by Section 1739 of the Judicial Code.

(Remarks of counsel on the objection reported and not transcribed.) [17]

The Court: It may be admitted.

HAROLD PARSONS

called as a witness by the Defendant, after being first duly sworn, testifies as follows:

Direct Examination

By Mr. Andrews:

Q. What is your occupation, Mr. Parsons?

A. Special agent, Internal Revenue service.

Q. For how long have you been a special agent?

A. Since July 1, 1945.

Q. For how long have you been employed by the Internal Revenue service?

A. Since November, 1942.

Q. What are your duties as a special agent?

A. Among other things we gather evidence for criminal prosecutions in tax evasion cases.

Q. Did there come a time when you were called upon in the course of your official duties to contact Mr. Ora E. Powell?

A. Yes, sir.

Q. What was the date of that contact?

A. Well, I was assigned to the investigation of the case of Ora E. Powell in June, 1946, and the investigation was extended until October 31, 1947.

Q. What was the nature of that investigation?

A. Charge of failure to file income tax [18] returns.

Q. What was the nature of your investigation?

A. Gathering evidence to determine the tax liability of Ora E. Powell.

Q. How did you go about determining that tax liability?

(Testimony of Harold Parsons.)

A. Among other things examined the county records of Multnomah County, Washington County, Marion County and Clackamas County, the deed and mortgage records to determine the purchase and sale of real estate by Ora E. Powell.

Q. Why didn't you go to Mr. Powell's records and find that information?

A. We requested records from Mr. Powell and he stated that he had not kept records of his real estate transactions.

Q. Did he state whether or not he had kept records during the period in issue, 1937 to 1945?

A. That was the only period for which we requested records, the period under investigation.

Q. Did he state that he did or did not keep records during that period?

A. That he did not keep records during the period we were investigating.

Q. Was your investigation confined solely to the ultimate computation of the gain or loss of the real estate transactions of Mr. Powell's?

A. No, we had investigated as to the reason why he had not filed returns. [19]

Q. How long did your investigation take?

A. From June of '46 to October of '47, probably during that time we would spend between thirty and forty working days.

Q. Did Mr. Powell ever make any documents or information available to you?

A. There were some real estate sales on contract, and when we would discover such sales we would

(Testimony of Harold Parsons.)

request that he bring in the contracts so that we could determine the amount of payments on the contract and the interest. When he was specifically asked for a certain contract he would bring it in.

Q. Aside from the contracts specifically requested one at a time, was there any documents or information made available to you by Mr. Powell?

A. No, not to me.

Q. Did Mr. Powell ever state to you at any time his reason for failure to file income tax returns for the years 1937 to 1945?

A. Yes.

Q. What reasons did he state?

A. On at least two occasions he made the statement that he was not in sympathy with the administration and did not like the way the Government was run and did not believe in paying income taxes.

Q. Do you know the dates of those statements?

A. I know the date of one statement. It was—I believe [20] I can remember—no, I wouldn't without referring to my notes. We are required to keep a diary and I have those dates available if we have occasion to look them up.

Q. Do you have the diary here?

A. I haven't it here with me, however, I have excerpts from it and I could obtain the date.

Q. Do you have that with you?

A. I have it in my brief case.

The Court: You may get it.

A. That was on June 10, 1947.

Q. Was that the first or the second time?

(Testimony of Harold Parsons.)

A. That was the second time.

Q. When was the first statement made?

A. Some time prior to that, I don't know just the date.

Q. Do you know the year?

A. I think it was earlier in 1947.

Q. Did Mr. Powell ever state any other reason for his failure to file income tax returns?

A. Yes, he said it was because of ill health and inability to obtain the services of a competent book-keeper and that he hadn't kept records.

Q. Did Mr. Powell ever indicate to you at any time that he was unaware of the legal requirement to file income tax returns?      A. No.

Mr. Andrews: You may cross-examine. [21]

#### Cross-Examination

By Mr. Jones:

Q. Did Mr. Powell state to you the nature of his ill health, Mr. Parsons?

A. Yes; he said he was suffering from diabetes.

Q. Did you ever make a direct request of Mr. Powell to bring all his books and records into the Internal Revenue Service?      A. Yes.

Q. Did he bring those available records in?

A. He said he didn't have records. At no time did he bring in any records aside from the few contracts that were specifically requested.

Q. Did he say that he didn't have any books and records—you were referring to formal books and records, were you?      A. That's right.

(Testimony of Harold Parsons.)

Q. You didn't request him to bring in his cancelled check and bank statements and records of that nature, invoices and such?

A. My work was not audit work. A revenue agent attended to the audit work, so I would not and did not request cancelled checks or bank statements.

Q. Then, in other words, you made no request for him to bring in what we might term subsidiary records to a formal set of books?

A. At more than one time we requested him to bring in any records that he had, any records whatsoever that would assist in determining the amount of his income. [22]

Q. Did you make a specific designation to him of what these records should consist of, or make a specific request of him of the nature of the records you wanted?

A. I don't know that I at any time listed all the possible records that he might have, it was specifically requested that he bring in any records pertaining to his income.

Q. Isn't it quite possible that he thought you were referring to a formal set of books and records?

Mr. Andrews: I object to that, obviously——

Mr. Jones: I will withdraw it.

Q. Then, for all you know, these records might have been brought in for another person who made this audit in this case, is that correct?

A. I understand that cancelled checks and bank

(Testimony of Harold Parsons.)

statements were made available but I did not examine them.

Q. That is the point I wanted to establish—he made no direct refusal to bring in what records he had, to you?      A. No, sir.

Q. In the course of your investigation of Mr. Powell's affairs, did you find any direct attempt by him to cover up transactions?

Mr. Andrews: I object to that on the ground that it calls for a legal conclusion.

Mr. Jones: I will rephrase the question. [23]

The Court: Yes, that could be determined from the facts.

Q. Mr. Parsons, did you ever find any evidence of Mr. Powell having destroyed records?

A. No.

Q. Did you find any evidence of false records?

A. No.

Mr. Jones: That's all, your Honor.

### Redirect Examination

By Mr. Andrews:

Q. In respect to Mr. Powell's statement that he was suffering from diabetes, did he indicate when he was suffering from diabetes, was that at the time of your investigation?

A. He indicated that it had been over a period of years.

Q. For how long?      A. I don't recall.

Q. Do you know the nature or the kind of ac-



(Testimony of Harold Parsons.)

tivities carried on by Mr. Powell at the time of your investigation?

A. Yes, he was dealing extensively in real estate, both purchasing and selling real estate and renting real estate and a part of the time operating a number of gasoline service stations.

Q. Was he leading, would you say, an active business life? A. Very active.

Mr. Andrews: That's all.

Mr. Jones: No further questions. [24]

DANIEL S. FORSBERG

called as a witness by the Defendant, after being first duly sworn, testifies as follows:

Direct Examination

By Mr. Andrews:

Q. What is your occupation, Mr. Forsberg?

A. Internal Revenue Agent.

Q. For how long have you been an Internal Revenue Agent? A. November, 1953.

Q. What was your position prior to that time?

A. Deputy collector.

Q. When did you become a deputy collector?

A. July, 1944.

Q. What are the duties of a deputy collector?

A. I start out with warrants in distraint, then into office audits, auditing tax returns right in the office and then I was sent out on field investigations to determine tax deficiencies and failure to file returns.

(Testimony of Daniel S. Forsberg.)

Q. Did there ever come a time, Mr. Forsberg, in the course of your official duties when you contacted, as deputy collector, Mr. Ora E. Powell?

A. Yes.

Q. What was the date of that contact?

A. I sent Mr. Powell a letter——

Q. What was the date of that contact?

A. January, 1946. [25]

Q. What were the circumstances under which that contact was made?

A. During those years we had received—the Treasury Department received from Banking institutions information reports concerning large currency transactions with their clients or others coming into the banks. Those, in turn, were passed on to our service and passed on or distributed to the various deputy collectors for investigation. One such information report came across my desk in regard to Ora E. Powell, and based on that I sent a letter to Mr. Powell in January of 1946 asking him to come in to this office in regard to his income tax matters and to bring along copies of his Federal Income Tax returns for the past several years.

Q. First I will ask you what the nature of the transaction was that caused you to investigate—in other words, what currency transaction was there which came to your attention?

A. Mr. Powell withdrew \$6,000.00 in cash from his account in the U. S. National Bank.

Q. Now, on the occasion of your first contact

(Testimony of Daniel S. Forsberg.)

with Mr. Powell, your first personal contact, what did he say and what did you say?

A. Mr. Powell came in after the filing period in March—he had been out of State—he didn't have his copies [26] of returns with him and he advised me at that time that he had not filed income tax returns since 1936.

Q. Did you request Mr. Powell to furnish you with any records?

A. My next question then was to furnish me with the books and records by which I might determine whether he had a tax liability or not.

Q. Did Mr. Powell produce such books and records?

A. He advised me that he had never kept any books or records during that period of time.

Q. What was the next step in your investigation?

A. Then I asked Mr. Powell regarding bank statements and cancelled checks. He had an account at the First State Bank of Milwaukee and at my request he produced cancelled checks and bank statements for all years in question. Checks were missing for the first half of 1937 only.

Q. And will you proceed with a brief summary of the type of investigation you conducted?

A. In the absence of records—I will have to divide the investigation into two periods. For the years 1937 to 1941, inclusive, Mr. Powell owned and operated several gasoline service stations. To determine the taxable profit from that operation I

(Testimony of Daniel S. Forsberg.)

used bank deposits, excluding all non-income items, as total receipts and I deducted cancelled [27] checks that were established to be ordinary and necessary business expenses, plus giving him an allowance for depreciation on known buildings and equipment. That was the basis for my finding of his taxable income for the period 1937 to 1941, inclusive. Now, in the years 1942 to 1945, inclusive, Mr. Powell leased these stations to his two sons, Lee G. Powell and Vincent O. Powell, and received from them rental income. Further than that, he had, at various times, during that period nineteen different properties that he rented, and also during that time he made in excess of thirty real estate sales, farms and residences, and also he had interest income on contracts and commissions from the sale of real estate. Now, for that income for that period I went through the books of Lee G. Powell and Vincent O. Powell to determine the rental income they had paid their father for those service stations and I also checked that with the income tax returns that they had filed. It agreed and I used that as his income for the service stations. It was necessary in view of the lack of records and the failure to obtain the deeds, mortgages and contracts to assist us to go to the County records of Multnomah, Clackamas, Washington, and Marion Counties to establish what property, if any, the taxpayer had owned during that period and what properties he had sold. From the tax rolls we went to the addresses of [28] various people and inter-

(Testimony of Daniel S. Forsberg.)

viewed them, checked with people that had bought, people that had rented and checked their contracts where they were available, to determine the profit on the sale of real estate, the rental income and the interest income on contracts. Mr. Powell obtained a broker's license in January of 1943—a real estate broker's license and he received commissions in his own right, also commissions working for other real estate brokers and I based the commissions taken on an estimate given to me by Mr. Powell, as far as the commissions were concerned. I knew part of them from the actual wage slips that he received. So then we determined real estate sales, the profits, the rents—rental income, interest on contracts from an extended investigation necessary to contact the people involved in those transactions.

Q. What was the total amount of taxable income which you computed for the years 1937 to 1945?

A. In excess of \$118,000.00.

Q. Now, you stated that you determined the income from the gasoline stations owned by Mr. Powell for the years 1937 to 1941 by analyzing the bank deposits and subtracting certain cancelled checks. Was this method the one subsequently used as a basis for the deficiencies in income tax asserted by the Commissioner of Income Revenue?

A. Later the taxpayer protested my findings and I believe [29] that during that period the next examining officer used deposits and—

Mr. Jones: I object, your Honor, to this line of

(Testimony of Daniel S. Forsberg.)

testimony, testifying as to what someone else did. He cannot testify to acts of his successor.

The Court: That would seem to be true.

Q. I would like to limit the question, your Honor, to this: Was the figure which you arrived at by using the bank deposits and cancelled checks method for the income from the gas stations for the period of 1937 to '41, was that the same figure that was ultimately used by the Commissioner of Internal Revenue in assessing the deficiency in income tax?

A. No, sir.

Q. Did the taxpayer agree that your method provided an accurate computation of income from the gas stations?

A. He had nothing to say on that; he voiced no opinion either way.

Q. You said something about a protest, who was the protest made by?

A. To me he made no such statement at the time.

Q. Do you, of your own knowledge, know whether any protest was made to anyone with respect to that method which you used?

A. He took his legal rights and made a protest, yes, against the findings that I had made. [30]

Q. How long did your investigation take, Mr. Forsberg?

A. My part of the investigation, and my time only, was in excess of twenty-seven working days. That was due, in part, to the fact that we had all of this ground to cover and all of these people to

(Testimony of Daniel S. Forsberg.)

interview and it took considerable time to get all this information together.

Q. Aside from the cancelled checks and the bank statements, what documents and information, if any, was made available to you by Mr. Ora E. Powell?

A. He made available to us specific contracts upon our specific request, after it became apparent that we had all the information regarding that particular sale.

Q. Did you ever make any general request for contracts or information?

A. Yes, sir, we certainly did.

Q. And what was his response to that request?

A. That he kept no such records and that he had no such records, and the general statement to the effect that he didn't see why he should, more or less, jeopardize himself in any way. As far as getting contracts and deeds and that, it became evident that he had them all the time but we were not given them until we specifically asked for each one as we discovered them.

Q. Did Mr. Powell ever state to you, at any time, any reason for his failure to file income tax returns for the years 1937 to 1945? [31]

A. Yes.

Q. What was the reason he gave?

A. At least on two occasions and in the presence of the joint examining special officer, Parsons, the taxpayer said that he didn't like the present administration. He didn't believe in the way the Coun-

(Testimony of Daniel S. Forsberg.)

try was being run and he didn't believe in paying income taxes, and he was strongly thinking of getting his things gathered together and moving out of the country and going to South America where he didn't have to pay taxes.

Mr. Jones: I move that latter part be stricken as not responsive——

The Court: It may stand.

Q. Did he ever state any other reason?

A. To me, he gave one other reason—that he didn't have the time and, therefore, neglected to do it.

Q. Did he ever say anything to you about being too sick to file?      A. No, sir.

Q. Did he ever say anything to you which indicated to you that he did not know of the requirement for filing Federal income tax returns?

A. No, sir.

Q. At the time of your investigation, was Mr. Powell leading an active or an inactive life?

A. Very active. [32]

Q. Very active?

A. Yes, in fact most of his income came in the latter years of the investigation. His greatest profit was from the years 1942 to '45.

Mr. Andrews: I have no further questions.



(Testimony of Daniel S. Forsberg.)

Cross-Examination

By Mr. Jones:

Q. It is true that when you requested Mr. Powell to furnish what records he had such as checks, bank statements and so forth, he brought those forth willingly, did he, for that period?

A. Upon my request for bank statements and cancelled checks he produced them, yes, sir.

Q. And upon your request for specific deeds he produced them, is that correct?

A. On our specific request, yes, sir.

Q. He never refused to produce any document you asked him for, is that correct?

A. Not when we would identify what we wanted, no, sir.

Q. You made specific requests upon Mr. Powell that he furnish books and records, is that correct?

A. Yes, sir, I did.

Q. And he made the statement that he had no formal books or records?

A. He made the statement that he had not kept any books or records on his income for that period we had in question. [33]

Q. He did make the statement to you that he had had trouble getting professional help and that he didn't have time to do it, is that correct?

A. He made no statement regarding professional help to me. His statement was, as I have indicated, that he didn't have time—that he hadn't gotten

(Testimony of Daniel S. Forsberg.)

around to it and that he had neglected to do it, that was his statement to me.

Q. He made no statement regarding the possibility of hiring someone else to do it?

A. Not to me.

Q. Now, when you went through the books of Mr. L. G. Powell and V. O. Powell to ascertain the amount of these payments made by his sons to Mr. Powell, were you able to check those into his bank account?

A. I didn't trouble to do that, I didn't work with his bank account in those years, 1942 to 1945, inclusive. I took specific items. They showed the deductions on their books and they showed it on their return and that was good enough for me.

Q. Now, in your report of your investigation, did you find that Mr. Powell had destroyed any records? A. He said he kept no records.

Q. What I was referring to was cancelled checks and the normal subsidiary records that you find in the taxpayer's possession. [34]

A. The cancelled checks, as I stated before, were all there, and the bank statements except for the first half of 1937, when the checks were missing.

Q. Did you find any evidence of any attempt on his part to alter any of these records?

A. There was no alteration of any of the bank statements or the cancelled checks that I examined; no, sir.

Q. Did you find any attempt on the part of Mr.

(Testimony of Daniel S. Forsberg.)

Powell to alter or change or conceal any real estate contracts?

A. He certainly never came forward to give us the information that we asked for.

Q. That isn't the question that I asked. Did he make any attempt to conceal or alter these?

Mr. Andrews: I object to that insofar as he is being asked concerning an attempt to conceal, there could be many acts that could be regarded by one person as an attempt to conceal and not by another person.

The Court: I think that is a matter for the Court to decide from the evidence.

Q. Was there any attempt to conceal any of these real estate transactions, on the part of Mr. Powell?      A. When I asked——

The Court: I think you should just bring out the facts—there was an objection to this same question and I sustained it. [35]

Q. Were there any alterations on these real estate contracts?

A. The contracts that were given to us, that we requested seemed to be in good order.

Q. So in your investigation you found no destruction of records, and no alterations of subsidiary records and these real estate contracts which you stated?

A. The contracts were in order that we saw. The bank statements and cancelled checks except for the checks for 1937—the first half—were in order, there was no destruction of those and nothing where I

(Testimony of Daniel S. Forsberg.)

could see that they had been tampered with in any way.

Q. You were satisfied at the time of this investigation—let me put the question this way: Did you go to the bank and request any evidence of these checks from the bank from their records?

A. I had no need to. I already had his cancelled checks.

Q. I mean for the first part of 1947?

A. You mean '37?

Q. Yes, '37.

A. No, I didn't go to the bank and ask for those, sir.

Q. Then you were satisfied that these checks had been inadvertently misplaced and that there wasn't any attempt to conceal them?

Mr. Andrews: I object to that as calling for a conclusion. He certainly doesn't know what checks were inadvertently misplaced. [36]

The Court: Yes, that's right.

Q. Did Mr. Powell account for the absence of the checks for the first part of 1937 at the First State Bank of Milwaukie?

A. They never were given to me, sir.

Q. Did you make any attempt to secure them, Mr. Forsberg?

A. I asked Mr. Powell for them and the second time he said that he would look for them, as I recall that. I wasn't disturbed in any way. I had sufficient checks and they were missing and I took it for granted that nobody could find them.

(Testimony of Daniel S. Forsberg.)

Q. In other words, you were satisfied in your own mind that they were unavailable?

A. Yes, sir.

Q. During the course of your investigation, did you find that Mr. Powell had filed Federal income tax returns prior to the taxable year 1937?

A. Yes.

Q. For what years?

A. Delinquent returns were received in the collector's office in May, 1937, for the years 1933, 1934, '35 and '36.

Q. Do you recall the amount of the taxable net income on those returns?      A. I do not.

Q. Your investigation of these returns filed prior to 1937, did your investigation disclose whether those were [37] voluntarily filed?

A. I think the records at that time on that investigation were missing, so we don't know whether Mr. Powell brought those in or whether our department picked them up, but that they were delinquent there is no doubt.

Q. You couldn't testify positively whether he had filed those on a request from the Internal Revenue Service or filed them voluntarily on his own motion?

A. No, sir; there is nothing in the evidence to date that would show us those facts.

Q. You testified that you worked twenty-seven days—working days reconstructing the data on the computation of the net taxable income, is that correct?

(Testimony of Daniel S. Forsberg.)

A. In excess of 27 working days, my time only.

Q. And that was reconstructing the data for the taxable years 1937 through 1945? A. Yes, sir.

Q. In other words, your time was spent in checking the records of the various counties in the County Courthouses to establish these mortgages and the like and checking his bank statements and checking the books of L. G. Powell and V. O. Powell, is that right?

A. A copy of my "daily" will indicate that I made numerous contacts with individuals trying to trace these various transactions of rental income and sales of property, besides contacts with Lee G. Powell and Vincent O. [38] and their books, besides contacts with real estate firms regarding commissions, beside checking county records to no end.

Mr. Jones: That's all.

### Redirect Examination

By Mr. Andrews:

Q. Did Mr. Powell ever voluntarily make any documents or information available to you?

A. Voluntarily, no, sir.

Q. Then it was always at your specific request that documents or information was furnished?

A. Yes, sir.

Q. What would Mr. Powell require from you before he would go to his records and pull out any particular contract specified by you?

A. Well, we would tell him of the property and

(Testimony of Daniel S. Forsberg.)

the party he sold it to and told him that we would like to see the contract if he had it available. We would always identify what we wanted.

Q. Then the information which you would already have was the piece of property involved and the name of the purchaser? A. Yes, sir.

Q. Anything about the price?

A. We might have the price and we might not.

Q. And what about the date of transfer?

A. Well, on the contracts, you see, most of the contracts [39] were not recorded, and it took some uncovering to determine who had bought that property. In some instances the people didn't seem to have a copy of the contract. Once we were able to determine that a sale actually existed and we asked him specifically about it he brought it forward to us.

Q. Your testimony is that the only time he produced any document showing a sale of any real property was when you had the name of the party to the transaction, the date of the transaction and the particular piece of property involved?

A. Yes, I asked him when I found out about these real estate deals, to bring in his deeds and his contracts and he didn't do it, only after we uncovered them right out one by one did we get them.

Mr. Andrews: That is all, Mr. Forsberg.

(Testimony of Daniel S. Forsberg.)

Recross-Examination

By Mr. Jones :

Q. But he never at any time refused to produce a document that you asked for specifically?

A. No, sir; except that he, in a general way, did. He never brought these in when I asked him for all the deeds and contracts he had. He just never replied to us, he never came in with the information.

Q. But you were able to determine from other evidence the existence of the contract? [40]

A. In some instances, yes. We might not have the information and the contract that was brought in assisted us in that. I might say that whereas I spent twenty-seven working days on this case, if that information had been given to me or made available to me in working on the case, I could have probably done it in two weeks.

Q. That is just your opinion?

A. Well, I work with that stuff pretty regularly, I should know pretty well what it takes to do it.

Q. But you were able to identify the contracts you asked for from other records, is that correct?

A. Yes, sir.

Mr. Jones: No further questions.

The Court: We will take a recess for fifteen minutes.



February 7, 1956—11:30 A.M.

EDWARD A. MAIER

called as a witness by the Plaintiff, after being first duly sworn, testifies as follows:

Direct Examination

By Mr. Andrews:

Q. What is your occupation, Mr. Maier?

A. I am a certified public accountant.

Q. Are you in business for yourself or are you employed by some organization?

A. I am in business for myself—a [41] partnership.

Q. How long have you been in business for yourself?      A. Since the first of this year.

Q. What was your occupation prior to the first of the year?

A. I was an Internal Revenue Agent.

Q. In the course of your official duties, Mr. Maier, did you ever have occasion to contact Mr. Ora E. Powell?

A. I had contact with the case of Ora E. Powell. I do not believe that I actually contacted Mr. Powell.

Q. What was the date that you entered the Powell case?

A. It was some time in 1950. Early in 1950.

Q. What were your duties in connection with that investigation?

A. Mr. Powell had protested the findings of the

(Testimony of Edward A. Maier.)

prior examination and it was my duty to make a re-examination.

Q. What was the result—first, what were you re-examining?

A. Re-examining the records that were available or that were made available at this time.

Q. How did you go about making that examination?

A. Another certified public accountant was handling the case at that time and I made contact with him. He had certain records available at his office which I then proceeded to examine.

Q. What records were available at that time?

A. Principally they were work sheets that had been made up by this accountant at that time and the cancelled checks and contracts and so forth that the taxpayer had. [42]

Q. Do you know of any reason for the certified public accountant's co-operation at that time?

A. I know that in view of the protest, that the taxpayer had to make—well the taxpayer had to come forward and give some help in making a determination.

Q. Can you think of any other reason for the introduction of a certified public accountant at that time?

Mr. Jones: We object to that question, your Honor. He is not stating a fact—

The Court: You may ask if he knew of any other reason.

Q. Do you know of any other reason for this co-

(Testimony of Edward A. Maier.)

operation of the certified public accountant at that time?

A. Due to the fact, I believe, that there had been a trial of the taxpayer on the issue of wilful failure to file return.

Q. Was that a civil or criminal proceedings, do you know? A. I think it was criminal.

Q. Do you know the outcome of that proceedings?

A. I know in the record it shows that the taxpayer—

Mr. Jones: I object, your Honor, he is not testifying from direct knowledge.

The Court: There is a statement of facts in the pretrial order.

Q. Had you finished your answer?

A. I know that in the records that were available to me [43] showed that the taxpayer had either entered a plea of guilty or had been found guilty. I think one of the provisions was that he co-operate in finding a determination of the correct tax liability at that time.

Q. At that time, then, a certified public accountant was engaged by the taxpayer to co-operate with you? A. That is my understanding of it.

Q. Did you ever ask either Mr. Powell or the accountant for any books, any ordinary books and records?

A. I don't recall that I ever asked for any standard books, as we know them. I think the record shows that everything that was available to me

(Testimony of Edward A. Maier.)

—that in them there was no standard books available, no formal books.

Q. How much time did you spend on your examination?

A. I don't actually remember. I would think that it was probably about a week or perhaps a day or two—not over a week.

Q. What changes, if any, did you make in the prior examination report?

A. The taxpayer had available at this time, I believe, certain records which he did not have prior thereto, or had not made them available prior to this time, which were to his benefit insofar as they reduced the tax liability that had been set up.

Q. What was the over-all taxable income for 1937 to 1945 [44] as finally determined by you?

A. I don't know, of my present knowledge, I don't know.

Q. Do you know whether or not the reports you turned in formed the basis for the deficiency ultimately assessed by the Commissioner of Internal Revenue?

A. Yes, it was.

Q. What were those records you described as having not been made previously available, which were made available at the time of your examination. What kind of records were they?

A. Records pertaining principally to expenses—yes, with regard principally to expenses.

Q. What was the nature of the records. Were they notes, scribbled pieces of paper, cancelled checks or what kind of records were they?

(Testimony of Edward A. Maier.)

A. I don't actually remember the exact details.

Q. How did you go about computing the income of the taxpayer from the gasoline stations which he owned for the period 1937 to 1941?

A. The prior investigation had been made on the basis of bank deposits, less expenses which had been substantiated and at this time with the help of the accountant we determined or tried to determine the actual gasoline sales and oil sales that had been made and from that determine, on the basis of profit per gallon, the actual profit involved in those sales. After having arrived [45] at the gross profit we then made allowances for expenses which the taxpayer incurred for which he had records either by his cancelled checks or which were reasonable on the basis of the facts that were available.

Mr. Andrews: Nothing further.

#### Cross-Examination

By Mr. Jones:

Q. You have testified that when you came into this particular case that you reduced the tax liability over the prior determination, is that correct?

A. That's right.

Q. And you also testified that your reason for this reduction was because of the existence of additional records. Could you describe these records to the Court?

A. Perhaps there were no additional records in that manner, I am not positive.

(Testimony of Edward A. Maier.)

Q. In other words, you are not positive whether you had any more records than the other examining agent before you?

A. I believe they had found additional contracts, deeds and so forth.

Q. But no additional records for expenditures and things like that?

A. Except insofar as the reasonableness of the situation would point to.

Q. In other words, you applied the rule of normal expenditures [46] of a man engaged in like activity, is that correct?      A. Yes.

Q. Of these expenditures you made quite a substantial allowance, did you not?

A. I don't believe there was a very substantial allowance, I think it was rather nominal.

Q. You don't remember the exact details of the records you examined at the time you went in for your re-examination, is that right?

A. Not the exact detail of that.

Q. You do remember that there were no formal books or records?      A. I do remember that.

Q. In your conferences with the certified public accountant you reviewed substantially the same records in arriving at your figures, is that correct?

A. I don't understand the question.

Q. You have testified heretofore that you examined work sheets prepared by the accountant for the taxpayer, is that correct?

A. That is correct.

Q. And in your redetermination you used essen-

(Testimony of Edward A. Maier.)

tially the same figures that the accountant used and the same records to arrive at those figures, is that correct?

A. I had available, not only the accountant's records but also the records that the Internal Service had at that time from the records of the case. They were used jointly in [47] arriving at the correct income.

Q. There was no great divergence between the accountant's result and the result of the agent that examined these records prior to your determination other than the adjustments that you made, isn't that correct? A. That would be right.

Q. As I understand it, the principal difference was on depreciation schedules and reasonable expenses because you had other records to substantiate these deductions, is that correct?

A. Some of the reasonable deductions but I am not sure on the depreciation whether any adjustments were made or not.

Q. In other words, you don't remember the exact details of your adjustments, is that correct?

A. I haven't given it any considerable review. It is in my report but I don't recall the details.

Mr. Jones: No further questions.

Mr. Andrews: The Government rests, your Honor.

The Court: In view of the fact that we are adjourning for lunch a few minutes early, we will take up fifteen minutes early, that will be at 1:45.

(Testimony of Edward A. Maier.)

Mr. Jones: At that time I would like to make a motion.

The Court: Could you make your motion now, before we adjourn, we have time for that? [48]

Mr. Jones: I would like to make a motion for a directed judgment on evidence as it has been submitted by the Counsel for the Government in this case. I am of the opinion that the Government has not sustained their burden of proof to prove fraud in this particular case. They have shown no evidence of an attempt at concealment, no overt act, no direct act to conceal income, all they have shown is passive conduct on the part of the taxpayer, namely, his failure to file tax returns. There are at least two cases in the Federal Court that require more than a failure to file returns to sustain a charge of fraud——

(Remarks of counsel on motion.)

The Court: I will deny the motion, but I will reconsider the entire matter at the end of the case, and I will go into that just as if I had not ruled on this motion. Court will now adjourn until 2:00 o'clock this afternoon.



February 7, 1956—2:00 P.M.

LEE G. POWELL

called as a witness by the Plaintiff, after being first duly sworn, testifies as follows:

Direct Examination

By Mr. Jones:

Q. Mr. Powell, will you state your residence?

A. 6715 Highland Drive, Vancouver, [49] Washington.

Q. Will you state your relationship to the deceased taxpayer, O. E. Powell, in this case?

A. He was my father.

Q. What is your business, Mr. Powell?

A. I am in the wholesale gasoline and fuel oil business.

Q. How many establishments do you have in the conduct of that business?

A. Oh, we operate approximately thirty-five service stations and sell twenty-four or twenty-five distributors.

Q. How long have you been in business, Mr. Powell?

A. I have been in the oil business since I was out of college, which was in 1928.

Q. How much college training did you have, Mr. Powell?      A. I had two years in college.

Q. Will you state the date of the death of your father, O. E. Powell, the deceased taxpayer in this case?

A. My father passed away in July, 1954.

(Testimony of Lee G. Powell.)

Q. What was his age at the date of his death?

A. He was seventy-three.

Q. Seventy-three years old—where was your father born?      A. He was born in Ohio.

Q. Are you acquainted with the educational background of your father?      A. Yes.

Q. What was that educational background?

A. He had equivalent to a high school [50] education.

Q. How long was your father a resident of the State of Oregon?

A. We moved to Oregon in 1921.

Q. When your father moved to Oregon, what business did he engage in?

A. He went in the service station business when we first came here.

Q. How extensive was his business to begin with?      A. He built one service station.

Q. How large a service station was this?

A. In those days it was a pretty small business; it was on a 100 by 100 lot with three pumps.

Q. Three gasoline pumps on a lot?

A. Yes, sir.

Q. Did he subsequently enlarge his business?

A. Yes, he did. He acquired other locations later.

Q. What would you estimate as the maximum number of locations that he had in the service station business?

A. I think the most he had at any one time was seven service stations.

(Testimony of Lee G. Powell.)

Q. Did he do anything, did he engage in any other business activities aside from the conduct of these service stations?

A. Yes; he dabbled in real estate quite extensively besides the oil business.

Q. Could you tell the Court about what year he started to [51] engage in the real estate business?

A. Actually he had a real estate broker's license, and I don't recall exactly the year but I would say somewhere around '41 or '42.

Q. In the conduct of this business, did your father ever engage the service of a regular bookkeeper?

A. I don't recall him ever having a regular bookkeeper, no.

Q. Do you know who kept his books and records generally?

A. I think he kept them himself.

Q. Kept them himself?

A. Yes, I think so.

Q. Now, did your father have any church affiliations?

A. Yes, he did; he belonged to a church.

Q. Did he attend church regularly?

A. Almost every Sunday, I would say.

Q. Almost every Sunday when he was able?

A. Yes.

Q. Did he participate actively on committees in the church, any particular committees?

A. Yes; when they built a new church, I am positive that he was on the finance committee.

Q. Did he actively participate in any other community affairs?

(Testimony of Lee G. Powell.)

Mr. Andrews: Your Honor, at this point I would like to object on the ground that this is very obviously immaterial to the issues in this case.

The Court: I think it is, but this is a [52] matter before the Court and I will let him go ahead.

Q. Was your father active in politics?

A. To a certain extent, I would say yes.

Q. Did he actively engage in political activity or were his more of strong political beliefs?

Mr. Andrews: Now, I object to that, your Honor, as being incompetent, irrelevant and immaterial.

The Court: Yes, I think so, but I will let him answer.

A. He participated in certain campaigns where he was fairly well sold on the candidate. I know of a few contributions that he made and a small amount of campaigning but he had never run for any office or been what you would call very active in politics.

Q. Did he have strong political beliefs?

A. Yes, he did.

Q. How close were you to your father?

A. Well, we were very close, we were in the same business. We have always been a family—not a large family, but two sisters and a brother, we had lots of family affairs and dinners. We were very close.

Q. You visited his home? A. Yes.

Q. Often? A. Yes.

Q. And he yours? A. Yes. [53]

Q. During the course of these visits from the

(Testimony of Lee G. Powell.)

year 1937 to the year 1945, did you often engage in a discussion of business activities?

A. Yes, we did.

Q. During those years in question, was the subject of taxes ever discussed?      A. Yes.

Q. What statements did he make to you, during those years, concerning income taxes?

A. I knew that he wasn't paying his income tax and I asked him about it and told him that he should be paying, that it was the thing for him to do, and he said he knew it but that he didn't pay because he didn't believe in the way that the Government was wasting the money.

Q. Did your father ever make any direct statement concerning his conviction on taxes?

A. Yes.

Q. What were those statements?

A. That he believed in taxation but he didn't believe that the Government should waste the money.

Q. Did your father make these statements freely and voluntarily to all other members of your family?      A. Yes.

Q. Are you aware of any outsiders that he might have made these statements to?

A. I don't recall any outsiders. [54]

The Court: I guess this was before he could have read any news dispatches about a Governor's actions.

Mr. Andrews: Yes, your Honor.

Q. Then his statement for failure to file these returns was mainly based upon political convictions,

(Testimony of Lee G. Powell.)

is that correct?      A. Yes, that's correct.

Q. What was your advice to your father concerning his failure to file tax returns and pay the taxes?

A. My advice was for him to pay it. I knew that he should pay it.

Q. What was his reaction when you urged him to do this?

A. His reaction was that he would do that when and if he felt it was time to do it.

Q. Over what period of time did these discussions take place and with what frequency?

A. I think about every time I had to pay income tax, over the period, I would say, from '37 to '45.

Q. Did you ever have any business dealings with your father?      A. Yes.

Q. Could you advise the Court of the extent of these business dealings with your father?

A. He decided to get out of his service station business and I leased five service stations that he owned. I believe the first year was 1941. [55]

Q. 1941?

A. I am still leasing them today, from my mother.

Q. You paid regular rentals to your father?

A. That's correct, yes, sir.

Q. During that time, depending upon the conditions?      A. That's correct.

Q. And you presently are leasing these stations from your mother, is that correct?

A. That's correct.

(Testimony of Lee G. Powell.)

Q. Now, do you recall when you made rental payments to your father, how you made those payments?      A. Yes, once a month.

Q. Were they made by cash or check?

Mr. Andrews: I object to that, your Honor. I believe that the cancelled checks would be the best evidence if it was by check.

The Court: He may answer whether they were made by cash or check.

A. They were made by check.

Q. Now, in your business dealings with your father, was there any attempt or any suggestion by him to make these payments by cash?

A. Never was there any request like that made.

Q. Was there ever any attempt by your father to get you to conceal the source of these payments?

A. No, sir. [56]

Q. Was your father a man of strong religious beliefs?      A. Yes, he was.

Q. Was your father a man of strong political beliefs?      A. Yes.

Q. Was your father a man whom you would consider to be a strong-willed man with the ability to make up his own mind?

A. He certainly was.

Mr. Jones: No further questions.

(Testimony of Lee G. Powell.)

### Cross-Examination

By Mr. Andrews:

Q. I believe you testified that your father kept his own books and records?

A. To the best of my knowledge that's true.

Q. Do you know of a man named Willoughby?

A. I believe I have met a man by that name?

Q. Where did you meet him?

A. At my father's home.

Q. Do you know whether or not he ever worked for your father?

A. He may have made out some tax returns. I don't know that he did any specific bookkeeping. He might have made a summation of the year's business. I don't know, but I don't believe that he was ever hired as a regular bookkeeper. I met him on one or two occasions.

Q. You say that you paid your father by checks?

A. Yes, sir. [57]

Q. Do you have those checks?           A. Yes.

Q. In the courtroom with you?

A. No, I don't.

Q. What happened to them?

A. I think I could produce them clear back as far as '41.

Q. Is it your testimony that you don't have the checks with you in the courtroom?

A. I don't have them with me. I would have to have a truck to bring them in here, I am sure.



(Testimony of Lee G. Powell.)

Q. Would you need a truck to cover just the checks you made to your father for the lease of gas stations for the period 1942 to 1945?

A. I retract that. I wouldn't need a truck, but I would need some time to produce the checks because that goes back a long ways and it would be a big volume of checks.

Q. How old is your mother at this time?

A. I believe my mother is seventy.

Q. And how many sons does she have?

A. Two.

Q. Is it a fair statement to say that if there is any recovery in this case the amount of the recovery would ultimately come to you?

A. No, that isn't true.

Q. Why isn't that true?

A. I have two sisters that are more in need of the money than my brother and I.

Q. Then there are four of you?

A. That is correct. [58]

Mr. Andrews: No further questions.

### Redirect Examination

By Mr. Jones:

Q. Have your books and records ever been examined by any Internal Revenue Agent?

A. Yes, they have.

Q. What Internal Revenue Agent examined your books and records?

A. I don't remember both of their names but I

(Testimony of Lee G. Powell.)

believe that Mr. Forsberg was one. I believe the other passed away.

Q. Is that Mr. Forsberg the one that is present in Court?      A. I think so.

Q. Did Mr. Forsberg ever question you about payments made to your father by you?

A. Yes.

Q. Did Mr. Forsberg ever make a determination of a deficiency in your income tax for any years in question, 1937 to 1945, inclusive?

A. They went through my books and they asked me lots of questions. I don't recall the questions, but they asked me lots of questions.

Q. Mr. Powell, what would you estimate the present fair market value of all of your assets?

A. Of mine?

Q. Yes, just a rough estimate.

A. Four hundred thousand dollars. [59]

Q. Then in relationship to your total net worth any possible bequest that you might possibly get from your mother would not amount to very much to you?      A. That is true.

Q. From a financial viewpoint, other than personal feeling?      A. That's true.

Q. The amount involved in this case would not be in excess of \$16,000.00, or \$4,000.00 to you, assuming that your mother left one-fourth of her estate to you, the \$4,000.00 additional wouldn't mean too much to you in relation to your total net worth?      A. That's true.

Mr. Jones: That's all.

Mr. Andrews: No further questions, your Honor.

BERNARD MILKES

called as a witness by the Plaintiff, after being first duly sworn, testifies as follows:

Direct Examination

By Mr. Jones:

Q. What is your name?

A. Bernard Milkes.

Q. What is your occupation?

A. I am a certified public accountant.

Q. Your residence, Mr. Milkes?

A. 7622 Southeast 36th, Portland.

Q. Would you state to the Court your educational background? [60]

A. Well, I am certified as far as my accounting is concerned, and I attended the University of Minnesota.

Q. You are a graduate of the University of Minnesota?

A. I didn't quite graduate, but I did pass the CPA examination.

Q. And are certified as a public accountant?

A. Yes, have been for ten years, and teach accounting.

Q. You teach accounting?

A. Yes, I teach accounting at Portland State if that will help the record any.

Q. How long have you been engaged in the accounting business?

A. Probably twenty years.

Q. Twenty years, has that been as a principal all of that time?

(Testimony of Bernard Milkes.)

A. No. I was in private accounting for about eight years and then I practiced with a national accounting firm for about three years and the balance of the time I have been in my own business.

Q. What National Accounting Firm were you with?

A. Peet-Marwisk-Mitchel and Company.

Q. Were you acquainted with Mr. Ora E. Powell, the deceased Plaintiff in this case?

A. Yes.

Q. In what connection were you acquainted with Mr. Powell?

A. In connection with these tax affairs that are under discussion.

Q. What was your first contact with Mr. Ora E. Powell? [61]

A. Mr. Powell called me in and stated that he wanted me to reconstruct his records, that he had had this tax situation and that I was to work on the reconstruction of the records with the attorney in the case.

Q. What date was your first contact with Mr. Powell? Can you tell the Court the year?

A. I can't remember the date at all. I would say that it was somewhere in the forties.

Q. Late 1940's?

A. I would think so; the case covers '41 to '48, doesn't it?

Q. 1937 to 1945.

A. '45; well, then, I got in about '47, I would say.

(Testimony of Bernard Milkes.)

Q. Were you ever contacted by the Internal Revenue service concerning this case?

A. Yes, sir. I worked with two of the boys, at times, on this case, from the Internal Revenue.

Q. What agents from the Internal Revenue Service did you deal with on this case?

A. Mr. Forsberg and the man that testified this morning.

Q. Mr. Maiers?                   A. Mr. Maiers, yes.

Q. For the years 1937 to 1945, inclusive, did you compute the net taxable income of Mr. O. E. Powell?

A. Yes, to the best of our ability, from the records available.

Q. What method did you use to reconstruct the taxable net income for the taxable years 1937 to 1945? [62]

A. I went out to Mr. Powell's home and he furnished me with all of the papers that he had available which included all of the cancelled checks and bank statements, or copies of the bank statements that he had obtained from the bank, and also all various property tax—not property tax but property papers, that is, deeds and things of that nature and we tried to reconstruct records from that information.

Q. Did you have the opportunity to compare your results with the results reached by the Internal Revenue Service?                   A. Yes, I did.

Q. How did your results compare with the results reached by the Internal Revenue Service?

A. Well, after we made some minor adjust-

(Testimony of Bernard Milkes.)

ments on the property transactions—while I had a couple of duplications and had missed a couple, we compared, and after that was over I would say that substantially the income figure was about the same.

Q. Then the adjustments that you made—you might have made a duplication of two pieces of property?

A. That's right.

Q. But your results were substantially the same as the Internal Revenue Service—your independent results were the same as those reached by the Internal Revenue Service?

A. Yes, that's right.

Q. Did you have a lot of trouble reaching these results? [63]

A. It took a lot of time as cases of that kind do when you don't have formal records. However, I wouldn't say that we had trouble.

Q. Were your results gained from the same records used by the Internal Revenue Service?

A. I don't know what records they used but I believe that my records on the property transactions were taken entirely from the deeds and contracts and things of that kind, whereas I understood that the Internal Revenue got some of their information from the actual records in the courthouse.

Q. During this period in question—after your first contact with Mr. Powell, how well acquainted did you become with Mr. Powell?

A. I would say quite well acquainted because I practically lived out at his place while we were making up the record.

(Testimony of Bernard Milkes.)

Q. Would you say that you knew him well enough to know his habits and peculiarities?

A. I think so, yes.

Q. Was Mr. Powell a man of strong beliefs?

A. Yes, I would say he was.

Q. In your opinion, was Mr. Powell a man of strong political convictions?

A. Yes, I would say he was.

Q. Would you say that Mr. Powell was a man of strong religious convictions? [64]

A. He definitely was.

Q. In your search of Mr. Powell's affairs, did you find any evidence of his having attempted to destroy any records? A. Absolutely not.

Q. Did you find any evidence of his having attempted to alter any records?

A. No, none at all.

Q. Did you have occasion to discuss with Mr. Powell his reason for not filing income tax returns for the taxable years 1937 to 1945?

A. Many times.

Q. Did Mr. Powell give any reason for his failure to file returns?

A. His statement was that he couldn't see any use in contributing to the Government when they were wasting the money.

Q. Did he ever voice any of his convictions about taxes to you?

A. Well, his conviction on taxes were that he knew that the Government had to have money, any governing body had to have money in order to exist,

(Testimony of Bernard Milkes.)

but that he couldn't see any point in payment so much more than they had to waste it. There was no question but what he believed in tax, but a reasonable tax.

Q. When Mr. Powell furnished these records to you for examination and recomputation, were these same records available to the Internal Revenue Service? [65]

A. To the best of my knowledge the records were the only records that were available and he had made no attempt whatever to hold back any records at all. I went out to his house and he brought out everything he had and it was up to me to dig through them and pick out what I wanted.

Q. Did you ever take these records to your office?

A. I had parts of them at my office, yes.

Q. When Mr. Maiers was in your office comparing these results, were these records available to him? Did you make these records available to him?

A. I don't think that question ever came up. We compared final results from my work papers to his work papers, but I don't think we ever actually went through any of the original records. To my knowledge there were never any records held back. I never had that experience.

Mr. Jones: Your witness.



(Testimony of Bernard Milkes.)

Cross-Examination

By Mr. Andrews:

Q. I believe you testified that you came to approximately the same result that Internal Revenue Agent Maiers, that is, the same figure that he came to in computing income tax deficiencies?

A. No, oh, no, in income; I changed that statement. I think the record will show that my statement was that we arrived at substantially the same figures in income. [66]

Q. Is that gross income?

A. Taxable income.

Q. What were the differences between you and Mr. Maiers?

A. There were no differences so far as I know, so far as the taxable income was concerned, that's what I said that we arrived at approximately the same figures using two different methods.

Q. Two different methods based on the same material, wasn't it?

A. Not necessarily, like I said in the record here. I think he got some of his information from the property records, but I don't know.

Q. And you got your information from what source?

A. From the contracts and various papers that you go through when you sell or buy property.

Q. Where in these contracts does it say anything

(Testimony of Bernard Milkes.)

about the amount of profit that brokers realize on a sale?

A. Well, we had amounts that he paid for the property, and the contracts show amounts that he sold the property for. Many of the properties he actually bought on contract and then also sold on contract and the information would be there for that.

Q. Some of these contracts were matters of public records and others were not?

A. That I don't know, I never checked the public records.

Q. You said that the Internal Revenue Agents checked them? [67]

A. I said that I thought they did.

Q. So if they did they were really checking the same material that you had?

A. Don't put words in my mouth; I don't know.

Q. I am asking you.

A. I don't know. All I said was that I thought they did.

Q. Then you don't know what they did?

A. No, I don't know what the Internal Revenue Agents did. I just know that we arrived at substantially the same figure.

Q. How did you arrive at the amount of income realized by Mr. Powell from the operation of the gas stations during the period from 1937 to 1941?

A. I took the checks that he had issued for the payment of the gasoline and then I called, I believe, one of the major gas companies and they furnished us with the prices that he had paid at that time for gas-

(Testimony of Bernard Milkes.)

oline and we divided one into the other to determine the number of gallons, and then we arrived, also by contact with the National Firms, the approximate selling price so that we knew how many cents per gallon were made in profit and thus arrived at our profit, and I believe that I discussed this matter with Mr. Maiers and we both agreed that it seemed reasonably fair.

Q. Then it was a complicated method?

A. I wouldn't say it was complicated. [68]

Q. Would you say it was simple?

A. Yes; it wasn't very hard.

Q. All you had to do was to call up some Gas Companies and project some figures and there you had it?

A. No; we had genuine cancelled checks from the bank that indicated actual purchases of gasoline, and in contacting the Gas Companies we knew the exact date that he had bought it and they keep the kind of records that would tell us the cost price and the selling price of gasoline at that time.

Q. At any rate, you were able to determine the income from the gas stations because the Gas Companies and the Banks kept good records?

A. I would say so, but quite often, in an accounting procedure where you are rebuilding past records, you make use of outside sources for information.

Q. You were hired by Mr. Powell to make a re-computation of his net income for the years 1937 to 1945?

(Testimony of Bernard Milkes.)

A. I wouldn't say a recomputation; I would say a computation.

Q. You took his money? A. Pardon.

Q. You took his money for that job?

A. I got paid for doing the work, yes. I get paid for all the accounting work I do, or most of it.

Q. You say that you found no attempt on his part to conceal any record or any alterations of any kind—were you looking for any? [69] A. No.

Mr. Andrews: That is all.

### Redirect Examination

By Mr. Jones:

Q. Mr. Milkes, in your work in accounting you are primarily looking for—one of your primary purposes is looking for discrepancies in records, is that correct?

A. Yes, I would say that is correct, not looking for fraud or anything like that but looking for errors in recording the information for accounting purposes—for tax purposes and I might say, incidentally, for fraud also.

Q. It is your nature to observe in going through data for accounting, any irregularities such as alterations? A. Yes.

Q. And it is your practice to observe any destruction of records or subsidiary records?

A. Well, sure, if there is any evidence of it.

Q. Then, chances are, in the course of your examination, if there had been any alterations or destruc-

(Testimony of Bernard Milkes.)

tion of these records it would have come to your attention?      A. Yes, sir.

Q. Were the subsidiary records that were made available to you for the taxable years 1937 to 1945 adequate to fairly reconstruct the income and expenditures of Mr. Ora E. Powell?

A. Substantially so, yes.

Mr. Jones: Your witness. [70]

Mr. Andrews: No further questions.

Mr. Jones: I would like to call Mr. Lee Powell to the stand.

LEE G. POWELL

recalled as a witness for the Plaintiff, having heretofore been duly sworn, testifies as follows:

Direct Examination

By Mr. Jones:

Q. Mr. Powell, you have heretofore testified that your Father had a real estate Broker's license?

A. That's true.

Q. In his real estate transactions, to the best of your knowledge, did your Father ever employ a Broker or pay a Broker for handling real estate transactions?

A. It is hard for me to answer that because he had lots of transactions that I didn't follow too closely. There is a possibility that he bought through another broker or sold through one. I know that it is common practice for brokers to co-operate and split commissions and so forth.

(Testimony of Lee G. Powell.)

Q. But he did have a broker's license?

A. Yes, he did.

Q. During a portion of these years, and did handle his own real estate transactions? A. Yes.

Q. Are you aware of a substantial number of transactions that he handled himself and paid no real estate Broker's [71] commission?

A. Yes; I know of quite a few.

Mr. Jones: No further questions.

Mr. Andrews: Nothing further.

Mr. Jones: Your Honor, we rest our case.

The Court: Does the Government have anything further?

Mr. Andrews: Nothing further except that I believe that Mr. Jahnke would like an amendment to the pretrial order. I understand that under local practice the Pretrial order is a part of the record.

The Court: Yes, it is.

Mr. Jahnke: We would like to orally amend the pretrial order so that the plaintiff may make the additional contention that on the amount of any recovery which it may be awarded in this case, the recovery will bear interest in the statutory rate, and in the statutory amount, and we would further stipulate that if there was any recovery in this case that the amount of the recovery should be subject to recomputation by the Internal Revenue Service, following which a stipulation of judgement would be filed with the Court.

(Further statement of Court and counsel as to procuring transcript and filing briefs.)

Mr. Jones: For the record I would like to reassert the motion I made at the close of the Governments case. [72]

The Court: Yes, it is understood that it is re-asserted and the Court will, as suggested before, take the whole matter under consideration in the final determination of the case. [73]

State of Idaho,  
County of Ada—ss.

I, G. C. Vaughan, hereby certify that I am an official Court Reporter for the United States District Court, and

I further certify that I am the Reporter who took the testimony and proceedings given and had in the above-entitled matter, in shorthand, and thereafter transcribed the same into longhand (typing), and

I further certify that the foregoing transcript, consisting of pages numbered to 73, is a true and correct transcript of said testimony and proceedings.

In Witness Whereof, I have hereunto set my hand this 17th day of April, 1956.

/s/ G. C. VAUGHAN,  
Reporter.

[Endorsed]: Filed February 15, 1957.

[Title of District Court and Cause.]

### CERTIFICATE OF CLERK

United States of America,

District of Oregon—ss.

I, R. DeMott, Clerk of the United States District Court for the District of Oregon, do hereby certify that the foregoing documents consisting of Complaint; Answer; Pretrial order; Opinion; Findings of fact and conclusions of law; Judgement; Notice of appeal; Bond for costs on appeal; Statement of points on appeal; Designation of contents of record on appeal and Transcript of docket entries, constitute the record on appeal from a judgment of said court in a cause therein numbered Civil 7837 in which Grace M. Powell, Executrix of the Estate of O. E. Powell, Deceased, is the plaintiff and appellant and Ralph C. Granquist, District Director of Internal Revenue, is the defendant and appellee; that the said record has been prepared by me in accordance with the designation of contents of record on appeal filed by the appellant, and in accordance with the rules of this court.

I further certify that the reporter's transcript will be forwarded as soon as it is filed in this office and the exhibits will be forwarded at a later date.

I further certify that the cost of filing the notice of appeal, \$5.00, has been paid by the appellant.





In the United States Court of Appeals  
for the Ninth Circuit

No. 15447

GRACE M. POWELL, Executrix of the Estate of  
O. E. Powell, Deceased,

Appellant,

vs.

RALPH C. GRANQUIST, District Director of  
Internal Revenue,

Appellee.

### STATEMENT OF POINTS ON APPEAL

In accordance with Subsection 6 of Rule 17 of the rules of this court, the following is a statement of the points upon which the appellant intends to rely:

#### I.

The Federal District Court of the United States for the District of Oregon, erred in concluding and holding that the deficiencies in income taxes assessed by the Commissioner of Internal Revenue against Ora E. Powell and collected by the appellee herein for the years 1937 through 1945, inclusive, were due to fraud with intent to evade tax within the meaning of Section 293(b), Internal Revenue Code of 1939, and that the collection of \$12,880.39 from Ora E. Powell and/or the appellant herein by the appellee as the amount of the penalty as imposed by Section 293(b), Internal Revenue Code of 1939,

for the years 1937 through 1945, inclusive, were proper, by reason of the fact that the defendant-respondent failed to sustain his burden of proof as required by law.

Dated this 17th day of April, 1957.

/s/ **FREDERICK A. JAHNKE,**  
Attorney at Law.

Service of copy acknowledged.

[Endorsed]: Filed April 22, 1957.

THE UNIVERSITY OF CHICAGO

PHYSICS DEPARTMENT  
5712 S. DICKINSON DRIVE  
CHICAGO, ILL. 60637

Dear Sir:

I am pleased to inform you that your application for admission to the Ph.D. program in Physics has been accepted.

Your admission is contingent upon your successful completion of the required pre-admission examinations and the receipt of a letter of recommendation from your current institution.

Please contact the Department Office at the above address for further details regarding the admission process and the start date of the program.

United States  
**COURT OF APPEALS**

for the Ninth Circuit

---

GRACE M. POWELL, Executrix of the Estate of O. E.  
POWELL, Deceased,

*Appellant,*

vs.

RALPH C. GRANQUIST, District Director of Internal  
Revenue,

*Appellee.*

---

*On Appeal from the Judgment of the United States  
District Court for the District of Oregon*

---

**BRIEF FOR THE APPELLANT**

---

HUMPHREYS & JONES,  
ARTHUR D. JONES,  
904 Yeon Building,  
Portland 4, Oregon,

FREDERICK A. JAHNKE,  
815 Executive Building,  
Portland 4, Oregon,

*Attorneys for Appellant.*

FILED

JUL - 9 1957

PAUL P O'BRIEN, CLERK, OREGON



## INDEX

	Page
Opinion below .....	1
Jurisdiction .....	1
Questions presented .....	3
Statement .....	3
Statement of points to be urged.....	6
Summary of argument .....	7
Argument .....	7
The failure to file income tax returns does not justify the imposition of the fraud penalty.....	7
The imposition of the fraud penalty requires wil- ful commission .....	13
Conclusion .....	18

## CITATIONS

	Page
Cave v. United States, 159 Fed. (2d) 464.....	12, 13
First Trust and Savings Bank v. United States, 206 Fed. (2d) 97.....	11, 13, 15, 16, 17
Jemison v. Commissioner, 45 Fed. (2d) 4.....	15, 17
Mitchell v. Commissioner, 118 Fed. (2d) 308.....	15
Ohlinger v. United States, 219 Fed. (2d) 310.....	15, 17
Owens v. United States, 98 Fed. Supp. 621, affd. 197 Fed. (2d) 450.....	15
Rogers v. Commissioner, 111 Fed. (2d) 897.....	15, 17
Spies v. United States, 317 U.S. 492.....	9, 10, 12, 13, 18
United States v. Murdock, 290 U.S. 389.....	9
Wisley v. Commissioner, 185 Fed. (2d) 263.....	15

## STATUTES

### Internal Revenue Code:

Sec. 145(a) .....	8, 9, 10, 11, 15, 17
Sec. 145(b) .....	8, 9, 10, 11
Sec. 291 .....	12
Sec. 293(b) .....	3, 6, 7, 10, 11, 18
Sec. 3772 .....	2
28 U.S.C. 1291.....	2
28 U.S.C. 1340.....	2



**United States**  
**COURT OF APPEALS**  
**for the Ninth Circuit**

---

GRACE M. POWELL, Executrix of the Estate of O. E.  
POWELL, Deceased,  
*Appellant,*  
vs.

RALPH C. GRANQUIST, District Director of Internal  
Revenue,  
*Appellee.*

---

*On Appeal from the Judgment of the United States  
District Court for the District of Oregon*

---

**BRIEF FOR THE APPELLANT**

---

**OPINION BELOW**

The District Court rendered its opinion, which is reported 145 Fed. Supp. 308 (R. 77-84). Its findings of fact and conclusions of law (R. 84-88) are unreported.

**JURISDICTION**

Grace M. Powell is the duly appointed and qualified executrix of the Estate of O. E. Powell who died on July 16, 1954 (R. 3).

Deficiencies of income tax for 1937, 1938, 1939, 1940, 1941, 1942, 1943, 1944, 1945, were assessed by the Commissioner of Internal Revenue against O. E. Powell (R. 4, 6, 9, 11, 14, 16, 19, 22, 25). All of the amounts in dispute in this proceeding have been paid by Grace M. Powell, Executrix of the Estate of O. E. Powell herein, and/or O. E. POWELL, and were so paid prior to filing the claims for refund (R. 5, 8, 10, 12-13, 15, 18, 21, 24, 27). On or about July 15, 1954, O. E. Powell filed a timely claim for refund for each of the taxable years in controversy (R. 5, 8, 10, 12-13, 15, 18, 21, 24, 27). The District Director of Internal Revenue, appellee herein, mailed to the taxpayer on or about October 7, 1954, his notice of disallowance in full of all of the said claims for refund by registered mail (R. 5, 8, 10-11, 13, 15-16, 18, 21, 24, 27), and thereafter this suit was commenced in the United States District Court for the District of Oregon for the recovery of all of the amounts in controversy, within the time provided in Section 3772 of the Internal Revenue Code of 1939 (R. 70). Jurisdiction was conferred on the District Court by 28, U.S.C. Section 1340 (R. 3, 6, 9, 11, 14, 16, 19, 22, 25). This case was tried before the United States District Court for the District of Oregon and judgment was entered in part for Appellees on December 26, 1956 (R. 89). Within 60 days thereafter, January 9, 1957, notice of appeal was filed from so much of the decision that was rendered against Appellant (R. 90). Jurisdiction is conferred on this Court by 28 U.S.C. Section 1291.

## QUESTIONS PRESENTED

Whether the United States District Court for the District of Oregon erred in concluding and holding that deficiencies in income taxes assessed by the Commissioner of Internal Revenue against O. E. POWELL and collected by the Appellee herein for the years 1937 through 1945, inclusive, were due to fraud with intent to evade the tax within the meaning of Section 293 (b), Internal Revenue Code of 1939, and that the collection of \$12,880.39 from ORA E. POWELL and/or the Appellant herein by the Appellee of the amount of the penalty imposed by Section 293 (b), Internal Revenue Code of 1939, for the years 1937 through 1945, inclusive were proper by reason of the fact that the Appellee failed to sustain his burden of proving fraud by clear and convincing evidence.

## STATEMENT

The pertinent facts as found by the District Court are as follows (R. 77-80):

The taxpayer received taxable income for the years 1937 through 1945, inclusive, but filed no federal income tax returns for those years. Failure of the taxpayer to file income tax returns came to the attention of the Internal Revenue Service in January, 1946; whereupon an investigation was begun to determine the taxpayer's taxable income for the years involved. During the years 1937 to 1945, taxpayer owned and operated a number of gasoline service stations, later leasing them to the two

sons, Lee G. Powell and Vincent O. Powell, receiving from them rental incomes. Also taxpayer, at various times during that period, had 19 different properties that he rented, and also during that time, he made in excess of 30 real estate sales, farms and residences, and also had interest income on contracts and commissions from realty sales. In order to determine taxpayer's income, it was necessary that the Internal Revenue agent search public records of four counties, determine from the sons how much they leased the stations for, and contact real estate agents and other parties to the various transactions. This was necessary because taxpayer had indicated that he kept no records (R. 77-78).

Deficiencies in income tax were ultimately determined and assessed for 1937 through 1945, together with fraud penalties and penalties for failure to file declaration of estimated tax and for substantial underestimated tax. The amounts assessed as tax are not in controversy here, but only the correctness of the assessment of the 50% fraud penalty. At the time of trial, counsel for the taxpayer conceded the 25 per cent penalty for willful failure to file income tax returns (R. 78).

This case does not involve income tax returns fraudulently filed, but rather is concerned with the situation where there was no tax return filed at all (R. 79).

The evidence disclosed that Mr. Powell, during this period, with his failure to file, made it known that he was not in sympathy with the administration and did not like the way the government was run and did not believe in paying taxes (R. 80).

The taxpayer's son testified that he told his father that he should be paying income taxes, that it was the thing for him to do, and he, the father, said he knew it, but didn't pay because he didn't believe in the way the government was raising money; he said he believed in taxation, but didn't believe that the government should waste the money. His failure to file returns was based primarily upon political convictions (R. 80-81).

There is no evidence in the record of alteration or concealment of bank statements, cancelled checks or real estate contracts by the taxpayer. Mr. Powell said he did not have records, and there is no evidence of these having been destroyed or falsely made. The records which Powell kept were adequate for him to carry on his business profitably, yet Powell never volunteered any records, information or contracts. His only and various transactions were discovered by Internal Revenue Agents on specific requests made for all records and documents pertinent thereto, they were made by the taxpayer (R. 81).

From the evidence presented, and the record herein, it was found that the following factors were present to some degree in this case: Gross understatement of income, failure to keep proper books and records, failure to cooperate with investigating agents, and the giving of evasive answer (R. 79).

## STATEMENT OF POINTS TO BE URGED

1. There is no evidence to support the Findings of Facts No. 8 (R. 86) and the District Court was in error in making such a finding, which asserts:

“Ora E. Powell did not keep books and records adequate to show his income during the years 1937 through 1945.”

2. There is no evidence to support the Finding of Fact No. 10 (R. 87) and the District Court erred in making such a finding which asserts:

“Ora E. Powell gave evasive answers to the Internal Revenue Agents attempting to ascertain his taxable income for the years 1937 through 1945, and did not cooperate with the agents in their investigation.”

3. There is no evidence to support the Finding of Fact No. 11 (R. 87) and the District Court erred in making such a finding which asserts:

“The failure of Ora E. Powell to file any federal income tax returns for the years 1937-1945 was knowingly, willful and intentional, and was due to fraud with intent to evade tax.”

4. There is no evidence to support the Conclusion of Law No. 4 (R. 87-88) and the District Court erred in making such a conclusion which held:

“Deficiencies in income tax assessed by the Commissioner of Internal Revenue against Ora E. Powell for the years 1937-1945 were due to fraud with intent to evade tax within the meaning of Section 293 (b) Internal Revenue Code, and the 50 per cent defraud penalty assessed against Ora E. Powell by the Commissioner of Internal Revenue for the years 1937-1945, were proper.”

## SUMMARY OF ARGUMENT

The District Court erred in finding that the 50 per cent fraud penalty assessed pursuant to Section 293 (b) Internal Revenue Code of 1939, for failure of O. E. Powell to file income tax returns was proper. The Appellee failed to sustain his burden of proving by clear and convincing evidence that the deficiency in income tax for each of the taxable years involved herein was due to fraud with intent to evade tax and accordingly the decision rendered below should be reversed.

The Commissioner must sustain his burden of proof, by clear and convincing evidence to sustain the assessment of the fraud penalty pursuant to Section 293 (b) Internal Revenue Code of 1939. The record in this case is wholly bare of the usual indicia of fraud. The factors which usually are considered to be badges of fraud are: (1) Keeping a double set of books; (2) making false entries or alterations; (3) false invoices or documents; (4) destruction of books or records; (5) concealment of assets or covering up sources of income; (6) handling of own affairs to avoid the making of records usual in transactions of this kind; (7) any conduct, the likely effect of which would be to mislead or to conceal.

## ARGUMENT

### **The Failure to File Income Tax Returns Does Not Justify the Imposition of the Fraud Penalty**

The Court below in concluding (R. 82) that the imposition of the 50% fraud as imposed by Section 293

(b), Internal Revenue Code of 1939, in addition to the 25% penalty for failure to file income tax returns as imposed by Section 291 (a), Internal Revenue Code of 1939, was proper said:

“Here Mr. Powell’s omission was not accidental. It was purposeful, wilful and deliberate omission to file and pay income taxes. Should this court hold that there was no fraud with intent to evade taxes in this case, it would open the door to all who desire to evade taxes to escape the fraud penalty by wilfully and deliberately failing to file. . . .”

The above observations are incompatible with those sections of the Internal Revenue Code of 1939 which set up the statutory scheme for the imposition of civil penalties for the various omissions of taxpayers. Bear in mind that the taxpayer *paid the penalty for failure to file his income tax return and has admitted that this penalty was proper*. The teachings of the Supreme Court of the United States militates against the construction placed on the statutes by the court below. The Court of Appeals for the 8th Circuit, the only other court to pass directly on the issue posed here held that only the lesser penalty was proper and held that the 50% fraud penalty was improper. These decisions are discussed infra.

Compare the structure of the criminal sections of the Internal Revenue Code with the structure of the civil section. Section 145 (a) makes it a misdemeanor to wilfully fail to file a return; while section 145 (b) makes it a felony to “. . . wilfully attempt in any manner to evade or defeat any tax . . .” These sections have been construed by the United States Supreme Court to



have definite meaning in our tax system. The mere willful failure to file a return, no matter how willful, is punishable only as a misdemeanor. *Spies v. U. S.*, 317 U.S. 492. The court in making its distinction between Section 145 (a) and 145 (b) said:

“The difference between willful failure to pay a tax when due, which is made a misdemeanor, and willful attempt to defeat and evade one, which is made a felony, is not easy to detect or define. *Both must be willful, and willful, as we have said, is a word of many meanings*, its construction often being influenced by its context. *United States v. Murdock*, 290 U.S. 389. It may well mean something more as applied to nonpayment of a tax than when applied to failure to make a return. Mere voluntary and purposeful, as distinguished from accidental, omission to make a timely return might meet the test of willfulness. But in view of our traditional aversion to imprisonment for debt, we would not without the clearest manifestation of Congressional intent assume that mere knowing and intentional default in payment of a tax where there had been no willful failure to disclose the liability is intended to constitute a criminal offense of any degree. We would expect willfulness in such a case to include some element of evil motive and want of justification in view of all the financial circumstances of the taxpayer.

“Had § 145 (a) not included willful failure to pay a tax (it would have defined as misdemeanors generally *a failure to observe statutory duties to make timely returns*, keep records, or supply information—duties to facilitate administration of the Act even if, because of insufficient net income there were no duty to pay a tax. It would then be a permissible and perhaps an appropriate construction of § 145 (b) that it made felonies of the same willful omissions when there was the added element of duty to pay a tax. The definition of such nonpay-

ment as a misdemeanor we think argues strongly against such an interpretation." (Emphasis added.)

In comparing Sections 145 (a) and 293 (b), note that the language is similar. The offense is described in Section 145 (b) as ". . . any person who willfully attempts in any manner to evade or defeat any tax . . ." and in Section 293 (b) "If any part of the deficiency is due to fraud with intent to evade tax . . ." The latter civil section uses stronger language than the criminal section. The civil section speaks of *fraud*. In the *Spies* case, *supra*, the court in commenting on the terminology of Sections 145 (a) and 145 (b) said:

"The difference between the two offenses, it seems to us, is found in the affirmative action implied from the term "attempt," as used in the felony subsection. It is not necessary to involve this subject with the complexities of the common law "attempt." The attempt made criminal by this statute does not consist of conduct that would culminate in a more serious crime but for some impossibility of completion or interruption or frustration. This is an independent crime, complete in its most serious form when the attempt is complete and nothing is added to its criminality by success or consummation, as would be the case, say, of attempted murder. Although the attempt succeed in evading tax, there is no criminal offense of that kind, and the prosecution can be only for the attempt. *We think that in employing the terminology of attempt to embrace the gravest of offenses against the revenues Congress intended some willful commission in addition to the willful omissions that make up the list of misdemeanors.* Willful but passive neglect of the statutory duty may constitute the lesser offense, but to combine with it a willful and *positive attempt to evade tax in any manner or to defeat it by any means lift the offense to the degree of felony.*" (Emphasis added.)

The court required "willful commissions" distinguished from "willful omissions." By way of illustrating the court cited conduct which would qualify as "willful commission:"

"Congress did not define or limit the methods by which a willful attempt to defeat and evade might be accomplished and perhaps did not define lest its effort to do so result in some unexpected limitation. Nor would we by definition constrict the scope of the Congressional provision that may be accomplished "in any manner." By way of *illustration, and not by way of limitation, we would think affirmative willful attempt may be inferred from conduct such as keeping a double set of books, making false entries or alterations, or false invoices or documents, destruction of books or records, concealment of assets or covering up sources of income, handling of one's affair to avoid making the records usual in transactions of this kind, and any conduct, the likely effect of which would be to mislead or to conceal. If the tax evasion motive plays any part in such conduct the offense may be made out even though the conduct may also serve other purposes such as concealment of other crime.*" (Emphasis added.)

In *First Trust & Savings Bank v. United States*, 206 Fed. (2d) 97, a case holding that only the 25% penalty for the *willful failure* to file income tax returns was proper, noting the distinction between the felony section of the Internal Revenue Code (Section 145 (b) and the misdemeanor section of the Internal Revenue Code (Section 145 (a) and citing the *Spies* case, *supra*, held that the "*willful failure* to file returns by the taxpayer did not justify the imposition of the 50% penalty imposed by Section 293 (b) Internal Revenue Code of 1939 as contended by the defendant, but was penalized

by the 25% penalty imposed by Section 291 (a), Internal Revenue Code. Mr. Powell paid the 25% penalty and the propriety of its imposition is not questioned. In the case cited immediately preceding the Court in emphasizing this distinction said:

“But although this case comes to us as one of *first impression with no cited precedent* to support the judgment so far as the identical issue is concerned, the teaching of the opinions that have been handed down with controlling authority in criminal cases establishes that in the “structure of civil and criminal sanctions” which Congress has provided for collection of income taxes, *the “wilful failure” to file returns by the taxpayer in this case must be held to fall in the category of lesser civil derelictions calling for the smaller “addition to tax”* as well as constituting a minor and not a major criminal offense. The applicable principles were clearly defined by the Supreme Court in *Spies v. United States*, 317 U.S. 492, and in the opinion of this court in *Cave v. United States*, 159 Fed. (2) 464. (Emphasis added.)

\* \* \* \* \*

“*The distinction between the lesser and the graver derelictions which govern the larger and the smaller civil additions to tax is of exactly the same character as that found by the Supreme Court in respect to the criminal penalties. Manifestly wilful failure to file returns may have the same effect on the collection of the revenue as an attempt to evade a tax. But Congress makes the difference on the civil side as it does on the criminal side, between the taxpayer whose deficiencies of tax are due to (or caused by) his affirmative commission of fraud and the one whose deficiencies of tax due to wilful omission to make returns. That omission justifies the addition of 5 per cent up to 25 per cent of the deficiencies found against the taxpayer but does not afford any basis for the addition of 50 per cent to his deficiencies. Only the commission of acts of fraud with*

intent to evade tax to which "the deficiencies are due" (or which bring about the deficiencies) affords a basis for the 50 per cent addition to tax. (Emphasis added.)

"The teaching of the opinion of this court in *Cave v. United States*, 159 Fed. (2) 464 is to the same effect as that of the Supreme Court in the *Spies* case."

### **The Imposition of the Fraud Penalty Requires Wilful Commission**

The only prior precedent on the issues raised by this appeal hold that the "wilful omission" to make a return justifies the 25% penalty but does not justify the imposition of the 50% penalty. Reemphasizing the *First Trust and Savings Bank* case, supra, we requote:

"But Congress makes the difference on the civil side as it does on the criminal side, between the taxpayer whose deficiencies are due to (or caused by) his *affirmative commissions of fraud* and the one whose deficiencies are due to *wilful omission to make returns*. That *omission* justifies the addition of the 5 per cent up to the 25 per cent of the deficiencies found against the taxpayer but does not afford any basis for the addition of 50 per cent to his deficiencies. Only the commission of acts of fraud with intent to evade tax to which "the deficiencies are (or which bring about the deficiencies) affords a basis for the 50 per cent addition to tax." (Emphasis added.)

A reading of the opinion (R. 77-84) does not disclose a single finding of *wilful commission* as those words are defined in the *Spies* case, supra. The Supreme Court of the United States said:

". . . By way of illustration, and not by way of limitation, we would think affirmative wilful at-

tempt may be inferred from conduct such as keeping a double set of books, making false entries or alterations, or false invoices or documents, destruction of books or records, concealment of assets or covering up sources of income, handling one's affairs to avoid making the records usual in transactions of this kind, and any conduct the likely effect of which would be to mislead or to conceal. . . ."

The Court below made a direct finding that there was no evidence of such conduct (R. 81). In passing on this element of evidence the court said:

"There is no evidence in the record of *alteration* or *concealment* of bank statements, cancelled checks or real estate contracts by the taxpayer. Mr. Powell said he did not have records, and there is no evidence of these having been *destroyed* or falsely made. . . ." (Emphasis added.)

Note that the court found records were available to reconstruct the taxpayer's income as he had recorded his real estate transactions in the public records showing that he made no attempt to conceal his principal activity (R. 77-78).

It is interesting to note that the court below went on to say (R. 81):

". . . However, there is no need for him to make false records or destroy records in contemplation of an investigation by the Internal Revenue Service, when the taxpayer wasn't making or filing any income tax returns."

This statement seems pregnant with an assertion that all that is necessary for the imposition of the 50% fraud penalty was the failure to file tax returns.

Fraud in a case of this character must be established

by clear and convincing proof, *Rogers v. Commissioner*, 111 Fed. (2d) 897; *Jemison v. Commissioner*, 45 Fed. (2d) 4; *Owens v. U. S.*, 98 Fed. Supp. 621, *Affd.* 197 Fed. (2d) 450. The burden of establishing fraud by *clear and convincing evidence is upon the defendant.* *Ohlinger v. U. S.*, 219 Fed. (2d) 310. The fraud mentioned in the statute must be an overt wrongdoing with intent to *evade a tax* believed to be owing. *Mitchell v. Commissioner*, 118 Fed. (2d) 308; *Wisley v. Commissioner*, 185 Fed. (2d) 263.

The *First Trust and Savings Bank* case, *supra*, is on all fours with this case. In that case, the taxpayer paid the fraud penalty asserted and sued out a claim for refund of said penalty. Taxpayer in that case failed to file income tax returns for eight years, even though he had taxable net income comparable to O. E. Powell. His records were comparable to those kept by O. E. Powell. His cancelled checks and deposit records were available at the bank as were those of O. E. Powell. He was informed against under Section 145 (a) Internal Revenue Code for wilfully failing to make an income tax return required of him for 1945, to which information he pleaded guilty and was sentenced.

The Court of Appeals for the 8th Circuit in commenting on the evidence said:

“There was no proof of any wilful commission of any *affirmative act* of fraud on the part of the taxpayer to evade the taxes which he admitted he owed and ought to have filed return for during the years in question. His plea of guilty to the charge of wilfully failing to make and file return was of course evidence against him of the elements of that charge.

It was compatible with all the other evidence in the case that his dereliction consisted only in *wilful omission and passive neglect* to perform the duty of making returns imposed upon him by law." (Emphasis added.)

The court in holding that the 50 per cent fraud penalty was improper said:

" . . . Congress distinguishes between the taxpayer who is guilty of mere *passive failure* to perform his duty in respect to a tax owing by him and the taxpayer is guilty of *affirmative attempt* or practice of fraud to evade such tax. Though 25 per cent addition to tax was correctly added to Mr. Kraftmeyer's deficiencies because he *wilfully failed and continued to fail to make returns* required of him, the 50 per cent assessment was erroneously made because his dereliction was *passive and included no affirmative act of fraud that caused his tax deficiency. His deficiencies were not 'due to fraud with intent to evade tax'.*" (Emphasis added.)

It is significant that this court required an *affirmative act* as distinguished from mere *passive conduct*, and made the finding that the taxpayer "wilfully failed and continued to wilfully fail to make returns required of him." The court below in distinguishing the present case from the *First Trust and Savings Bank* case remarked:

"The case cited and the present case differ in that the taxpayer (Mr. Kraftmeyer) in the *First Trust and Savings Bank* case, *wilfully failed to make returns* required, had never been informed that he was required to file a return, and apparently was under the impression that he had no taxable income, and did not know that he owed any tax. . . ."

These observations are in part incompatible because if the taxpayer in that case *wilfully failed* to file a return he would have to know he was required to file and had



taxable income. The court made a direct finding that he wilfully failed to file income tax returns and he pleaded guilty to a criminal charge under Section 145 (a), Internal Revenue Code, for wilfully failing to file income tax returns.

An examination of the record fails to disclose a scintilla of evidence establishing a *wilful commission* of an act on the part of O. E. Powell as distinguished from *passive conduct*. The only evidence offered by the government was a failure of Mr. Powell to keep formal books and records and a claimed failure of cooperation. However, the failure to cooperate in 1948, 1949 and 1950 does not in itself establish an active wilful commission as distinguished from passive conduct from 1937 through 1945. In the *First Trust & Savings Bank Case*, supra, Kraftmeyer also failed to maintain books and records and gave false answers regarding duplicate copies of his tax return, implying to the examining agent that he had such documents. This fact is incompatible with Kraftmeyer's assertion that he did not know he owed taxes and his ignorance of his requirement to file returns.

The records of this present proceeding is bare of any evidence of "some wilful commission." The defendant has failed to sustain his burden of proof, *Ohlinger v. United States*, supra, by clear and convincing evidence, *Rogers v. Commissioner*, supra; *Jemison v. Commissioner*, supra. Since there has not been a "wilful commission" as distinguished from "passive conduct" this case should be governed by the same rationale as employed in *First Trust and Savings Bank* case, supra, in which case the court held:

"In the *Spies* case, the conviction for felonious attempt to evade tax was reversed because the necessary showing of 'some wilful commission' was lacking."

\* \* \* \* \*

"There is the same necessity to distinguish between the two kinds of dereliction of taxpayers for which Congress has provided different percentages of addition to tax. The same reasoning establishes that the lesser 5 to 25 per cent additions to tax provided in respect to 'deficiencies due to negligence or intentional disregard of rules and regulations' or for 'failure to make and file return \* \* \* due to wilful neglect' by sections 293 and 291, were applicable to the taxpayer in this case."

## CONCLUSION

For the reasons stated above the imposition of the 50% fraud penalty was improper for the mere failure on the part of the taxpayer to file income tax returns for the years 1937 through 1945, inclusive and the Appellee failed to prove by clear and convincing evidence any acts of commission which would sustain the imposition of the 50% fraud penalty as imposed by Section 293 (b), Internal Revenue Code of 1939. That portion of the judgment below denying Appellant recovery of the penalties imposed and paid should be reversed.

HUMPHREYS & JONES,  
ARTHUR D. JONES,  
904 Yeon Building,  
Portland 4, Oregon,

FREDERICK A. JAHNKE,  
815 Executive Building,  
Portland 4, Oregon,

Attorneys for Appellant.

In the United States Court of Appeals  
for the Ninth Circuit

---

GRACE M. POWELL, EXECUTRIX OF THE ESTATE OF  
O. E. POWELL, DECEASED, APPELLANT

v.

RALPH C. GRANQUIST, DISTRICT DIRECTOR OF  
INTERNAL REVENUE, APPELLEE

---

On Appeal from the Judgment of the United States  
District Court for the District of Oregon

---

BRIEF FOR THE APPELLEE

---

FILED

AUG - 7 1957

PAUL P. O'BRIEN, CLERK

CHARLES K. RICE,  
*Assistant Attorney General.*

LEE A. JACKSON,

DAVIS W. MORTON,  
*Attorney,  
Department of Justice,  
Washington 25, D. C.*

CLARENCE E. LUCKEY,  
*United States Attorney.*

---

---



## INDEX

	Page
Opinion below .....	1
Jurisdiction .....	1
Question presented .....	3
Statutes involved .....	3
Statement .....	3
Summary of argument.....	11

### Argument:

The District Court's finding and conclusion—viz., that Ora E. Powell's failure to file any federal income tax returns for the years 1937 through 1945 was knowing, willful, intentional and due to fraud with intent to evade tax, within the meaning of Section 293(b) of the Internal Revenue Code of 1939—is supported by clear and convincing record evidence and, accordingly, should not here be reversed as "clearly erroneous".....	17
Conclusion .....	35
Appendix .....	36

## CITATIONS

### Cases:

<i>Acker v. Commissioner</i> , 26 T.C. 107.....	24, 32
<i>First Trust &amp; Savings Bank v. United States</i> , 206 F. 2d 97.....	13, 16, 21, 25, 33
<i>Hargis v. Goodwin</i> , 221 F. 2d 486.....	23
<i>Helvering v. Mitchell</i> , 303 U.S. 391.....	18, 19, 23
<i>Ohlinger v. United States</i> , 219 F. 2d 310.....	23
<i>Powell v. Granquist</i> , 149 F. Supp. 308.....	1
<i>Rogers v. Commissioner</i> , 111 F. 2d 987.....	23
<i>Schwarzkoft v. Commissioner</i> , decided July 10, 1957 .....	33
<i>Spies v. United States</i> , 317 U.S. 492.....	12, 18, 23, 24, 33
<i>United States v. Kafes</i> , 214 F. 2d 887, certiorari denied, 348 U.S. 887.....	22
<i>United States v. Smith</i> , 206 F. 2d 905.....	22

### Statutes:

#### Internal Revenue Code of 1939:

Sec. 291 (26 U.S.C. 1952 ed., Sec. 291).....	36
Sec. 293 (26 U.S.C. 1952 ed., Sec. 293).....	36
Sec. 1112 (26 U.S.C. 1952 ed., Sec. 1112).....	33

## Statutes—Continued

Page

Revenue Act of 1936, c. 690, 49 Stat. 1648:

Sec. 291 ..... 37

Sec. 293 ..... 3, 17, 37

Revenue Act of 1938, c. 289, 52 Stat. 447:

Sec. 291 ..... 37

Sec. 293 ..... 3, 17, 37

**In the United States Court of Appeals  
for the Ninth Circuit**

---

No. 15,447

GRACE M. POWELL, EXECUTRIX OF THE ESTATE OF  
O. E. POWELL, DECEASED, APPELLANT

*v.*

RALPH C. GRANQUIST, DISTRICT DIRECTOR OF  
INTERNAL REVENUE, APPELLEE

---

On Appeal from the Judgment of the United States  
District Court for the District of Oregon

---

**BRIEF FOR THE APPELLEE**

---

**OPINION BELOW**

The opinion (R. 77-84) of the District Court is reported at 149 F. Supp. 308. The District Court's findings of fact (R. 84-87) and conclusions of law (R. 87-88) are not officially reported. -

**JURISDICTION**

This appeal involves 50% civil fraud penalties in the amount of \$12,880.39 assessed against Ora E. Powell for the years 1937 through and including 1945 in addition to deficiencies assessed against him for the same years in the amount of \$25,760.74. ( R.

85). The assessed deficiencies are conceded by appellant to be correct (R. 85); the fraud penalties, which were not conceded (R. 84-85), represent the only amount here in issue (R. 162-163). All of the amounts here in controversy, as well as the assessed deficiencies, interest, 25% penalties for willful failure to file returns, 10% penalties for failure to file declarations of estimated tax, and 6% penalties for substantial understatement of estimated tax (R. 22, 68, 84-84), were paid by the appellant and/or Ora E. Powell (R. 70). On July 13, 1954, Ora E. Powell filed claims for refund for the total amount (R. 68) paid (R. 70), which were disallowed, in full (R. 70). Within the time provided in Section 3772 of the Internal Revenue Code of 1939 and on December 15, 1954, appellant brought an action in the District Court for recovery of the amounts paid. (R. 3-57.) At the trial below, the deficiencies, 25% penalties, and 10% penalties were conceded, with only the 50% civil fraud penalties, and 6% penalties for substantial underestimate of estimated tax being timely put in issue. (R. 84-85.) Jurisdiction was conferred on the District Court by 28 U.S.C., Section 1340. The judgment of the District Court<sup>1</sup> was

---

<sup>1</sup> The District Court below decided the 50% civil fraud issue in favor of the Director (Conclusion 4, R. 87-88) and decided the 6% penalty issue for substantial underestimates of estimated tax in favor of the taxpayer (Conclusions 5, 6, R. 88), granting judgment therefor in the amount of \$1,200.55, plus interest (R. 89). No appeal has been taken by the District Director with respect to the 6% penalty issue and, accordingly, the 50% civil fraud penalty issue is the only issue here on appeal.



entered on December 21, 1956. (R. 89). Within sixty days, on or about January 9, 1957, notice of appeal was filed by taxpayer's executrix. (R. 90.) The jurisdiction of this Court is invoked under the provisions of 28 U.S.C., Section 1291.

### QUESTION PRESENTED

Did the District Court err in finding and concluding that Ora E. Powell's failure to file any federal income tax returns for the years 1937 through 1945 was knowing, willful, intentional, and due to fraud with intent to evade tax, within the meaning of Section 293 (b) of the Internal Revenue Code of 1939? <sup>2</sup>

### STATUTES INVOLVED

The pertinent statutes involved are set forth in the Appendix, *infra*.

### STATEMENT

The pertinent facts, as agreed (R. 67-70), as found by the District Court (R. 84-87), and, as set forth in the District Court's opinion (R. 77-82), appear, as follows:

The taxpayer, Ora E. Powell, was, throughout the taxable years 1937 through 1945 and until his death

---

<sup>2</sup> Section 293(b) of the Revenue Act of 1936, c. 690, 49 Stat. 1648, and Section 293(b) of the Revenue Act of 1938, c. 289, 52 Stat. 447, are identical to Section 293(b) of the Internal Revenue Code of 1939. For purposes of simplicity, the question is keyed to the 1939 Code provision, although the equivalent provisions of the earlier Revenue Acts apply with equal force to the years 1937 and 1938, here before the Court of appeal.

on or about July 16, 1954, a citizen and resident of Multnomah County, State of Oregon. (R. 67.) Grace M. Powell, the appellant herein, is the duly appointed qualified executrix of taxpayer's estate. (R. 84.)

The taxpayer did not file any federal income tax returns for the years 1937 through 1945 and also failed to file declarations of estimated tax for the years 1943 through 1945. (R. 77, 85.) At the beginning of this period, however, on May 10, 1937, he filed delinquent federal income tax returns for the taxable years 1933 to 1936, inclusive, with the then Collector of Internal Revenue for the District of Oregon (R. 69). During the taxable years 1937 through 1945, inclusive (for which no federal income tax returns were filed), taxpayer, in each year, had taxable income in amounts<sup>3</sup> giving rise to agreed total deficiency assessments and penalties in the following amounts, with only the 50% civil fraud penalties being contested for purposes of this appeal (R. 68, 85):

---

<sup>3</sup> Witness Daniel S. Forsberg, the Internal Revenue Agent who made the original investigation of Ora E. Powell's taxable years 1937 through 1949, testified (R. 117) that the total amount of taxable income computed for such years was "In excess of \$118,000.00." Taxpayer protested this finding (R. 118, 129-130) and on re-examination, the agreed amount of total taxable income giving rise to the total agreed deficiency of \$25,760.74 was developed. Because expenses were allowed in additional amounts this re-computed total agreed taxable income was somewhat lower than the original amount computed but the record does not indicate the exact amount. (See testimony of the Director's witness Edward A. Maier, R. 132.)

Year	Conceded Deficiencies In Income Tax	Conceded 25% Penalties for Wilful Failure to File Income Tax Returns	Conceded 10% Penalties for Failure to File Declarations of Estimated Tax	Contested 50% Civil Fraud Penalties, Assessed Under Section 293(b) of the 1939 Code, Which Are Here In Issue
1937	\$ 100.99	\$ 25.25	-----	\$ 50.50
1938	102.10	25.23	-----	51.05
1939	76.82	19.21	-----	38.41
1940	590.16	147.54	-----	295.08
1941	1,027.81	256.95	-----	513.91
1942	3,853.66	963.42	-----	1,926.83
1943	2,520.25	630.06	\$ 252.03	1,260.13
1944	11,426.55	2,856.64	1,142.66	5,713.28
1945	6,062.40	1,515.60	606.25	3,031.20
	<u>\$25,760.74</u>	<u>\$6,439.90</u>	<u>\$2,000.93</u> <sup>4</sup>	<u>\$12,880.39</u>

The failure of the taxpayer to file returns came to the attention of the Internal Revenue Service in January, 1946, whereupon an investigation was begun to determine Ora E. Powell's taxable income for the years 1937 through 1945. (R. 77.) When asked for his records, "Mr. Powell said he did not have records". (R. 81.)<sup>5</sup> In order to determine tax-

<sup>4</sup> The difference between this amount and the figure of \$3,201.48 (R. 68) is the amount of \$1,200.55, recovered by taxpayer under the District Court judgment below and not before this Court on appeal (R. 89).

<sup>5</sup> See direct testimony of Harold Parsons, Internal Revenue Agent (R. 108):

- Q. Why didn't you go to Mr. Powell's records and find that information?
- A. We requested records from Mr. Powell and he stated that he had not kept records of his real estate transactions.
- Q. Did he state whether or not he had kept records during the period in issue, 1937 to 1945?
- A. That was the only period for which we requested records, the period under investigation.

payer's income it was necessary that the Internal Revenue Agents search public records in four counties, examine Powell's sons' records, and contact real estate dealers and other parties to various business transactions of the taxpayer, including the company from which he purchased gasoline. (Finding 8, R. 86.)<sup>6</sup>

- 
- Q. Did he state that he did or did not keep records during that period?
- A. That he did not keep records during the period we were investigating.

<sup>6</sup> See direct testimony of Harold Parsons, Internal Revenue Agent (R. 107-108, 108-109):

- Q. What was the nature of your investigation?
- A. Gathering evidence to determine the tax liability of Ora E. Powell.
- Q. How did you go about determining that tax liability?
- A. Among other things examined the County records of Multnomah County, Washington County, Marion County, and Clackamas County, the deed and mortgage records to determine the purchase and sale of real estate by Ora E. Powell.

\* \* \* \*

- Q. How long did your investigation take?
- A. From June of '46 to October of '47, probably during that time we would spend between thirty and forty working days.
- Q. Did Mr. Powell ever make any documents or information available to you?
- A. There were some real estate sales on contract, and when we would discover such sales we would request that he bring in the contracts so that we could determine the amount of payments on the contract and the interest. When he was specifically asked for a certain contract he would bring it in.
- Q. Aside from the contracts specifically requested one at a time, was there any documents or information made available to you by Mr. Powell?
- A. No, not to me.

During the years 1937 to 1945, taxpayer owned and operated a number of gasoline service stations, later leasing them to his two sons, Lee G. Powell and Vincent O. Powell, receiving from them rental income. In addition, taxpayer had, at various times during the period, 19 different properties that he rented, and also, during that time, had made in excess of 30 real estate sales of farms and residences, receiving interest income on contracts and commissions from realty sales. (R. 77.)

Whereas the records taxpayer kept were adequate for him to carry on his business profitably (R. 81), he did not keep books and records adequate to show his income during the years 1937 through 1945 (Finding 8, R. 86). He never volunteered any records, information or contracts. It was only as various transactions were discovered by the Internal Revenue Agents and specific requests were made for all records and documents pertinent thereto that they were made available by the taxpayer. (R. 81.)<sup>7</sup>

---

<sup>7</sup> See direct testimony of Daniel S. Forsberg, Internal Revenue Agent (R. 114-115):

- Q. Now, on the occasion of your first contact with Mr. Powell, your first personal contact, what did he say and what did you say?
- A. Mr. Powell came in after the filing period in March—he had been out of State—he didn't have his copies of returns with him and he advised me at that time that he had not filed income tax returns since 1936.
- Q. Did you request Mr. Powell to furnish you with any records?
- A. My next question then was to furnish me with the books and records by which I might determine whether he had a tax liability or not.
- Q. Did Mr. Powell produce such books and records?

He gave evasive answers to the Internal Revenue Agents who were attempting to ascertain his taxable income for the years 1937 through 1945 and did not co-operate with the agents in their investigation. (Finding 10, R. 87.)

Taxpayer was aware of his obligation to file federal income tax returns, having filed such returns for years prior to 1937.<sup>8</sup> He was advised by an employee of the Oregon State Tax Commission<sup>9</sup> and by

- 
- A. He advised me that he had never kept any books or records during that period of time.
- Q. What was the next step in your investigation?
- A. Then I asked Mr. Powell regarding bank statements and cancelled checks. He had an account at the First State Bank of Milwaukee and at my request he produced cancelled checks and bank statements for all years in question. Checks were missing for the first half of 1937 only.

See also the direct testimony of witness Harold Parsons, set forth in footnote 6, *supra*.

<sup>8</sup> See testimony of Daniel S. Forsberg, Internal Revenue Agent, on cross-examination (R. 125):

- Q. During the course of your investigation, did you find that Mr. Powell had filed Federal income tax returns prior to the taxable year 1937?
- A. Yes.
- Q. For what years?
- A. Delinquent returns were received in the Collector's office in May, 1937, for the years 1933, 1934, 1935 and 1936.

<sup>9</sup> See testimony of Carl P. Armstrong, Portland office manager of the Oregon State Tax Commission (R. 99):

- Q. Did you say anything to him [Powell] about Federal Income Tax returns?
- A. Yes; upon completion of our investigation of the records that he had for the years 1935 and '36 and also '37, we indicated to him at that time that he

one of his sons<sup>10</sup> to file federal income tax returns. (Finding 6, R. 86.)

Taxpayer made statements to Internal Revenue Agents in 1946 and 1947 to the effect that his failure to file income tax returns was based upon his disagreement with the way the country was being run and that he did not believe in paying taxes.<sup>11</sup> He

---

also had a tax liability to the Federal Government. This procedure was followed in all cases of our investigation because of the method used by the State Tax Commission, which was to familiarize the taxpayer with their responsibility and also to indicate to them the responsibility they might have to the Federal Government in that respect.

<sup>10</sup> See direct testimony of Lee G. Powell, taxpayer's son (R. 141):

Q. During those years in question, was the subject of taxes ever discussed?

A. Yes.

Q. What statements did he make to you, during those years, concerning income taxes?

A. I knew that he wasn't paying his income tax and I asked him about it and told him that he should be paying, that it was the thing for him to do, and he said he knew it but that he didn't pay because he didn't believe in the way the Government was wasting the money.

<sup>11</sup> See direct testimony of Harold Parsons, Internal Revenue Agent (R. 109):

Q. Did Mr. Powell ever state to you at any time his reason for failure to file income tax returns for the years 1937 to 1945?

A. Yes.

Q. What reasons did he state?

A. On at least two occasions he made the statement that he was not in sympathy with the administration and did not like the way the Government was run and did not believe in paying income taxes.

made statements to one of his sons that the reason he did not pay taxes was that he believed the Government was wasting money.<sup>12</sup> (Finding 7, R. 86.) He further indicated that he was thinking of getting his things gathered together and moving out of the country—going to South America where he would not have to pay taxes. (R. 80.)<sup>13</sup>

On or about March 9, 1948, the United States filed an Information against Ora E. Powell pursuant to Section 145(a) of the Internal Revenue Code of 1939 asserting that for the calendar years 1944 and 1945 taxpayer wilfully, knowingly and unlawfully failed to make income tax returns and, on May 24, 1949, taxpayer entered a plea of guilty to such charge. (R. 70; Finding 9, R. 86.)

Specifically finding (No. 11, R. 87) and concluding as a matter of law (Conclusion 4, R. 87-88) that the agreed deficiencies for the years 1937

---

<sup>12</sup> See footnote 10, *supra*.

<sup>13</sup> See direct testimony of Daniel S. Forsberg, Internal Revenue Agent (R. 119-130):

Q. Did Mr. Powell ever state to you, at any time, any reason for his failure to file income tax returns for the years 1937 to 1945?

A. Yes.

Q. What was the reason he gave?

A. At least on two occasions and in the presence of the joint examining special officer, Parsons, the taxpayer said that he didn't believe in the way the Country was being run and he didn't believe in paying income taxes, and he was strongly thinking of getting his things gathered together and moving out of the country and going to South America where he didn't have to pay taxes.



through 1945 were due to fraud with intent to evade tax, within the meaning of Section 293(b) of the Internal Revenue Code of 1939, the District Court pointed out in its opinion (R. 81):

There is no evidence in the record of alteration or concealment of bank statements, cancelled checks or real estate contracts by the taxpayer. Mr. Powell said he did not have records, and there is no evidence of these having been destroyed or falsely made. However, there was no need for him to make false records or destroy records in contemplation of an investigation by the Internal Revenue Service, when at that time the taxpayer wasn't making or filing any income tax returns. The same thing is true of concealment of assets and the other "badges of fraud" to which reference has been made. The mere fact that these acts were not apparent at the time he was failing to make returns does not mean they didn't exist.

#### SUMMARY OF ARGUMENT

The District Court correctly found and held that taxpayer's failure to file any federal tax returns and to pay any tax during the nine consecutive years, 1937 through 1945, was knowing, willful, intentional and "due to fraud with intent to evade tax", within the meaning of Section 293(b) of the Internal Revenue Code of 1939 (and the identical provisions of Section 293(b) of the Revenue Acts of 1936 and 1938, which apply here with equal force to the taxable years 1937 and 1938). This express finding and conclusion is compellingly supported by clear and convincing record evidence and, accordingly,

should not here be reversed as clearly erroneous. Under all the facts obtaining, the 50% civil additions to tax, amounting in total to \$12,880.39, were properly assessed for the years in issue.

“If any part of any deficiency is due to fraud with intent to evade tax”, Section 293(b) provides that 50% of the deficiencies shall be added thereto as a civil addition to tax. The statute is remedial in nature. In applying it, a court is not dealing with common law fraud; neither is it dealing with criminal fraud, which is specifically treated in Section 145(a) and (b) of the 1939 Code, which imposes fines and imprisonment as criminal sanctions against willful failure to pay tax (a misdemeanor) and willful attempt to evade or defeat tax (a felony). On the contrary, Section 293(b) enunciates a statutory concept of “fraud with intent to evade tax”, which, unlike a penalty, involves the imposition of no criminal sanctions but, instead, provides for the assessment of a civil addition to the tax deficiency.

There is a basic and fundamental distinction which obtains between the justifiably strict and constitutionally safeguarded criminal felony test for fraud, applied in imposing fines and imprisonment under Section 145(b), and the civil test properly applicable in the assessment of additions to tax under Section 293(b), which distinction is highlighted in cases, such as this, where there has been a consistent failure to file returns and pay tax, continued over a period of years. The Supreme Court has laid down the criminal test in *Spies v. United States*, 317 U. S. 492, pointing out that Section 145(a), the misdemeanor

statute, expressly applies to the situation of a willful failure or omission to file returns and/or pay tax, so that its Congressional purpose of enactment would be frustrated if something more—viz., an affirmative act of fraud—were not required to warrant conviction for a felony (carrying a much higher fine and possible imprisonment for 10 years) under Section 145(b). Justification for such a strict criminal fraud test is found in our traditional aversion to imprisonment for debt and in the constitutional necessity for safeguarding individual rights and immunities in criminal cases, as well as in the distinction between the Government's burden of proving a criminal felony beyond a reasonable doubt as opposed to the burden of proving the civil addition to tax by clear and convincing evidence.

Here, the taxpayer makes no effort to refute the record evidence, which stands uncontroverted, and attempts erroneously, instead, to apply to the civil assessment of additional tax, under Section 293(b), the criminal felony test of the *Spies* case, *supra*. In addition, to *Spies*, taxpayer relies on *First Trust & Savings Bank v. United States*, 206 F. 2d 97 (C.A. 8th), a case in which a majority of the Eighth Circuit, we submit erroneously, invoked the *Spies* criminal felony test in a civil case, clearly distinguishable on its facts from the instant case, but involving a failure—viz., “passive omission”—to file returns and pay federal tax. In attempting to argue that the justifiably strict criminal differentiation between Section 145(b), the felony, and Section 145 (a), the misdemeanor, should be applied, on the civil

side, to Section 293(b), the 50% civil addition to tax, and Section 291(a), the 5% to 25% civil addition to tax for failure to file a return, the taxpayer, apart from the fundamental objections which obtain to make such a strained analogy inapplicable, overlooks the express statutory language of Section 291(a), which, unlike Section 145(a), is not predicated on willful failure to pay but is limited in its applicability to the single circumstance of failure to file a return. Accordingly, under the statutory pattern, Section 293(b) is the additional civil assessment which is predicated directly on willful failure to pay taxes known to be owing. Since the proscribed failure to pay must be due to "fraud with intent to evade", and the evasion may result from either total or partial concealment from the taxing authorities of such known tax liability, it follows that a total concealment, such as here obtained, will result in a higher civil addition to tax than a partial concealment (with a return being filed which willfully understates taxable income). Section 293(b) provides for this by measuring the assessment of additional tax on the amount of the deficiency.

In the instant case, the uncontroverted evidence spread on the record furnishes more than ample clear and convincing proof to support the District Court's finding that the assessed deficiencies for the years 1937 through 1945 were knowing, willful, intentional, and due to fraud with intent to evade tax, within the meaning of Section 293(b) of the 1939 Code. Taxpayer, by his own express admissions, was aware of his responsibility to file returns for the years in

question and had, in fact, filed federal tax returns for prior years; that such failure to file was willful and knowing was both admitted by himself and evidenced by his plea of guilty to such a charge in connection with his conviction under Section 145(a), in a separate criminal proceeding. Taxpayer's educational background, his varied business activities, successfully conducted, his activities as a real estate broker, and his admission that the assessed deficiencies were correct in amount cumulatively and compellingly evidence his awareness that he received taxable income in substantial amounts throughout the period, which he never voluntarily reported. In other words, his willful failure to file returns acknowledging his responsibility to pay taxes which he had every reason to know were due and owing on substantial amounts of total taxable income received over nine consecutive years, coupled with his concession that the deficiencies assessed therefor were correct, amounted to an admission that such deficiencies, representing evaded taxes, were due to his willful concealment or fraud. In addition, taxpayer failed to keep adequate books or records reflecting his true tax liability, persisted in giving evasive answers to the investigating officers, and was altogether uncooperative throughout their basic investigation of his business and financial affairs. Indeed, it would be difficult to designedly construct a record more replete with clear and convincing evidence of taxpayer conduct warranting a finding that assessed deficiencies were due to fraud with intent

to evade tax. In this connection, the law is clear that, for purposes of Section 293(b), the willful purpose to fraudulently evade tax may properly be inferred from any conduct calculated to mislead or conceal, including a willful failure to file any returns whatsoever under circumstances where the failure is consistent over a number of years and the amount of income, willfully omitted, is substantial.

Finally, apart from its erroneous adoption of the *Spies* criminal felony test in interpreting the applicability of Section 293(b) in a civil proceeding to assess additional tax, the Eighth Circuit majority's opinion in *First Trust & Savings Bank v. United States, supra*, is in no way here controlling. The *First Trust & Savings Bank* case is clearly distinguishable on its facts, having involved a taxpayer who had never in his life, prior to investigation, filed returns, kept records, or been aware of his obligation to file federal returns. While he had heard of the income tax, he was unaware that he had a return on his investment which represented taxable income and, accordingly, did not know that he owed any tax. When investigated, he hired an attorney and cooperated fully with the authorities. Under these circumstances, the Court's finding that he had no fraudulent intent was buttressed by the investigating officer's testimony that he had made no effort to conceal.

## ARGUMENT

The District Court's Finding and Conclusion—viz., That Ora E. Powell's Failure To File Any Federal Income Tax Returns for the Years 1937 Through 1945 Was Knowing, Wilful, Intentional and Due To Fraud With Intent To Evade Tax, Within the Meaning of Section 293(b) of the Internal Revenue Code of 1939<sup>14</sup>—Is Supported By Clear and Convincing Record Evidence and, Accordingly, Should Not Here Be Reversed As "Clearly Erroneous"

The single issue presented on this appeal is whether the District Court correctly held, under all the facts obtaining, that (R. 87-88) 50% civil additions to tax, in the amount of \$12,880.39 (R. 85), were properly assessed against Ora E. Powell for the taxable years 1937 through 1945. We submit that they were and that the District Court was amply justified in finding (No. 11, R. 87) and concluding (Conclusion 4, R. 87-88) that Powell's failure to file any federal income tax returns for those nine consecutive years was due to fraud with intent to evade tax, within the meaning of Section 293(b) of the Internal Revenue Code of 1939 (Appendix, *infra*).

Section 293(b) of the 1939 Code provides that "If any part of any deficiency is due to fraud with

---

<sup>14</sup> Section 293(b) of the Revenue Act of 1936, c. 690, 49 Stat. 1648, and Section 293(b) of the Revenue Act of 1938, c. 289, 52 Stat. 447, are identical to Section 293(b) of the Internal Revenue Code of 1939. For purposes of simplicity, reference is only made to the 1939 Code section throughout the Argument, although the equivalent provisions of the earlier Revenue Acts apply with equal force to the years 1937 and 1938.

intent to evade tax" then 50% of the deficiency shall be added thereto.

The District Court found (R. 87):

11. The failure of Ora E. Powell to file any federal income tax returns for the years 1937 through 1947 was knowing, willful and intentional, and was due to fraud with intent to evade tax.

In this case, the District Court, in so finding, was not dealing with common law fraud; neither was it dealing with criminal fraud, as provided for in Section 145(a) and (b) of the 1939 Code, which imposes fines and imprisonment as sanctions against wilful failure to pay tax (misdemeanor) and willful attempt to evade or defeat tax (felony). On the contrary, the District Court was dealing with the statutory concept of "fraud with intent to evade tax", which involves the imposition of no criminal sanctions but instead, unlike a penalty, amounts, instead, to the assessment of a civil addition to the tax deficiency. *Helvering v. Mitchell*, 303 U. S. 391, 404-405.

It is, of course, basic to our self-assessed revenue system, as outlined in the 1939 Code, that the penalties (embracing "additions to the tax") imposed by Congress to enforce the tax laws include both civil and criminal sanctions. In this connection, it has long been established that invocation of one sanction does not exclude resort to the others. *Helvering v. Mitchell*, 303 U. S. 391; *Spies v. United States*, 317 U. S. 492. While this is true, it is equally true that fundamental distinctions obtain between the prosecution



of a taxpayer for criminal fraud and the imposition of a civil addition to tax "due to fraud", which is a remedial sanction "provided primarily as a safeguard for the protection of the revenue and to reimburse the Government for the heavy expense of investigation and the loss resulting from the taxpayer's fraud." *Helvering v. Mitchell*, 303 U. S. 391, 401. Thus, in distinguishing, on the criminal side, between the felony prescribed by Section 145(b) and the misdemeanor under Section 145(a), the Supreme Court, in *Spies, supra*, pointed out (p. 498) that:

\* \* \* in view of our traditional aversion to imprisonment for debt, we would not without the clearest manifestation of Congressional intent assume that mere knowing and intentional default in payment of a tax, where there had been no wilful failure to disclose the liability, is intended to constitute a criminal offense of any degree. We would expect willfulness in such a case to include some element of evil motive and want of justification in view of all the financial circumstances of the taxpayer.

So viewed, the Court reversed a criminal conviction under Section 145(b), where there was no evidence before it other than that of the taxpayer's willful failure to file returns and to pay tax. In doing so, however, the Court carefully pointed out (p. 499) that "Congress did not define or limit the methods by which a willful attempt to defeat and evade might be accomplished \* \* \*." Earlier, in the *Mitchell* case, *supra*, the Supreme Court, holding that a criminal

acquittal under Section 145 (b) was not *res judicata* in a subsequent suit to recover Section 293(b) civil fraud additions to the tax, emphasized (pp. 397, 401-404) the fundamental distinctions between a criminal prosecution for fraud and the remedial civil fraud assessment, giving specific mention to burden of proof (pp. 397, 403); collection by distraint (pp. 401-402); and a defendant's constitutional guaranties as to determination of liability (pp. 402-403), the direction of verdicts (pp. 402-403), appeal as of right (p. 403), the right to confront witnesses (pp. 403-404) or to refuse to testify (p. 404), and immunity from double jeopardy (p. 404).

While the *Mitchell* case, *supra*, evidences the obvious fact that a criminal fraud prosecution and an administrative assessment of civil additions to tax "due to fraud with intent to evade tax" may arise out of the same facts, the pains taken by the Supreme Court to delineate the basic distinctions between criminal fraud and the remedial civil fraud assessment serve to highlight the error of taxpayer's attempt (Br. 8-11, 13-14) to import into this civil proceeding the justifiably strict and constitutionally safeguarded criminal fraud test of the *Spies* case, *supra*. As Mr. Justice Jackson pointed out in *Spies* (p. 498) the conviction for the Section 145 (b) felony requires establishment of the taxpayer's "evil motive", which, in turn, requires (p. 499) evidence from which an "affirmative willful attempt may be inferred." Since the conviction is for a felony, with the burden resting on the Government to prove guilt beyond a reasonable doubt, the willful failure to pay tax, which,

in and of itself, satisfies the misdemeanor requirements of Section 145(a), cannot, standing alone, support a felony conviction, carrying a possible 10 year prison sentence, under Section 145(b). -

In discussing the civil additions to tax provided in Sections 291(a) (Appendix, *infra*) and 293(b) of the 1939 Code, Mrs. Powell (Br. 8-13) erroneously attempts to apply the same comparative criminal standards of proof that the Supreme Court enunciated in *Spies, supra*, in differentiating between justifiable conviction for a misdemeanor, under Section 145(a), and, for a felony, under Section 145(b). Ignoring the fundamental distinctions between imposition of the criminal sanctions as opposed to the civil—viz., liability for imprisonment, the penalty concept as opposed to a mere civil addition to tax, the different burdens of proof, the necessity for safeguarding constitutional guarantees in criminal cases, etc.—Mrs. Powell relies (Br. 11-13, 15-18) on the Eighth Circuit's opinion in *First Trust & Savings Bank v. United States*, 206 F. 2d 97, a case in which a majority of that court, as a matter of first impression, adopted the strained analogy to *Spies*, which is here relied on by Mrs. Powell (Br. 12), and concluded (p. 101) that "affirmative commission of fraud", as opposed to "willful omission to make returns", must be proved in order to support the Section 293(b) assessment of additional tax. It would not, we believe, be unfair to say that this constitutes Mrs. Powell's entire case.

Although we believe the *First Trust & Savings Bank* case, *supra*, to be clearly distinguishable from

the instant case on its facts (as we shall demonstrate, *infra*), we submit that the criminal fraud rationale of *Spies, supra*, properly has no direct applicability or controlling force with respect to the correct interpretation here to be accorded Section 293(b). In terms of statutory requirements, the Supreme Court had before it, in *Spies*, a taxpayer's willful omission to file returns and to pay tax, which constituted the precise quantum of proof requisite to conviction of a misdemeanor, under Section 145(a). Accordingly, the Court held that to prove the felony beyond a reasonable doubt, something more—viz., some affirmative act of fraud—must be additionally proved; otherwise, there would have been no purpose in Congressional enactment of Section 145(a), which precisely treated the situation there before the Court.<sup>15</sup> In contrast, the civil additions to tax prescribed by Sections 291(a) and 293(b) represent remedial sanc-

---

<sup>15</sup> In *United States v. Smith*, 206 F. 2d 905 (C.A. 3d) and *United States v. Kafes*, 214 F. 2d 887 (C.A. 3d), certiorari denied, 348 U.S. 887, the Third Circuit was concerned with the types of so-called "affirmative acts" which will support affirmance of convictions under Section 145(b) in cases where there was a failure on the part of the defendant to file tax returns. In *Smith*, Judge Staley included (p. 909) among such "acts or fraud" the fact that "defendant and his corporations received substantial amounts of income and \* \* \* no returns were filed." In *Kafes*, a case where the jury found (p. 891) that defendant had cooperated with the investigators, Judge Goodrich listed (p. 890) defendant's avoidance of making proper books of account and records; his failure to enter some items in the duplicate receipts books that he did finally begin to keep; and the cashing of checks without clearance through his bank account.

tions which do not necessarily overlap in the sense that (Br. 17) "willful commission", as opposed to "passive conduct", is necessary to support a trial judge's finding that deficiencies are "due to fraud with intent to evade tax." While this Court in *Ohlinger v. United States*, 219 F. 2d 310, 313, has held that the burden of proof is on the Government, it is clear that the Government's burden may be satisfied by clear and convincing proof. See *Hargis v. Goodwin*, 221 F. 2d 486, 489 (C.A. 8th); *Rogers v. Commissioner*, 111 F. 2d 987, 989 (C.A. 6th); *Helvering v. Mitchell*, 303 U. S. 391, 403; *Spies v. United States*, 317 U. S. 492, 495. Under Section 291(a) the civil addition to tax, ranging from 5% to 25%, is imposed for failure to file a return without reasonable cause; unlike Section 145(a), the statute does not address itself to failure to pay tax. Section 293(b), on the other hand, is applicable where a part of a deficiency is "due to fraud with intent to evade tax." Accordingly, the two civil sanctions are addressed to different ends. A taxpayer with sufficient taxable income to require the filing of a return might have sufficient deductions, if he filed the return, to avoid the payment of any tax whatsoever. If he willfully omitted to file such a return he would technically be in violation of Section 291(a), or he could be convicted of a misdemeanor, under Section 145(a), since the requirements of that penalty statute are similarly satisfied. But where a taxpayer willfully omits to file a return and the omission results in substantial taxable income never being brought to the attention of the taxing authorities,

as a consideration separate and apart from the Section 291(a) violation, the omission or concealment produces the direct result that tax has been evaded, with the willful purpose to omit the filing of the return serving to warrant the inference of evasion. Pointing to the basic distinction between the criminal and civil sanctions and emphasizing the dependence of our self-assessed revenue system on the rendering of true accounts by taxpayer, the Tax Court stated the proposition, as follows, in *Acker v. Commissioner*, 26 T.C. 107, 112:

Such willful attempt to defeat the statute or evade tax may be inferred from any conduct calculated to mislead or conceal; and it may be found not only in a situation where one of the methods employed was to file an intentionally false return, but also where the method involved a willful failure to make any return whatever. This Court has, in a number of cases, approved the imposition of the sanction under Section 293(b), where no return was filed. See for example, *A. Raymond Jones*, 25 T.C. (Feb. 29, 1956); *Arthur M. Slavin*, 43 B.T.A. 1100, 1110; *Ollie v. Kessler*, 39 B.T.A. 646; *Pincus Brecher*, 27 B.T.A. 1108.

On the basis of the foregoing we submit that, as a matter of law, Mrs. Powell is in error in attempting to ignore the fundamental distinctions between the criminal and the civil sanctions and to read into Section 293(b), on the civil side, the criminal fraud test applied in *Spies v. United States*, *supra*. Proceeding to the facts here obtaining, it would be difficult to construct a more classic example of a case

presenting "clear and convincing" evidence of deficiencies which arose "due to fraud with intent to evade tax", within the meaning of Section 293(b).

The testimony adduced by the Government at the trial is uncontroverted. On brief, Mrs. Powell makes no serious attempt to refute it but rests her entire argument on the theory that (p. 17) there was no willful commission of fraudulent acts by the taxpayer; no alteration, destruction or concealment of records (p. 14); and, as a consequence, the Director had not sustained his burden of proving fraud (pp. 7, 17). While Mrs. Powell pays lip-service (Br. 17) to the established rule that the burden of proof in civil fraud cases requires only "clear and convincing" evidence, her argument (Br. 7-18), as pointed out above, is based on the here inapplicable criminal test of the *Spies* case, as reiterated, we submit erroneously, by the Eighth Circuit majority in *First Trust & Savings Bank v. United States, supra*.

Contrary to Mrs. Powell's mistaken reliance on a criminal felony test for fraud, we submit that the uncontroverted evidence spread on this record is both "clear and convincing" and more than amply supports the trial judge's finding (No. 11, R. 87) that taxpayer's failure to file any federal tax returns for 1937 through 1945 was knowing, willful, intentional, and was due to fraud with intent to evade tax. It would, in fact, be difficult to contrive a factual context which could nearer approximate an express admission of the Section 293(b) violation. As the first element, taxpayer was fully aware of his responsibility to file annual federal income tax returns. In

May 1937, at the beginning of the period under review, he filed delinquent returns for the years 1933, 1934, 1935, and 1936. (R. 125.) In 1938, during the early part of the period, Carl P. Armstrong, of the Oregon State Tax Commission, pursuant to an investigation of his failure to file state tax returns advised taxpayer of his responsibility to file federal tax returns. (R. 99.) Lee G. Powell, taxpayer's son, testified on direct examination that he discussed the matter with his father and advised him to file returns and pay his federal tax. (R. 141-142.) Finally, taxpayer himself advised Revenue Agent Forsberg, in 1946, that he had not filed any federal income tax returns since 1936. (R. 114-115.)

In the second place, the taxpayer was aware throughout the period under review that he had taxable income which he was not reporting. Carl P. Armstrong, of the Oregon State Tax Commission, so advised him at the beginning of the period. (R. 99.) That such taxable income was substantial is evidenced by Revenue Agent Forsberg's computation that, in total amount, it exceeded \$118,000 (R. 117), as well as by taxpayer's agreement, in the pre-trial order and at the trial that, after recomputation, it was sufficient in amount to support agreed deficiencies totaling \$25,760.74. (R. 68, 85). In addition, taxpayer's many and varied business activities compel the inference that he was aware of the successful nature of his commercial affairs. He had the equivalent of a high school education. (R. 138.) Between 1921 (R. 138) and 1941 (R. 142) he built up his gasoline service stations (R. 138), from a



single station to a business comprising seven stations, and, from 1941 until his death, he leased five of these stations to his son on an income-producing basis. (R. 142-143). He acquired a real estate broker's license in 1941 or 1942. (R. 139.)<sup>16</sup> This permitted him to receive commissions in his own right and also by working for other real estate brokers. (R. 117.) At various times during the period, taxpayer had nineteen different properties that he rented and, during that time, he made in excess of thirty real estate sales of farms and residences. (R. 116.) He maintained a bank account with the First State Bank of Milwaukee. (R. 115.) He also maintained an account during the period with the United States National Bank. (R. 114.)

In the third place, although he was aware of his responsibility to file federal returns and knew that he had substantial taxable income during the period, taxpayer admitted that his failure to file was willful. He did so by entering a plea of guilty, on May 24, 1949, to the charge of willfully, knowingly and unlawfully failing to file federal income tax returns for the years 1944 and 1945 in violation of Section 145(a) of the Internal Revenue Code of 1939. (Finding 9, R. 86.) In addition he admitted his willful failure to file throughout the period by telling Revenue Agent Parsons (R. 109) and Revenue Agent Forsberg (R. 119-120) that he did not file federal returns because he did not believe in the

---

<sup>16</sup> Revenue Agent Forsberg testified that Powell acquired such a license in January, 1943. (R. 117.)

way the country was being run, did not believe in paying taxes, and was strongly thinking of moving from Oregon to South America, where he would not have to pay taxes. Lee G. Powell, taxpayer's son, confirmed the fact that taxpayer, as a strong-willed man, did not pay taxes because he did not believe in the way the Government was wasting the money. (R. 141.)

In the fourth place, as the District Court found (Findings 8, 10, R. 86, 87), taxpayer did not keep books and records adequate to show his income during the years 1937 through 1945 and, when confronted by the investigating officers with requests for record evidence of his business transactions, he gave evasive answers and did not cooperate with them in their investigation. When asked for his books and records by Revenue Agent Parsons, taxpayer stated he had not kept any records of his real estate transactions for the period 1937 through 1945. (R. 108.) When contacted by Revenue Agent Forsberg, taxpayer stated again that he kept no books or records, but, upon being questioned as to bank statements and cancelled checks, he produced the same. (R. 115.) When asked generally to produce real estate contracts or other information, taxpayer stated to Agent Forsberg that he did not have them. (R. 119.) As a result of this failure to elicit records of taxpayer's real estate transactions, Revenue Agent Parsons spent between 30 and 40 working days examining the county records of Multnomah, Washington, Marion and Clackamas Counties, examining deeds and mortgages and endeavoring to determine

the nature of taxpayer's purchase and sale transactions. (R. 107-108.) With respect to real estate sales on contract, taxpayer, when asked specifically for a particular contract, would produce it. (R. 108-109.) He did not, however, make other documents or information available when not specifically requested. (R. 108-109.) In connection with determination of taxable income for the period, Revenue Agent Forsberg testified that for the period 1937 to 1941 it was necessary to determine income from the gasoline service station business from bank deposit slips and cancelled checks; there were no other records. During the lease period, 1942-1945, it was necessary to ascertain taxpayer's rental income from examination of the books of his sons, Lee G. Powell and Vincent O. Powell, checked against the sons' income tax returns. Deeds, mortgages and contracts were examined in the four counties previously mentioned and, from the tax roles the agents contacted and interviewed various persons who had purchased or leased realty from the taxpayer. Real estate commissions were test checked against available wage slips and the commission income, in the absence of other records, was estimated. (R. 115-117.) This initial computation, which occupied Agent Forsberg for more than 27 working days and yielded taxable income for the period in excess of \$118,000, was protested (R. 117-118). Former Revenue Agent Edward A. Maier testified that, after the protest, he made the re-examination, in 1950, which resulted in the final computation of taxable income used as a

basis for the agreed deficiencies of \$25,760.74 for the period. (R. 85, 129-130.)

He testified that he worked with an accountant hired by taxpayer and that they reached an accord. (R. 130, 135.) He stated that one of the provisions attaching to taxpayer's plea of guilty in the criminal proceeding was that he cooperate in determining his correct tax liability for the period. (R. 130-131.) Former Agent Maier testified that the agreed deficiencies arrived at were somewhat lower than Agent Forsberg's original computation due to certain expense allowances and the computation of gasoline service station income on the basis of profit per gallon developed from actual sales of gas and oil. (R. 132-133.) Agent Maier testified that his investigation lasted "probably about a week or perhaps a day or two—not over a week." (R. 132.)

Summarizing the foregoing factual analysis, we submit that the uncontroverted evidence clearly and convincingly supports the District Court's finding that the admitted deficiencies of \$25,760.74 for the taxable years 1937 through 1945 were "due to fraud with intent to evade tax" within the meaning of Section 293(b) of the 1939 Code. By express admission to both the Revenue Agents and his son, taxpayer was aware of his responsibility to file returns; by express admission and by pleading guilty in the criminal case under Section 145(a), taxpayer's failure to file was willful and knowing; by direct participation in his varied successful business activities and by express concession that the deficiencies arrived at were correct, taxpayer was aware that he

received taxable income in substantial amounts throughout the period of his willful failure to file and pay. For purposes of the civil addition to tax under Section 293(b), taxpayer's willful failure to file returns acknowledging his liability to pay taxes, which he had every reason to know were due, amounted to a concealment from the taxing authorities of the total amount of taxable income received during the nine consecutive years in issue; acknowledgment of the correctness of the deficiencies amounted to an admission that such deficiencies (amounting to a total evasion of such taxes when due) were due to such concealment. Since the concealment was willful and it produced the result proscribed by Section 293(b)—viz., in this case, complete evasion of tax in substantial amounts—these facts, in and of themselves, furnish clear and convincing proof supporting the District Court's finding of civil fraud. However, in addition, taxpayer failed to keep adequate books or records sufficient to accurately determine his tax liability for the period; he consistently gave evasive answers to the investigating officers which made it difficult to appraise the adequacy of such records as he did keep and which made it necessary to conduct an expensive and painstaking investigation to arrive at an agreed estimate of his tax liability for the years in question; at no point during the agents' original investigation can it be said that taxpayer was cooperative. From the outset, it can be fairly said that this record spells out a consistent course of action taken by the

taxpayer to willfully and knowingly evade the payment of any tax whatsoever.

As we have pointed out above, for purposes of assessing civil additions to tax under Section 293(b), there is no valid basis for invoking criminal standards of proof and differentiating a taxpayer's acts of commission or of willful omission as affirmative or passive, so long as the willfully intended result is the same—viz., the concealment from the taxing authorities of taxes rightfully due and owing. *Acker v. Commissioner, supra.*

In this connection, for purposes of assessment of the civil addition to tax, the only difference between complete concealment of all income received—such as was here the case—and partial concealment of income received, by filing a return and willfully omitting part of one's taxable income, is provided for in the statute by measuring the civil assessment of additional tax by the amount of the resulting deficiency. In other words, under Section 293(b), a complete willful failure to file and pay will produce a higher additional assessment than will result in the case of a willful partial concealment. In the circumstances here before the Court, the critical statutory test for determining that the deficiencies were due to fraud with intent to evade tax is met by proof that the failure to file was consistent, extending over a number of years, with taxable income in a substantial amount not being reported. This civil test for applicability of Section 293(b) was succinctly stated by Judge Staley of the Third Circuit in

*Schwarzkoft v. Commissioner*, decided July 10, 1957 (57-2 U.S.T.C., par. 9816), as follows:

The burden of proving fraud is, of course, upon respondent. Section 1112 of the Internal Revenue Code of 1939, 26 U.S.C. 1952 ed., § 1112. Petitioner contends that respondent failed to sustain his burden. This point shall not long detain us. Even if this case were devoid of the usual indicia of fraud, the consistent failure to report substantial amounts of income over a number of years, standing alone, is effective evidence of fraudulent intent.

In discussing *Spies v. United States*, *supra*, we pointed out our belief that the Eighth Circuit majority erred in *First Trust & Savings Bank v. United States*, *supra*, in applying the criminal attempt test of Section 145 (b) to Section 293 (b), which provides for only a civil addition to tax. We have already demonstrated the inapplicability of the *Spies* rationale to the instant case. Our final contention rests on the proposition that, in any event, the *First Trust & Savings Bank* case is clearly distinguishable from the instant case on its facts. This is clear, beyond question.

In the *First Trust & Savings Bank* case, the taxpayer, Mr. Kraftmeyer, was an Iowa farmer who attained the age of 70 without ever having filed a federal income tax return. His testimony at the trial was uncontradicted. The Eighth Circuit majority pointed out (206 F. 2d 97, 98):

He was in his 71st year when he gave his testimony in this case to the effect that he knew

nothing about bookkeeping and had never kept business records and no one ever told him that he had to file an income tax return. He heard of income tax prior to 1945, but thought that he "wasn't making any income" and that "he had no income". He figured that he was paying a general county and city tax and that based on what he had invested the investment wasn't making any particular return. He did not know that he owed any tax; did not know how to figure it out or how to go about it. He never had any fraudulent intent to evade taxes.

In addition, when Mr. Kraftmeyer was called in by the Revenue Agent pursuant to the investigation, the Eighth Circuit majority pointed out (pp. 98-99) that he employed an attorney and cooperated with the investigating officers in developing a full showing of all of his financial transactions throughout the period under review. At the trial, the revenue agent who made the investigation testified (p. 99) "he made no effort to conceal."



CONCLUSION

For the reasons given above, the judgment of the District Court should be affirmed.

Respectfully submitted,

JOHN N. STULL,  
*Acting Assistant Attorney  
General.*

LEE A. JACKSON,  
DAVIS W. MORTON,  
*Attorneys,  
Department of Justice,  
Washintgon 25, D. C.*

CLARENCE E. LUCKEY,  
*United States Attorney.*

AUGUST, 1957.

## APPENDIX

Internal Revenue Code of 1939:

## SEC. 291. FAILURE TO FILE RETURN.

(a) [as amended by Sec. 172(f) (4), Revenue Act of 1942, c. 619, 56 Stat. 798] In case of any failure to make and file return required by this chapter, within the time prescribed by law or prescribed by the Commissioner in pursuance of law, unless it is shown that such failure is due to reasonable cause and not due to willful neglect, there shall be added to the law: 5 per centum if the failure is for not more than thirty days with an additional 5 per centum for each additional thirty days or fraction thereof during which such failure continues, not exceeding 25 per centum in the aggregate. The amount so added to any tax shall be collected at the same time and in the same manner and as a part of the tax unless the tax has been paid before the discovery of the neglect, in which case the amount so added shall be collected in the same manner as the tax. The amount added to the tax under this section shall be in lieu of the 25 per centum addition to the tax provided in section 3612(d) (1).

\* \* \* \*

(26 U.S.C. 1952 ed., Sec. 291.)

## SEC. 293. ADDITIONS TO THE TAX IN CASE OF DEFICIENCY.

\* \* \* \*

(b) *Fraud*.—If any part of any deficiency is due to fraud with intent to evade tax, then 50 per centum of the total amount of the deficiency (in addition to such deficiency) shall be so assessed, collected, and paid, in lieu of the 50 per centum addition to the tax provided in section 3612(d) (2).

\* \* \* \*

(26 U.S.C. 1952 ed., Sec. 293.)

Sections 291 and 293(b) of the Revenue Act of 1936, c. 690, 49 Stat. 1648, and the Revenue Act of 1938, c. 289, 52 Stat. 447, are substantially the same as the sections set out above.



**United States**  
**COURT OF APPEALS**  
**for the Ninth Circuit**

---

GRACE M. POWELL, Executrix of the Estate of O. E.  
POWELL, Deceased,

*Appellant,*

vs.

RALPH C. GRANQUIST, District Director of Internal  
Revenue,

*Appellee.*

---

**REPLY BRIEF FOR THE APPELLANT**

---

*On Appeal from the Judgment of the United States  
District Court for the District of Oregon*

---

HUMPHREYS & JONES,  
ARTHUR D. JONES,  
904 Yeon Building,  
Portland 4, Oregon,

FREDERICK A. JAHNKE,  
815 Executive Building,  
Portland 4, Oregon,

*Attorneys for Appellant.*

FILED

AUG 21 1957

PAUL P O'BRIEN, CLERK



## SUBJECT INDEX

	Page
Re: Appellee's Distinction Between This Case and the First Trust and Savings Bank Case .....	1
Re: Appellee's Argument on the Applicability of Section 293(b) Internal Revenue Code of 1939 (A 50% Civil Addition to Tax) Rather than Section 291(a) Internal Revenue Code of 1939 (A 5% to 25% Civil Addition to Tax for Failure to File a Return) .....	7
Conclusion .....	11

## TABLE OF CASES

DeGanay vs. Lederer, 250 U.S. 276.....	9
First Trust and Savings Bank vs. U. S., 206 Fed. 2d 97.....	1, 3
Gould vs. Gould, 245 U.S. 151.....	9
Helvering vs. Mitchell, 303 U.S. 391.....	7
Kraftmeyer vs. U. S. 52-1 USTC Par. 9328.....	2, 3
McFeely vs. Commissioner, 296 U.S. 102.....	9
New Colonial Ice Co. vs. Helvering, 292 U.S. 435.....	9
Ohlinger vs. United States, 219 Fed. 2d 310 (C.A. 9th) .....	4
Schwarzkoft vs. Commissioner, 57-2 USTC Par. 9316 .....	11
Semietanka vs. First Trust and Savings Bank, 257 U.S. 602 .....	9





United States  
**COURT OF APPEALS**  
for the Ninth Circuit

---

GRACE M. POWELL, Executrix of the Estate of O. E.  
POWELL, Deceased,

*Appellant,*

vs.

RALPH C. GRANQUIST, District Director of Internal  
Revenue,

*Appellee.*

---

**REPLY BRIEF FOR THE APPELLANT**

---

*On Appeal from the Judgment of the United States  
District Court for the District of Oregon*

---

**Re: Appellee's Distinction Between This Case  
and the First Trust and Savings Bank Case.**

Throughout Appellee's brief, the assertion is made that the above quoted case, *First Trust and Savings Bank vs. United States*, 206 Fed. 2d 97, is distinguishable on its facts from this case. Appellant has cited this case for the controlling authority in support of her assertion that the decision of the lower court should be reversed. An analysis of the facts of that case would

indicate that the facts of that case are parallel to the facts of the present case. Drawing a parallel between the facts of that case and this case, one finds as follows: (Bearing in mind that some of these facts must be gleaned from the District Court opinion.) *Kraftmeyer vs. U. S.*, 52-1 USTC Par. 9328, decided May 13, 1952. Kraftmeyer's tax for the identical nine years in question, 1937 through 1945, inclusive, \$76,738.18 (Dist. Ct. opinion); Powell's taxable income, 1937 through 1945, inclusive, \$25,760.74. Both taxpayers pleaded guilty to a criminal charge under 26 U.S.C.A. Sec 145(a) for wilfully failing to make the income tax return required of him. Both failed to keep a formal set of books and records and the Internal Revenue Agent who investigated their cases was forced to look to subsidiary records to redetermine the taxable income. In neither case was there any evidence of the destruction of records, the alteration of any records or false entries made in any books. Both Mr. Kraftmeyer and Mr. Powell were successful in their business endeavors although Mr. Kraftmeyer made about three times as much net taxable income during the years in question as Mr. Powell. Some facts that make the Powell case much stronger than the Kraftmeyer case are that Kraftmeyer specifically made false statements to the examining agent. As the District Court observed:

“Plaintiff was the only witness in his behalf. The Defendant produced two witnesses, one, Deputy Collector Ryan in Davenport, who first interviewed the Plaintiff in late 1946. He testified that when Plaintiff came in response to his call, he stated that he could not find his retained copies of income

tax returns, that he had lacked time to search for them and that they were in his safe deposit box. The witness stated that twice during the interview Plaintiff had stated he made returns but did not have time to bring them with him. . . .”

The Court in the District Court further observed:

“When first confronted he made false statements to the agent before admitting his dereliction. Plaintiff’s entire course of conduct reveals what the Court must find in the light of the whole record to have been not only an omission but an *intentional evasion of his duty to make an annual return of income and pay tax thereon*. After seeing and hearing the witness the Court accepts as true the agent’s statement of Plaintiff’s misrepresentation that he had filed returns and rejects Plaintiff’s denial of the truth of that statement. . . .”

On Page 17 of Appellee’s brief argument is made that the failure to file income tax returns over a sustained period of time would be the equivalent of fraud. In the *First Trust and Savings Bank* case, supra, (District Court opinion) the taxpayer in that case failed to file returns for the identical period that Mr. Powell failed to file returns.

To fully appreciate the full significance of the *First Trust and Savings Bank* case, supra, one should read the opinion of the Court of Appeals for the Eighth Circuit together with the District Court opinion. When one does that, additional facts are adduced that make the case before this Court appear much more favorable than the *First Trust and Savings Bank* case, supra.

The Appellee made much of the fact that Mr. Powell seemed antagonistic toward the internal revenue agents

who investigated him. However, we are concerned with the acts that took place during the taxable years 1937 to 1945, inclusive, and not with the acts during the course of investigation subsequent to these years. Our inquiry must be directed to acts that transpired during those years. On page 11 of Appellee's brief, the Appellee quoted from the opinion of the District Court Par. R. 81:

“There is no evidence in the record of alteration or concealment of bank statements, cancelled checks or real estate contracts by the taxpayer. Mr. Powell said he did not have records and there is no evidence of these having been destroyed or falsely made. However, there was no need for him to make false records or destroy records in contemplation of an investigation by the Internal Revenue Service, when at the time the taxpayer wasn't making or filing any income tax return. The same is true of concealment of assets and other ‘badges of fraud’ to which reference has been made. *The mere fact that these acts were not apparent at the time he was failing to make returns does not mean they didn't exist.*”

The italicized portion of the above quote clearly demonstrates that the Court bottomed its finding on inferences and not on “clear and convincing evidence.” There is no question that the government must prove fraud by clear and convincing evidence, *Ohlinger vs. United States*, 219 Fed. 2d 310 (C.A. 9th), a thesis which the Appellee readily admits in his brief (p. 23). However, such inferences are incompatible with the testimony of the Appellee's own witnesses on cross-examination. Harold Parsons, Special Agent, Internal Revenue Service, testified (R. 112):

“Q. Mr. Parsons, did you ever find any evidence of Mr. Powell having destroyed records?

A. No.

Q. Did you find any evidence of false records?

A. No.”

Appellee’s witness, Daniel S. Forsberg, Internal Revenue Agent, testified (R. 122):

“Q. Now, in your report of your investigation did you find that Mr. Powell had destroyed any records?

A. He said he kept no records.

Q. What I was referring to was cancelled checks and normal subsidiary records that you find in the taxpayer’s possession.

A. The cancelled checks, as I stated before, were all there, and the bank statements except for the first half of 1937, when the checks were missing.

Q. Did you find any evidence of any attempt on his part to alter any of these records?

A. There was no alteration of any of the bank statements or cancelled checks that I examined; no sir.”

Mr. Forsberg further testified (R. 123):

“Q. Were there any alterations on these real estate contracts?

A. The contracts that were given to us, that we requested, seemed to be in good order.

Q. So in your investigation you found no destruction of records, and no alterations of subsidiary records and these real estate contracts which you stated.

A. The contracts were in order that we saw. The bank statements and cancelled checks except for the checks for 1937—the first half—were in order, there was no destruction of those and nothing where I could see that they had been tampered with in any way.”

Mr. Milkes, witness for the Appellee, testified as follows (R. 156-157):

“Q. Mr. Milkes, in your work in accounting you are primarily looking for—one of your primary purposes is looking for discrepancies in records, is that correct?”

A. Yes, I would say that is correct, not looking for fraud or anything like that but looking for errors in recording the information for accounting purposes—for tax purposes and I might say, incidentally, for fraud also.

Q. It is your nature to observe in going through data for accounting, any irregularities such as alterations?

A. Yes.

Q. And it is your practice to observe any destruction of records or subsidiary records?

A. Well, sure, if there is any evidence of it.

Q. Then, chances are, in the course of your examination, if there had been any alterations or destruction of these records it would have come to your attention?

A. Yes, sir.

Q. Were the subsidiary records that were made available to you for the taxable years 1937 to 1945 adequate to fairly reconstruct the income and expenditures of Mr. Ora E. Powell?

A. Substantially so, yes.

Mr. Jones: Your witness.

Mr. Andrews: No further questions.

Mr. Jones: I would like to call Mr. Lee Powell to the stand.”

**Re: Appellee's Argument on the Applicability of Section 293(b) Internal Revenue Code of 1939 (A 50% Civil Addition to Tax) Rather Than Section 291(a) Internal Revenue Code of 1939 (A 5% to 25% Civil Addition to Tax for Failure to File a Return).**

On page 14 of the Appellee's brief, argument is made that in all cases the wilful failure to pay tax known to be owing requires the invoking of Section 293(b), (the 50% civil addition to tax) instead of Section 291(a), (the 5% to 25% civil addition to the tax) for failure to file a return. There is no question in this case that the lesser penalty has been assessed and collected and no contention is being made that the civil penalty should be returned to the taxpayer. The taxpayer's contention is that the 50% civil addition is inapplicable because no overt of commission has been proved by the Appellee by *clear and convincing evidence*. Appellee's argument is that the wilful failure to file a tax return results the lesser penalty, but the wilful failure to pay the tax in addition to the wilful failure to file a return the greater penalty as well as the lesser penalty attaches. The Appellee correctly argues that the civil penalties is a remedial section "provided primarily as a safeguard for the protection of revenue and to reimburse the heavy expense of investigation and loss resulting from the taxpayer's fraud." Citing *Helvering vs. Mitchell*, 303 U.S. 391, 401. The statutory language of Section 291(a) is as follows:

"In case of any failure to make and file returns required by this chapter, within the time prescribed by law or prescribed by the commissioner in pur-

suance of law, unless it is shown that such failure is due to a reasonable cause and not due to wilful neglect there shall be added to the tax: 5% if failure is for not more than 30 days with an additional 5% for each additional 30 days or fraction thereof during which such failure continues, not exceeding 25% in the aggregate.”

The plain implication of the language contained in this penalty provision is there would also be a non-payment of tax because before the penalty would produce revenue, there must be a tax due and owing.

Section 293(b) (50% addition to tax) specifically reads:

“Fraud.—If any part of the deficiency is due to fraud with intent to evade tax, then 50% of the total amount of the deficiency if in addition to such deficiency shall be assessed, collected and paid in lieu of the 50% addition to the tax provided in Section 3612(d) 2.”

The Appellee is attempting to add the language “wilful failure to pay tax known to be owing” to the above quoted section. If Congress had intended that result they would have written that section in the same fashion they wrote such sections as Section 145(a), Internal Revenue Code of 1939, which provides specifically

“ . . . any person required under this chapter *to pay* an estimated tax or tax . . . ”

and

“ . . . who wilfully fails *to pay such estimated tax or tax . . .* ”

Section 294, Internal Revenue Code, is headed by the following caption:

“*Additions to the tax in case of nonpayment.*”



Since no 50% penalty is contained in this section, it would seem that the statutory construction as contended by Appellant would follow. In case of doubt, taxing statutes are construed most strongly against the government and in favor of the citizen. *Gould vs. Gould*, 245 U.S. 151; *Semietanka vs. First Trust and Savings Bank*, 257 U.S. 602; *McFeely vs. Commissioner*, 296 U.S. 102.

In *New Colonial Ice Co. vs. Helvering*, 292 U.S. 435, the Supreme Court held that since every deduction from gross income is a matter of legislative grace, any particular deduction is allowable only if there is a clear provision therefor and hence a taxpayer seeking a deduction must be able to point to an applicable statute and show that he comes within its terms. The reverse of this thesis should be true, particularly more so when a penalty is being enacted, i.e., if the government is to exact a penalty from the taxpayer it must show a positive provision for the penalty and show that it comes within its terms. Since the penalty that has been exacted here was for fraud, the government must go further and show by clear and convincing evidence that it comes within the statute.

The Appellee seems to be putting a strained construction on the word "fraud" as used in Section 293(b) of the Internal Revenue Code. As the Supreme Court has said in *DeGanay vs. Lederer*, 250 U.S. 276:

" . . . statutory words are presumed to be used in their ordinary and usual sense, and with the meaning commonly attributable to them."

When "fraud" is used in its common ordinary sense it

contemplates affirmative action on the part of the taxpayer and not passive neglect. Throughout Appellee's brief he makes reference to the continued failure to file returns over a period of time as elevating this omission from the lesser penalty to the greater penalty, i.e., from Section 291(a) which specifically provides for the wilful failure to file tax returns to Section 293(b), the greater penalty fraud. It would seem to be a strange construction, indeed, to say that where the statute clearly defines an offense, failure to file returns, Section 291(a), that two of these clearly defined omissions would place it in another section of the Internal Revenue Code.

On page 23 of Appellee's brief the following statement is made:

"A taxpayer with sufficient taxable income to require the filing of returns might have sufficient deductions, if he filed the return, to avoid payment of any tax whatsoever. If he wilfully omitted to file such a return he would be technically in violation of Section 291(a), or he could be convicted of a misdemeanor under Section 145(a), since the requirements of that penalty statute are similarly satisfied, but where a taxpayer wilfully omits to file a return and the omission results in substantial taxable income never being brought to the attention of the taxing authorities, as a consideration separate and apart from the Section 291(a) violation, the omission or concealment produces the direct result that tax has been evaded, with the wilful purpose to omit the filing of the return serving to warrant the inference of evasion."

This statement of the Appellee would make Section 291(a) meaningless in our taxing framework. It must be pointed out that Section 291(a) is placed in the In-

ternal Revenue Code as a producer of revenue for the purpose of compensating the government, which argument has been made in Appellee's brief and agreed as being a correct interpretation of the law by Appellant in this reply brief. But yet, Appellee would argue that if the taxpayer failed to file a return and no tax is owing, he would be in violation of Section 291(a). This interpretation would make Section 291(a) meaningless, as to collect a penalty there must be a tax due and owing upon which to attach the penalty. As his example states, the taxpayer would have sufficient deductions to avoid any payment of tax. There would be no revenue produced as the penalty attaches to the tax due and owing. In any event there would be no tax due or owing, whether he filed a return or whether he failed to file a return, and the invocation of Section 291(a) would not produce a penny's worth of revenue for the government to compensate them for their efforts in detecting the omission.

The case of *Schwarzkoft vs. Commissioner*, decided July 10, 1957 (57-2 U.S.T.C., Par. 9816) is clearly distinguishable from the case at bar because there the taxpayer filed tax returns and failed to report substantial amounts of income over a number of years.

### **Conclusion**

The Appellee summarizes his argument, Appellee's brief, pages 25 through 34.

1. Taxpayer was aware of his duty to file income tax returns and yet he failed to file.

2. Appellee argues that taxpayer was aware, throughout the period under review, that he had taxable income which he was not reporting. He bottoms this fact on the fact that Carl T. Armstrong, the government's witness, so advised him at the beginning of the period in question. (It is impossible for any business man to forecast whether he will have taxable income in a taxable year at the beginning of the fiscal period.)

3. The awareness on the part of the taxpayer of his responsibility to file federal returns and his failure to file was wilful.

4. The taxpayer did not keep books and records. All of these acts as alleged by Appellee in his brief are merely acts of "wilful neglect" the exact penalty prescribed by Section 291(a) 25% penalty which is not being controverted here and which has been collected by the Appellee.

For the reasons stated above the decision of the District Court for the District of Oregon should be reversed and judgment entered for the Petitioner allowing a refund of \$12,880.39 plus interest from the date of payment.

Respectfully submitted,

FREDERICK A. JAHNKE,

815 Executive Building,  
Portland 4, Oregon,

Of Attorneys for Appellant.













